

# SOFT JAW

SOFT JAW  
软爪 / 生爪 / 소프트 조오

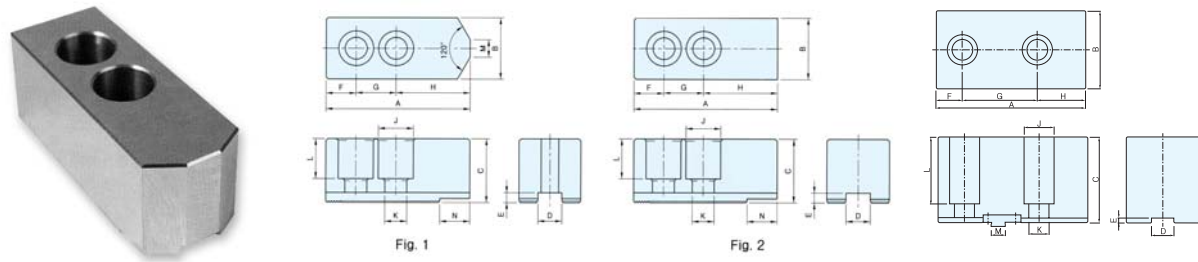

## Dimension / 尺寸 / 寸法表 / 치수표

Type	Fig	Serration	A	B	C	D	E	F	G	H	J	K	L	M	N	Matching Chuck 적용척
SJ-04T1	1	1.5X60°	47.5	25	25	11	4	9.5	16	22	14	9/82	16	4	5.5	27M/37M-4.5
SJ-04T2	1	1.5X60°	54	25	25	10	5	10	14	30	13.5	9	14	8	3	1MA-4
SJ-05T1	1	1.5X60°	54	23	25	10	4	11.5	14	28	13.5	8.5	16.5	5	-	CAH-5
SJ-05A1	2	1.5X60°	58.5	25	25	10	5	8	19	31.5	14	9	14	-	-	1MA-5
SJ-06T1	1	1.5X60°	72	31	31.5	12	5	15	20	37	17.5	11	19.5	12	15	CAH/CAS/CGH-6
SJ-06A1	2	1.5X60°	66	35	35	12	5	14.5	20	31.5	17.5	11	22	-	-	27M/37M-6
SJ-08T1	1	1.5X60°	95	37	37.5	14	5	20	25	50	20	14	22.5	12	20	CAH/CAS/CGH-8
SJ-08A1	2	1.5X60°	85.5	40	40	16	5	20	25	40.5	20	13.5	26	-	-	27M/37M-8
SJ-10T1	1	1.5X60°	110	44	44.5	16	5	30	30	50	20	14	28.5	15	20	CAH/CAS/CGH-10
SJ-10T2	1	1.5X60°	108	45	45	18	5	24	30	54	23	16	30	8	-	27M/37M-10
SJ-12T1	2	1.5X60°	129	49	49	18	6	39	30	60	23	16	31	-	-	CAS/1MA12
SJ-12A1	2	1.5X60°	111	49	49.5	21	5	21	30	60	25	17	31.5	-	-	CAH-12
SJ-12A3	2	1.5X60°	111	50	60	21	5	25	35	51	26	18	42	-	-	27M/37M-12
SJ-15A1	2	1.5X60°	165	59	59.5	22	8	47	43	75	32	22	36	-	-	CAH-15,18
SJ-15A2	2	3.0X60°	156	65	70	26	8	34	50	72	32	22	50	-	-	1MA-15,18,21
SJ-15A3	2	1.5X60°	135	50	59	25.5	5	26	43	66	32	21	39	-	-	CAS-15,18
SJ-21A1	2	3.0X60°	180	59	59.5	25	9.5	40	60	80	32	22	36	-	-	CAH/CAS-21,24
SJ-21A2	2	3.0X60°	180	65	70	26	8	34	50	96	32	22	50	-	-	1MA-21,24
SJ-32A1	3	-	165	75	83	12.7	12.5	21.9	76.2	66.9	32	22	54	19.03	-	CAS-32,32HC
SJ-40A1	3	-	200	98	110	30	6	35	100	65	40	27	86	19.03	-	CAS-40, 50
SJ-40A2	3	-	270	110	110	30	8.5	48.8	2-76.2	68.8	40	27	85	19.03	-	CAS-40HC, 50HC

# HARD JAW

HARD JAW  
硬爪 / 硬爪 / 하드 조오

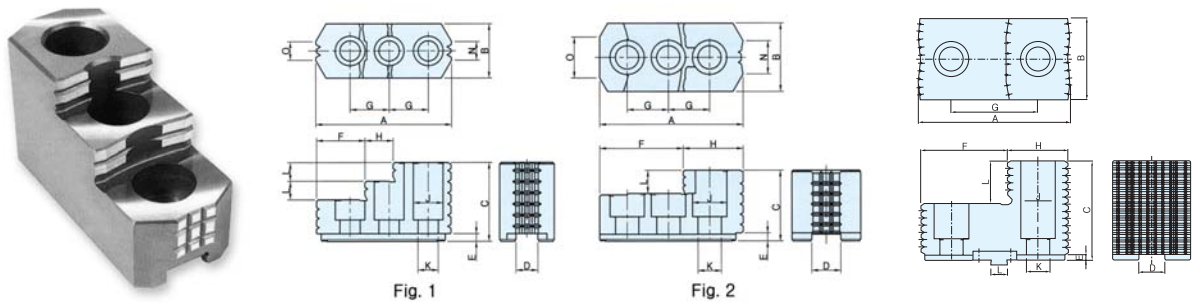

## Dimension / 尺寸 / 寸法表 / 치수표

Type	Fig	Serration	A	B	C	D	E	F	G	H	J	K	L	N	O	Matching Chuck 적용척
HJ-04A1	2	1.5X60°	54.3	28	30	11	5	23.7	16	30.6	14	9	8	-	-	27M/37M-4.5
HJ-06T1	1	1.5X60°	75.5	31	41	12	5	30	20	12	17.5	11	10	10	15	CAH/CAS/1MA-6
HJ-06A1	2	1.5X60°	65.8	35	35	12	5	32.7	20	33.1	17.5	11	11	9	13	27M-6/37M-6
HJ-08T1	1	1.5X60°	87	39	51	14	5	27	25	22	19	13	12	12	12	CAH/CGH/CAS-8
HJ-08A2	2	1.5X60°	83.1	40	40	16	5	42.8	25	40.3	20	14	13	12	11	27M-8/37M-8
HJ-10T1	1	1.5X60°	101	40	54	16	5	43	30	17	19	13	13	15	15	CAH/CGH/CAS-10
HJ-10A1	2	1.5X60°	98.3	45	45	18	5	54.3	30	44	23	16	15	17	24	27M/37M-10
HJ-12A1	2	1.5X60°	105.8	50	52	21	5	60.5	30	45.3	25	17	17	30	30	CAH-12
HJ-12A2	2	1.5X60°	114.2	50	55	21	5	68.1	35	46.1	26	18	20	18	18	27M/37M-12
HJ-12T1	1	1.5X60°	104.4	50	62	18	6	29.6	30	30.3	23	16	15	25	25	CAS/1MA-12
HJ-15T1	1	1.5X60°	159.2	62	86	22	8	66	43	35	32	21	20	40	40	CAH-15,18
HJ-15A1	2	3.0X60°	153.5	65	75	26	8	83	50	70.5	32	22	30	44	44	1MA-15,18,21
HJ-15A3	1	1.5X60°	149	62	86	25.5	5	69	43	27	32	21	20	43	38	CAS-15,18
HJ-21B1	2	3.0X60°	159.5	80	90	25	12	103.48	50	56.2	32	22	40	55	-	CAH/CAS-21,24
HJ-32A1	3	-	145	70	75	12.7	5	66	76.2	79	32	22	32	19.03	-	CAS-32,32HC
HJ-40A1	3	-	170	90	110	30	6	110	100	70	40	27	47	19.03	-	CAS-40,50
HJ-40A2	3	-	222.5	80	117	30	8.5	133	114.3	89.5	40	27	55	19.03	-	CAS-40HC,50HC

# ADAPTER

ADAPTER  
法兰 /アダプタ/아답터

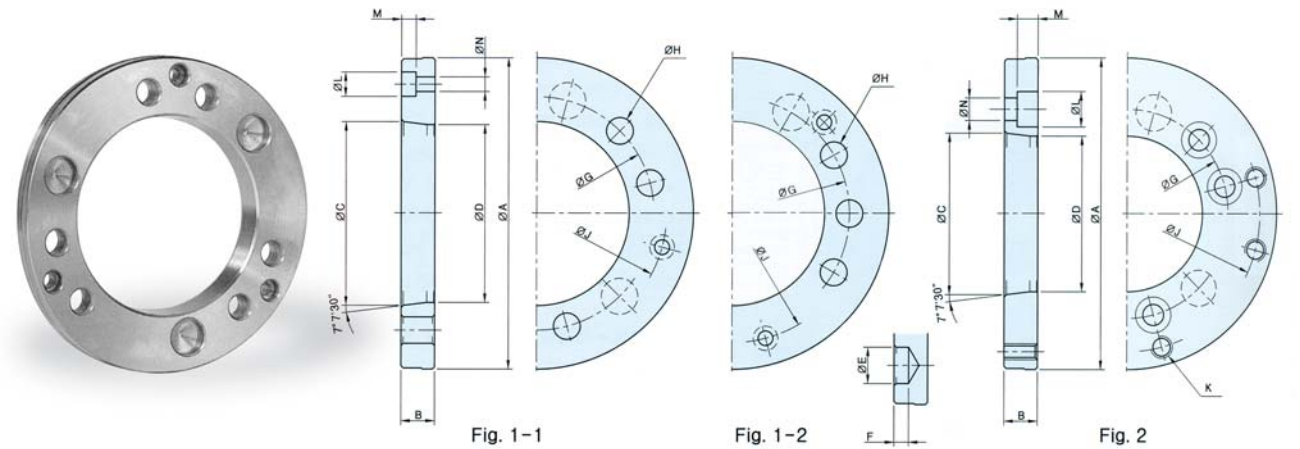

## Outward Drawing / 外形图 / 外形图 / 외형도

Model형식	Item항목	spindle nose	Fig	A	B	C	D	E	F	G	H	J	K	L	M	N	Matching Chuck 적용척
AD-06A05		A2-5	1-1	140	15	82.563	79.7	16.3	6.5	104.78	12	116	-	11	6.5	6.6	CAH, CAS
AD-08A05		A2-5	2	170	25	82.563	79.7	16.3	6.5	104.78	-	133.35	M12	17.5	11.5	11	CAH, CAS
AD-08A06		A2-6	1-1	170	17	106.375	103	19.45	6.5	133.35	13.5	150	-	11	6.5	6.6	CAH, CAS
AD-10A06 AD-12A06		A2-6	2	220	25	106.375	103	19.45	6.5	133.35	-	171.45	M16	20	13.5	14	CAH, CAS
AD-10A08 AD-12A08		A2-8	1-1	220	18	139.719	136	24.2	8	171.45	18	190	-	14	10	9	CAH, CAS
AD-15A11		A2-11	1-1	300	22	196.87	192.1	29.36	10	235	21	260	-	17	11	11	CAH
ADT-06A05		A2-5	1-2	140	15	82.563	79.7	16.3	6.5	104.78	12	116	-	11	6.5	6.6	CAHT, CAST
ADT-08A06		A2-6	1-2	170	17	106.375	103	19.45	6.5	133.35	13.5	150	-	11	6.5	6.6	CAHT, CAST
ADT-10A08		A2-8	1-2	220	18	139.719	136	24.2	8	171.45	18	190	-	14	10	9	CAHT, CAST

# Short taper Spindle Nose

Short taper Spindle Nose  
主轴端规格 / 主轴テーパ规格 / 주축단 규격

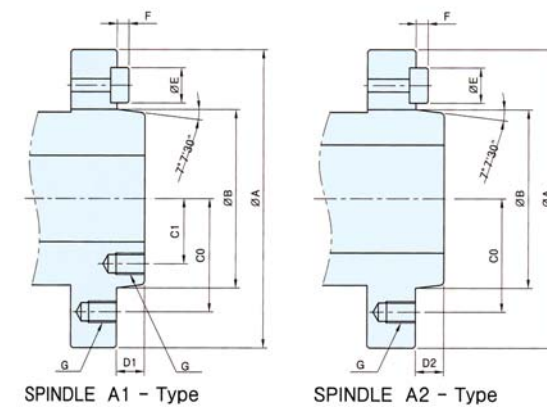

## Dimension / 尺寸 / 寸法表 / 치수표

spindle nose	A	B	C0	C1	A1-Type D1	A2-Type D2	E	F	G
3	92	53.975	35.3	-	-	11	-	-	M10
4	108	63.513	41.3	-	-	11	14.15	5	M10
5	133	82.563	52.4	30.95	14.29	13	15.9	5	M10
6	165	106.375	66.7	41.3	15.88	14	19.05	5	M12
8	210	139.719	85.7	55.55	17.46	16	23.8	6	M16
11	280	196.869	117.5	82.55	19.55	18	28.6	8	M20
15	380	285.77	165.1	123.8	20.64	19	34.9	8	M22

## Model Description / 型号说明 / 型式番号表示 / 형식번호 표시

**▶ Soft Jaw**  
**SJ** -        
 Chuck Size      Option  
 Shape A | Flat(각형)  
           B | Protrude(산형)

**▶ Hard Jaw**  
**HJ** -        
 Chuck Size      Option  
 Shape A | 2 Step(2단)  
           B | 3 Step(3단)

**▶ Adapter**  
**AD**  -       
 Chuck Size      Spindle Nose  
 Blank | Standard  
       T | 2-jaw type