

LOG

Special Grippers | Hole Gripper

Cost-efficient. Smoothly running. Reliable.

Hole Gripper LOG

Light gripper made of very resistant polyamide with closed diaphragm system

Field of Application

Particularly suitable for highly dynamic applications with a low workpiece weight, for handling of small components and plastic parts, as well as for sand core handling.



Advantages – Your benefits

Low weight allows high dynamics in the application

Closed membrane system and internal stop protect the expansion membrane against damage

Short delivery time for customized measurements

Long service life enables long-lasting economical use

Air supply via hose-free direct connection or screw connections for flexible pressure supply in all automated systems



Sizes
Quantity: 5



Weight
0.008 .. 0.44 kg



Clamping diameter
20 .. 99 mm



Workpiece weight
0.55 .. 12.83 kg



Functional Description

The membrane expands when pressure is applied, creating a synchronized movement of the gripping surfaces.

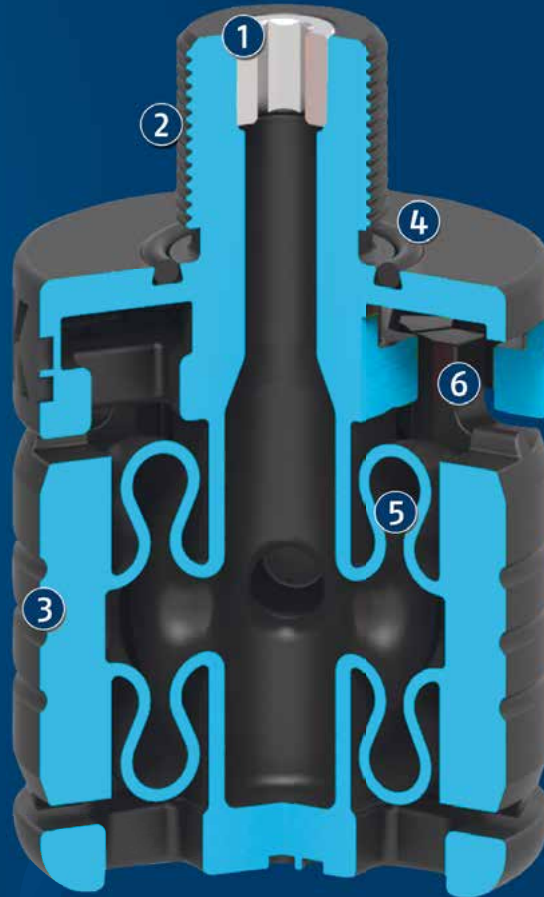

① Air connection thread

② Mounting threads

③ Gripping surface

④ O-ring seal

For hose-free air connection

⑤ Membrane

⑥ Internal stop/overload protection

General Notes about the Series

Operating principle: Membrane

Housing material: PA 12

Base jaw material: PA 12

Actuation: Pneumatic, with filtered compressed air as per ISO 8573-1:2010 [7:4:4]

Scope of delivery: Assembly instructions (operating manual with declaration of incorporation is available online)

Gripping force maintenance: Not possible

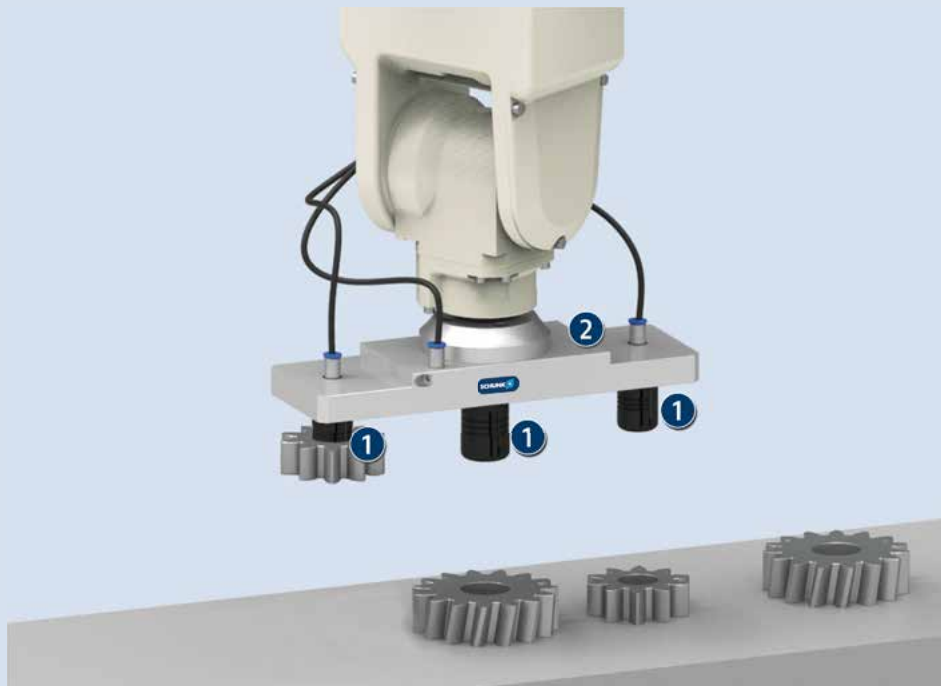

Application Example

Handling of gears with different diameters.

❶ Hole gripper LOG

❷ Customized adapter plate

SCHUNK offers more ...

The following components make the product LOG even more productive – the suitable addition for the highest functionality, flexibility, reliability, and process safety.



Universal gripper



Miniature swivel unit



Linear module



Compensation unit



Pressure maintenance valve



Manual change system

① Further information on these products can be found on the following product pages or at schunk.com. Please contact us: SCHUNK technical hotline +49-7133-103-2696

Options and special Information

Additional sizes and customized designs are available upon request



Gripping force I.D. gripping

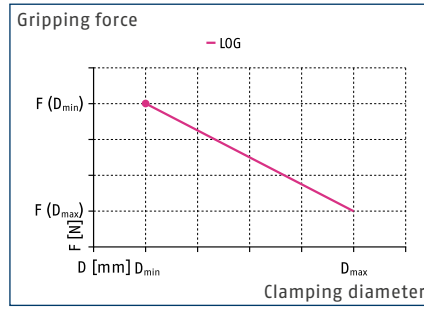

Creep properties

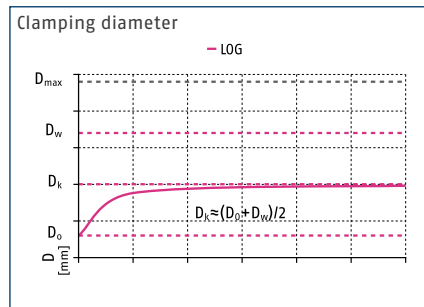

Dimensions and maximum loads

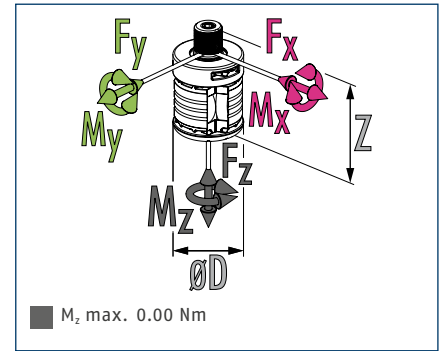

① The indicated moments and forces are static values and should not appear simultaneously.

Technical data

Description		LOG 20.0-M14x1.5-M5	LOG 40.0-M16x1-M5	LOG 60.0-M16x1-M5	LOG 80.0-M20x1,5-G1/8	LOG 99.0-M20x1.5-G1/8
ID		0398920	0398940	0398960	0398980	0398999
Mounting thread A		M14 x 1.5	M16 x 1	M16 x 1	M20 x 1.5	M20 x 1.5
Air connection thread B		M5	M5	M5	G1/8"	G1/8"
Min. workpiece diameter	[mm]	20	40	60	80	99
Max. workpiece diameter	[mm]	20.3	44.37	66.13	88.7	110.7
Opening force for $\varnothing D_{min}$	[N]	107.2	241.4	596.7	972.7	2516.7
Opening force for $\varnothing D_{max}$	[N]	27.3	66.7	190.5	433.3	1166.7
Weight	[kg]	0.008	0.034	0.108	0.238	0.44
Recommended workpiece weight	[kg]	0.55	1.23	3.04	4.96	12.83
Fluid consumption double stroke	[cm ³]	2.35	8.21	28.82	65.34	122.8
Max. operating pressure	[bar]	6	6	6	6	6
Nominal operating pressure	[bar]	6	6	6	6	6
Closing/opening time	[s]	0.05/0.05	0.08/0.08	0.14/0.14	0.22/0.22	0.44/0.44
Min./max. ambient temperature	[°C]	-40/80	-40/80	-40/80	-40/80	-40/80
Housing material		PA 12	PA 12	PA 12	PA 12	PA 12
Dimensions $\varnothing D \pm 0.2 \times Z$	[mm]	19.8 x 46	39.6 x 64	59.4 x 87.5	79.2 x 111	98.01 x 123.33
Moments M_x max./ M_y max.	[Nm]	1.50/1.50	2.00/2.00	2.00/2.00	2.50/2.50	2.50/2.50
Forces F_x max./ F_y max./ F_z max.	[N]	150.00/150.00/150.00	200.00/200.00/200.00	200.00/200.00/200.00	250.00/250.00/250.00	250.00/250.00/250.00

① The gripping force can be set directly by the operating pressure. At a lower pressure than the nominal operating pressure, the full stroke cannot be achieved.

The graduation of the individual sizes varies about 1 mm. Please consider that the size of the mounting thread A depends on the individual gripper size. (LOG 20–25: M14 x 1.5; LOG 26–63: M16 x 1; LOG 64–99: M20 x 1.5).

Information on further gripper sizes are available online.

More detailed, up-to-date information on the SCHUNK product including drawings, CAD data, and operating manuals are available online at: schunk.com/log