

# KINTEK®

**TOOLHOLDERS FOR CNC LATHES (BMT, BOLT-ON, VDI DIN69880)**  
PORTAUTENSILI PER TORNI CNC (BMT, BOLT-ON, VDI DIN69880)



**TOOLHOLDERS FOR CNC LATHES**  
**(BMT, BOLT-ON, VDI DIN69880)**



PORTAUTENSILI PER TORNII CNC  
(BMT, BOLT-ON, VDI DIN69880)



CNC-DREHEMASCHINEN  
(BMT, BOLT-ON, VDI DIN69880)



PORTE-OUTILS POUR TOURS CNC  
(BMT, BOLT-ON, VDI DIN69880)



РЕЗЦЕДЕРЖАТЕЛИ ДЛЯ  
ТОКАРНЫХ СТАНКОВ С ЧПУ  
(BMT, BOLT-ON, VDI DIN69880)



数控车床刀柄  
BMT, BOLT-ON, VDI DIN69880



SPECIAL TOOLHOLDERS    PORTAUTENSILI SPECIALI  
 SONDER-WERKZEUGHALTER    PORTEOUTILS SPECIAUX  
 СПЕЦИАЛЬНЫЕ РЕЗЦЕДЕРЖАТЕЛИ    专用刀柄

**BIGLIA TOOLHOLDERS**

PORTAUTENSILI BIGLIA

Pag. 325

**DMG MORI TOOLHOLDERS**

PORTAUTENSILI DMG MORI

Pag. 326-340

**OKUMA TOOLHOLDERS**

PORTAUTENSILI OKUMA

Pag. 341-349

**NAKAMURA TOME TOOLHOLDERS**

PORTAUTENSILI NAKAMURA

Pag. 350-353

**DOOSAN PUMA TOOLHOLDERS - BMT 45 /55/65/75**

PORTAUTENSILI DEWOO PUMA

Pag. 354-360

**MAZAK TOOLHOLDERS**

PORTAUTENSILI MAZAK

Pag. 361-363

**HAAS TOOLHOLDERS**

PORTAUTENSILI HAAS

Pag. 364-365

**WFL TOOLHOLDERS**

PORTAUTENSILI WFL

Pag. 366

**GOODWAY TOOLHOLDERS**

PORTAUTENSILI GOODWAY

Pag. 367

## BIGLIA

B301/445/470/501(Y-S)  
510/545/550/565/650/658  
1200/446/465/745  
765-B750/1250 16 ST.

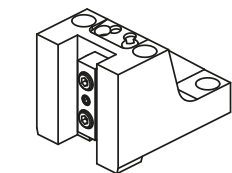

128-41524  
128-41525 (25x25 mm)

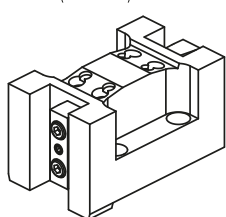

128-41527

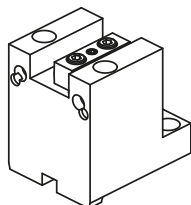

128-31515

Face and O.D. cutting holder

Face and O.D. cutting holder

Face and O.D. cutting holder

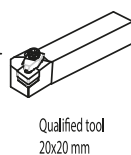

Qualified tool  
20x20 mm

Face and O.D. cutting holder

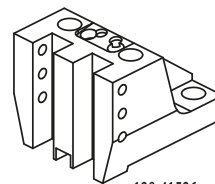

128-41526

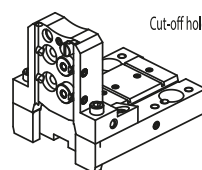

Cut-off holder



Cut-off tool  
26 mm  
32 mm

128-11566 (26 mm)  
128-11567 (32 mm)

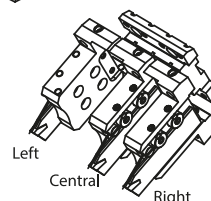

Left  
Central  
Right

### ACCESSORIES

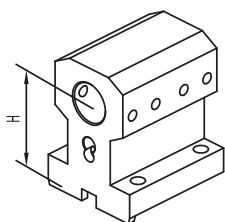

128-21538 H=80  
128-21540 H=100

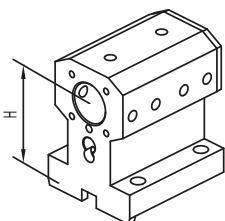

128-21539 H=80  
128-21541 H=100

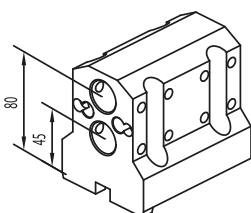

128-21542

Toolholder for boring bar

Ø32 mm

Combi toolholder for boring bar and insert drill

Ø32 mm

Toolholder for boring bar

2xØ25 mm

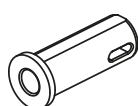

Drill socket  
114-33208 <MT1>  
114-33209 <MT2>

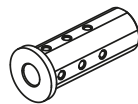

Boring bar sleeve  
115-63260 (Ø8 mm)  
115-63261 (Ø10 mm)  
115-63211 (Ø12 mm)  
115-63212 (Ø16 mm)  
115-63213 (Ø20 mm)

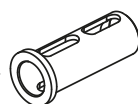

Boring bar sleeve  
115-63214 (Ø25 mm)

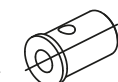

Throw-away drill socket  
165-63325 (Ø16 mm)  
165-63326 (Ø20 mm)  
165-63327 (Ø25 mm)



Protection cover  
137-00244

### CONNECTION

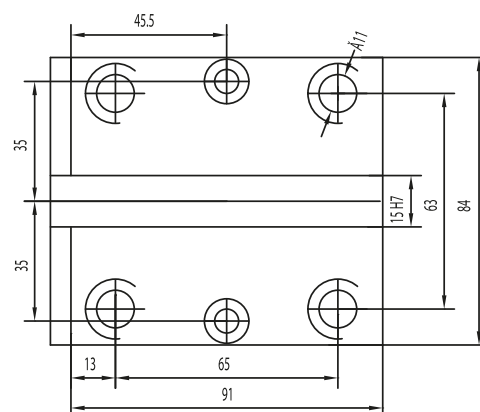



## DMG MORI (VDI30)

CTX 210/310/410 V3/V1  
 CTX 320/420 V3  
 CTX Alpha 300/500 V3  
 CTX Beta 500/800/1250 V3 (option)  
 CTV 160

### AXIAL TURRET

Face and O.D. cutting holder  
 B1-30x20x40

Face and O.D. cutting holder overhead  
 B3-30x20x40

Face and O.D. cutting holder  
 B5-30x20x40

Face and O.D. cutting holder overhead  
 B7-30x20x40

Cut-off holder  
 26 mm  
 AR3026

Bar puller  
 KH1-30

VDI damped, adjustable, stop bar  
 MW-3042-AM

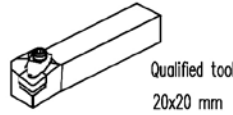
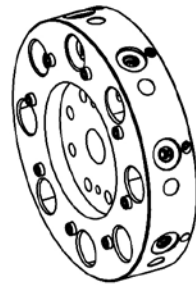

### ACCESSORIES



Boring bar sleeve  $\varnothing 25$  mm

- 115-62574 ( $\varnothing 8$  mm)
- 115-62575 ( $\varnothing 10$  mm)
- 115-62576 ( $\varnothing 12$  mm)
- 115-62577 ( $\varnothing 16$  mm)
- 115-62578 ( $\varnothing 20$  mm)

Boring bar sleeve  $\varnothing 32$  mm

- 165-63223 ( $\varnothing 8$  mm)
- 165-63224 ( $\varnothing 10$  mm)
- 165-63225 ( $\varnothing 12$  mm)
- 165-63226 ( $\varnothing 16$  mm)
- 165-63227 ( $\varnothing 20$  mm)
- 165-63228 ( $\varnothing 25$  mm)

Boring bar sleeve  $\varnothing 40$  mm

- 165-64075 ( $\varnothing 8$  mm)
- 165-64076 ( $\varnothing 10$  mm)
- 165-64077 ( $\varnothing 12$  mm)
- 165-64078 ( $\varnothing 16$  mm)
- 165-64079 ( $\varnothing 20$  mm)
- 165-64080 ( $\varnothing 25$  mm)
- 165-64081 ( $\varnothing 32$  mm)

### Toolholder for insert drill

- E1-30x08WN ( $\varnothing 8$  mm)
- E1-30x10WN ( $\varnothing 10$  mm)
- E1-30x12WN ( $\varnothing 12$  mm)
- E1-30x16 ( $\varnothing 16$  mm)
- E1-30x20 ( $\varnothing 20$  mm)
- E1-30x25 ( $\varnothing 25$  mm)
- E1-30x32 ( $\varnothing 32$  mm)
- E1-30x40 ( $\varnothing 40$  mm)

### Toolholder for boring bar

- E2-30x6 ( $\varnothing 6$  mm)
- E2-30x8 ( $\varnothing 8$  mm)
- E2-30x10 ( $\varnothing 10$  mm)
- E2-30x12 ( $\varnothing 12$  mm)
- E2-30x16 ( $\varnothing 16$  mm)
- E2-30x20 ( $\varnothing 20$  mm)
- E2-30x25 ( $\varnothing 25$  mm)
- E2-30x32 ( $\varnothing 32$  mm)
- E2-30x40 ( $\varnothing 40$  mm)

### Double holder for boring bar

E7-30x25 ( $\varnothing 25$  mm)

### Toolholder with cylindrical shank

137-00041 ( $\varnothing 40$  mm/HSK50A+C)

### Collet chuck

- E4-30x16 (ER16)
- E4-30x20 (ER20)
- E4-30x25 (ER25)
- E4-30x32 (ER32)
- E4-30x40 (ER40)

### Drilling chuck

- KS2-30-13 ( $\varnothing 1$ - $\varnothing 13$  mm)
- KS2-30-16 ( $\varnothing 3$ - $\varnothing 16$  mm)

**DMG MORI**  
(VDI30)

CTX 310/410 V4/V6 - CTX 320 V4/V6  
 CTX 420 V4/V6 (option) - CTX Alpha 300 V4  
 CTX Alpha 500 V 4/V6  
 CTX Beta 500/800/1250 V4/V6 (option)  
 TWIN 42/65/102  
 SPRINT 65/50

**RADIAL TURRET**

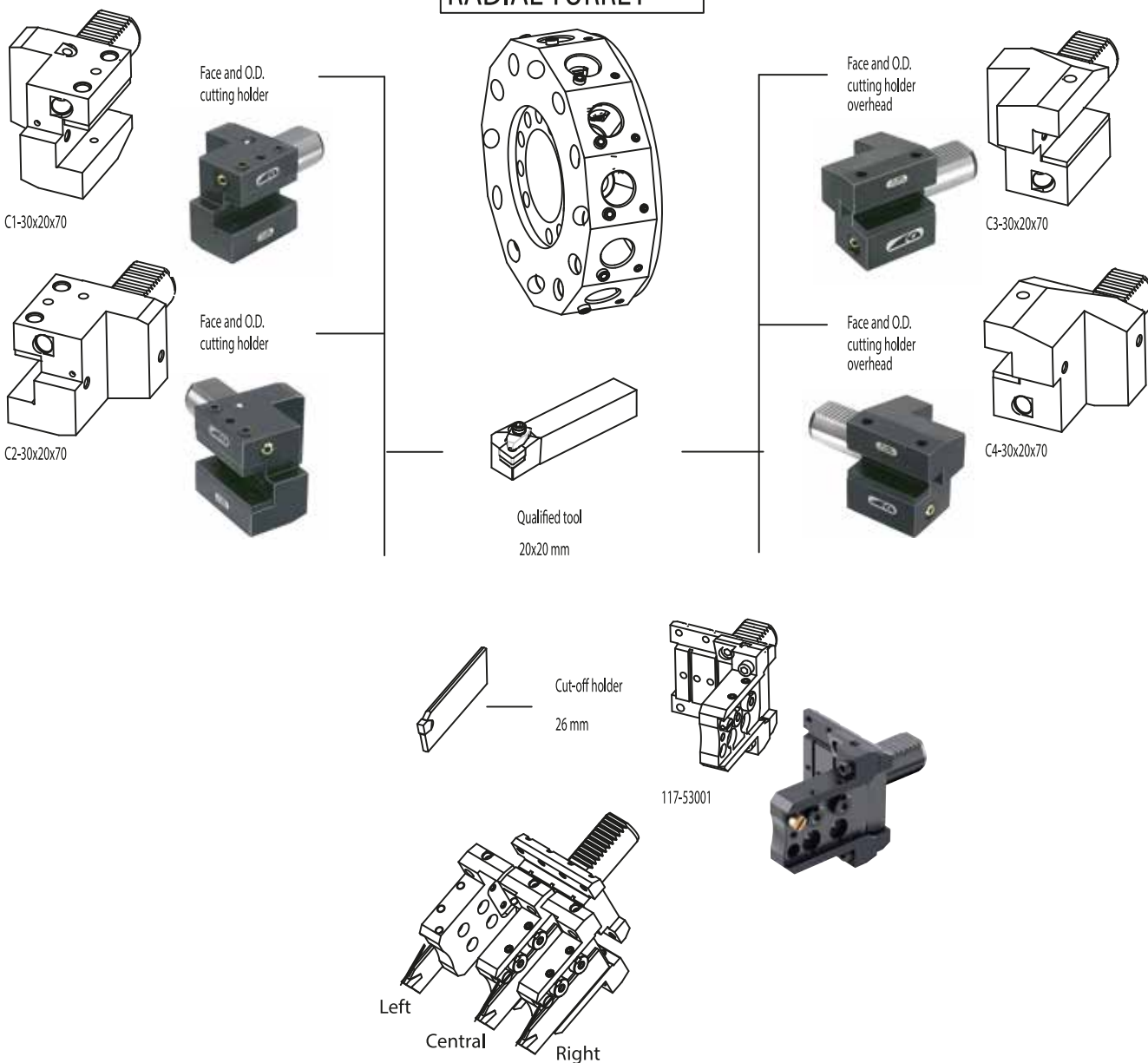

**DMG MORI**  
(VDI30)

CTX310/410 V4/V6 - CTX 320 V4/V6  
 CTX420 V4/V6 (option) - CTX Alpha 300 V4  
 CTX Alpha 500 V4/V6  
 CTX Beta 500/800/1250 V4/V6 (option)  
 TWIN 42/65/102  
 SPRINT 65/50

**RADIAL TURRET**

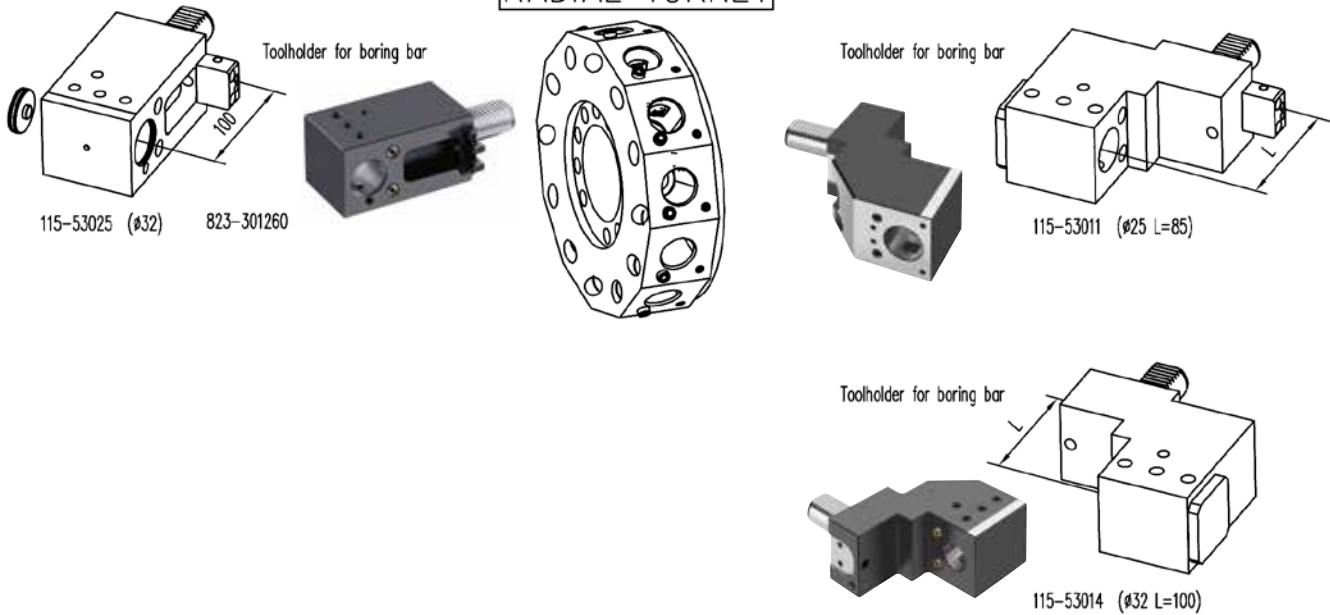

**ACCESSORIES**

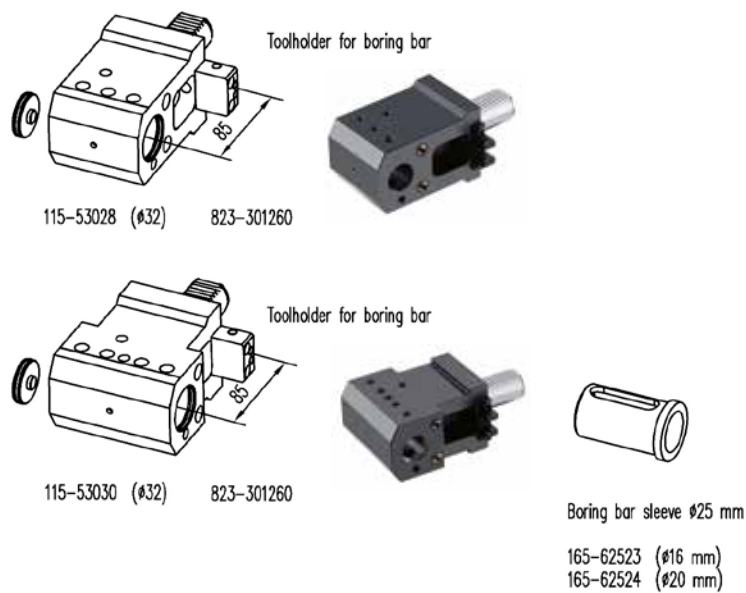

# DMG MORI (VDI40)

CTX410 V3 (option)  
 CTX510 V3/V4  
 CTX420 V3 (option)  
 CTX520 V3/V4  
 CTX Beta 500/800/1250 V3/V4  
 CTX Gamma 1250/2000 V3/V4 (option)

## AXIAL TURRET

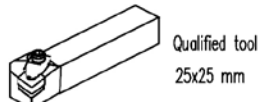
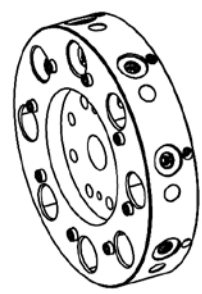
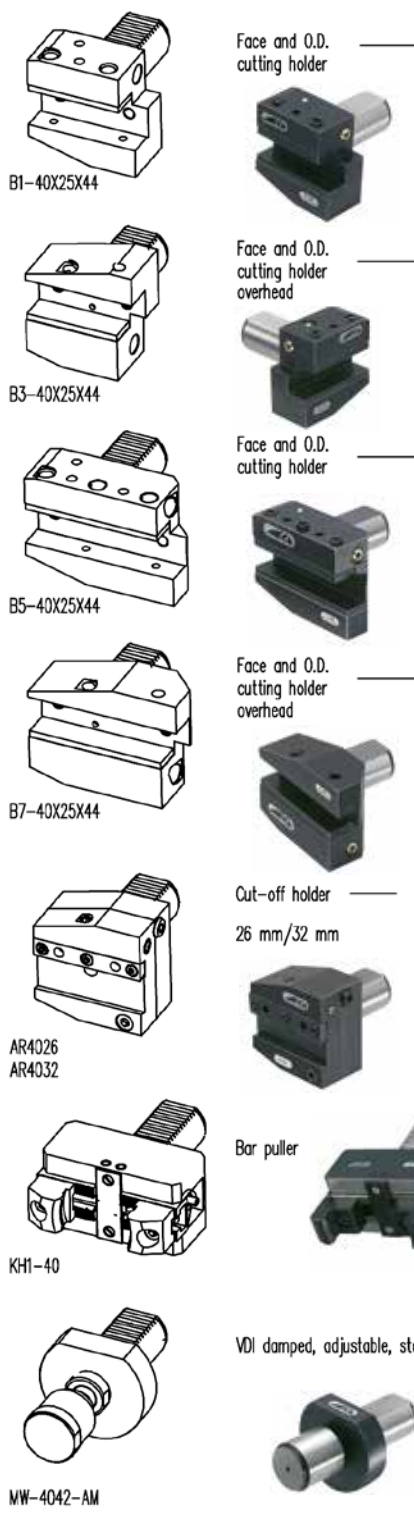

## ACCESSORIES

- Boring bar sleeve  $\varnothing 25$  mm
- 115-62579 ( $\varnothing 8$  mm)
  - 115-62580 ( $\varnothing 10$  mm)
  - 115-62581 ( $\varnothing 12$  mm)
  - 115-62582 ( $\varnothing 16$  mm)
  - 115-62583 ( $\varnothing 20$  mm)
- Boring bar sleeve  $\varnothing 32$  mm
- 165-63223 ( $\varnothing 8$  mm)
  - 165-63224 ( $\varnothing 10$  mm)
  - 165-63225 ( $\varnothing 12$  mm)
  - 165-63226 ( $\varnothing 16$  mm)
  - 165-63227 ( $\varnothing 20$  mm)
  - 165-63228 ( $\varnothing 25$  mm)

- Boring bar sleeve  $\varnothing 40$  mm
- 165-64082 ( $\varnothing 8$  mm)
  - 165-64083 ( $\varnothing 10$  mm)
  - 165-64084 ( $\varnothing 12$  mm)
  - 165-64085 ( $\varnothing 16$  mm)
  - 165-64086 ( $\varnothing 20$  mm)
  - 165-64087 ( $\varnothing 25$  mm)
  - 165-64088 ( $\varnothing 32$  mm)

- Toolholder for insert drill
- E1-40x06WN ( $\varnothing 6$  mm)
  - E1-40x08WN ( $\varnothing 8$  mm)
  - E1-40x10WN ( $\varnothing 10$  mm)
  - E1-40x12WN ( $\varnothing 12$  mm)
  - E1-40x16 ( $\varnothing 16$  mm)
  - E1-40x20 ( $\varnothing 20$  mm)
  - E1-40x25 ( $\varnothing 25$  mm)
  - E1-40x32 ( $\varnothing 32$  mm)
  - E1-40x40 ( $\varnothing 40$  mm)
  - E1-40x50 ( $\varnothing 50$  mm)

- Toolholder for boring bar
- E2-40x6 ( $\varnothing 6$  mm)
  - E2-40x8 ( $\varnothing 8$  mm)
  - E2-40x10 ( $\varnothing 10$  mm)
  - E2-40x12 ( $\varnothing 12$  mm)
  - E2-40x16 ( $\varnothing 16$  mm)
  - E2-40x20 ( $\varnothing 20$  mm)
  - E2-40x25 ( $\varnothing 25$  mm)
  - E2-40x32 ( $\varnothing 32$  mm)
  - E2-40x40 ( $\varnothing 40$  mm)
  - E2-40x50 ( $\varnothing 50$  mm)

- Double holder for boring bar  
 E7-40x32 ( $\varnothing 32$  mm)

- Collet chuck
- E4-40x20 (ER20)
  - E4-40x25 (ER25)
  - E4-40x32 (ER32)
  - E4-40x40 (ER40)

- Drilling chuck
- KS2-40-13 ( $\varnothing 1-13$  mm)
  - KS2-40-16 ( $\varnothing 3-16$  mm)

**DMG MORI  
(VDI40)**

CTX410 V4/V6 (option)  
 CTX420 V4/V6  
 CTXBeta 500/800/1250 V6  
 TWIN42/65/102 RG2  
 GMX250/300/400/500  
 SPRINT65 (option)

**RADIAL TURRET**

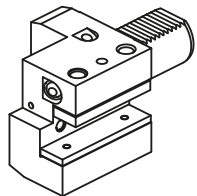

C1-40x25x85

Face and O.D.  
cutting holder

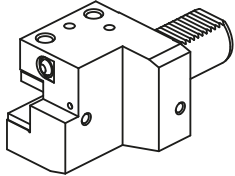

C2-40x25x85

Face and O.D.  
cutting holder

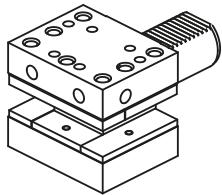

D1-40x25

Face and O.D.  
cutting holder

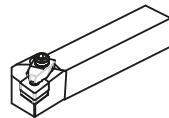
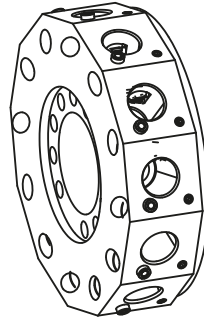

Qualified tool  
25x25 mm

Face and O.D.  
cutting holder

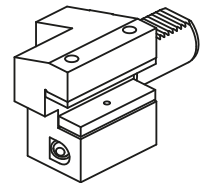

C3-40x25x85

Face and O.D.  
cutting holder

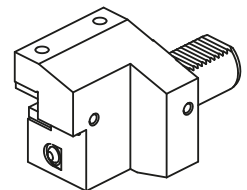

C4-40x25x85

Face and O.D.  
cutting holder

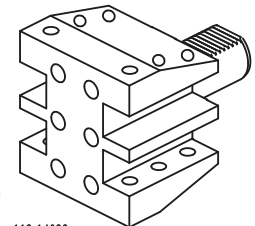

112-14022

Cut-off holder  
32 mm

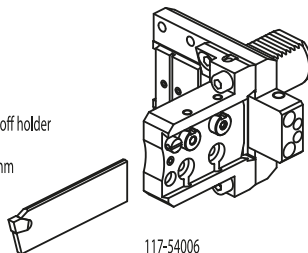

117-54006

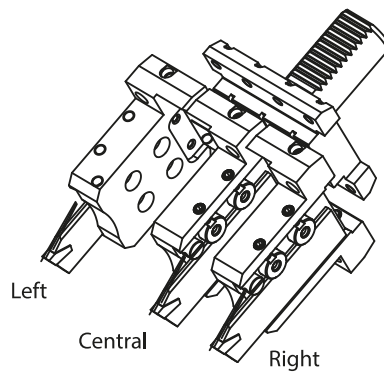

Left

Central

Right



**DMG MORI**  
(VDI40)

CTX410 V4/V6 (option)  
 CTX420 V4/V6  
 CTXBeta 500/800/1250 V4/V6  
 TWIN42/65/102 RG2  
 GMX250/300/400/500  
 SPRINT65 (option)

RADIAL TURRET

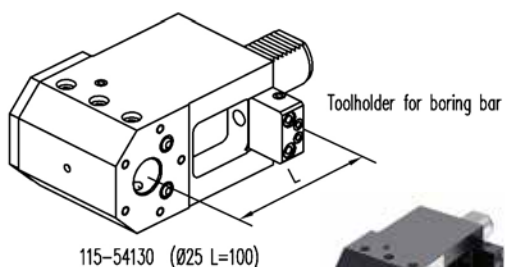

115-54130 (Ø25 L=100)

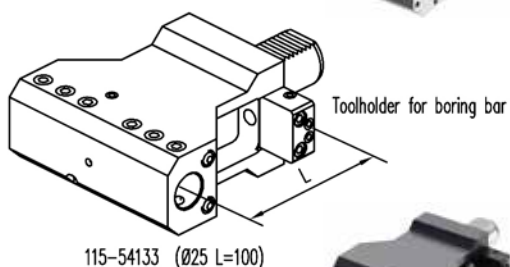

115-54133 (Ø25 L=100)

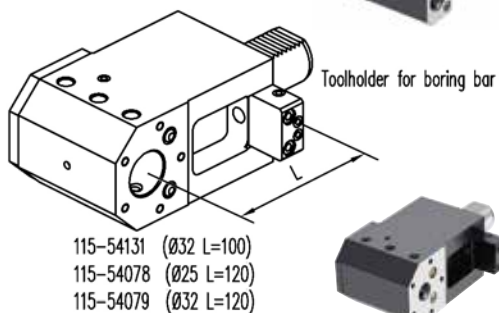

115-54131 (Ø32 L=100)  
 115-54078 (Ø25 L=120)  
 115-54079 (Ø32 L=120)

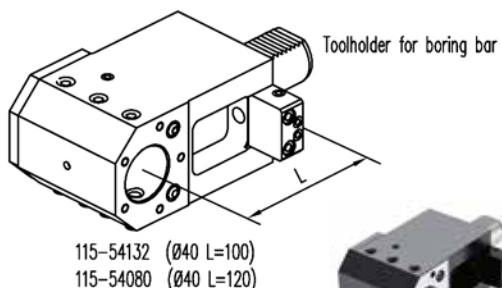

115-54132 (Ø40 L=100)  
 115-54080 (Ø40 L=120)

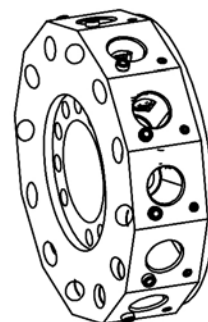

ACCESSORIES



Boring bar sleeve (Ø25)

- 115-62579 (Ø8)
- 115-62580 (Ø10)
- 115-62581 (Ø12)
- 115-62582 (Ø16)
- 115-62583 (Ø20)



Boring bar sleeve (Ø32)

- 165-63223 (Ø8)
- 165-63224 (Ø10)
- 165-63225 (Ø12)
- 165-63226 (Ø16)
- 165-63227 (Ø20)
- 165-63228 (Ø25)



Boring bar sleeve (Ø40)

- 165-64082 (Ø8)
- 165-64083 (Ø10)
- 165-64084 (Ø12)
- 165-64085 (Ø16)
- 165-64086 (Ø20)
- 165-64087 (Ø25)
- 165-64088 (Ø32)

Double toolholder for boring bar

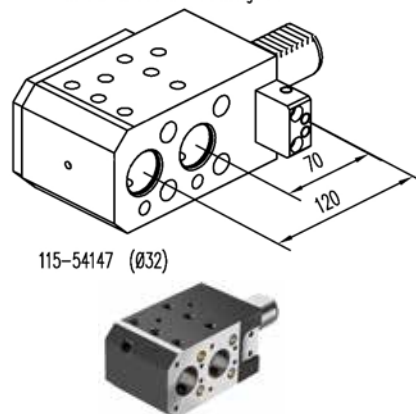

115-54147 (Ø32)

**DMG MORI**  
(VDI50)

CTX620 V3/V4/V1  
CTX Gamma 1250/2000 V3/V4  
CTV400  
CTX Beta 2000

**AXIAL TURRET**

**Face and O.D. cutting holder**

B1-50x32x55

**Face and O.D. cutting holder overhead**

B3-50x32x55

**Face and O.D. cutting holder**

B5-50x32x55

**Face and O.D. cutting holder overhead**

B7-50x32x55

**Out-off holder**  
26 mm/32 mm

AR5026  
AR5032

**Bar puller**

KH1-50

**VDI damped, adjustable, stop bar**

MW-5042-AM

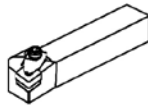
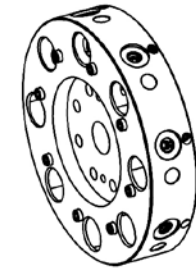

Qualified tool  
32x32 mm



Boring bar sleeve  $\varnothing 25$  mm

- 115-62584 ( $\varnothing 8$  mm)
- 115-62585 ( $\varnothing 10$  mm)
- 115-62586 ( $\varnothing 12$  mm)
- 115-62587 ( $\varnothing 16$  mm)
- 115-62588 ( $\varnothing 20$  mm)

Boring bar sleeve  $\varnothing 32$  mm

- 165-63229 ( $\varnothing 8$  mm)
- 165-63230 ( $\varnothing 10$  mm)
- 165-63231 ( $\varnothing 12$  mm)
- 165-63232 ( $\varnothing 16$  mm)
- 165-63233 ( $\varnothing 20$  mm)
- 165-63234 ( $\varnothing 25$  mm)

Boring bar sleeve  $\varnothing 40$  mm

- 165-64082 ( $\varnothing 8$  mm)
- 165-64083 ( $\varnothing 10$  mm)
- 165-64084 ( $\varnothing 12$  mm)
- 165-64085 ( $\varnothing 16$  mm)
- 165-64086 ( $\varnothing 20$  mm)
- 165-64087 ( $\varnothing 25$  mm)
- 165-64088 ( $\varnothing 32$  mm)

**Toolholder for insert drill**

- E1-50x16 ( $\varnothing 16$  mm)
- E1-50x20 ( $\varnothing 20$  mm)
- E1-50x25 ( $\varnothing 25$  mm)
- E1-50x32 ( $\varnothing 32$  mm)
- E1-50x40 ( $\varnothing 40$  mm)
- E1-50x50 ( $\varnothing 50$  mm)

**Toolholder for boring bar**

- E2-50x12 ( $\varnothing 12$  mm)
- E2-50x16 ( $\varnothing 16$  mm)
- E2-50x20 ( $\varnothing 20$  mm)
- E2-50x25 ( $\varnothing 25$  mm)
- E2-50x32 ( $\varnothing 32$  mm)
- E2-50x40 ( $\varnothing 40$  mm)
- E2-50x50 ( $\varnothing 50$  mm)

**Double holder for boring bar**

- E7-50x32 ( $\varnothing 32$  mm L=50 mm)
- E7-50x50 ( $\varnothing 50$  mm L=68 mm)

**Collet chuck**

- E4-50x25 (ER25)
- E4-50x32 (ER32)
- E4-50x40 (ER40)

**Drilling chuck**

- KS2-50-13 ( $\varnothing 1$ - $\varnothing 13$  mm)
- KS2-50-16 ( $\varnothing 3$ - $\varnothing 16$  mm)

**ACCESSORIES**

**DMG MORI**  
(HSK63T)

GMX400  
GMX300  
GMX250

ATC Turret (HSK63T)

ICTM STANDARD

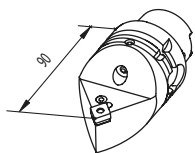

H63APCMNR12-90

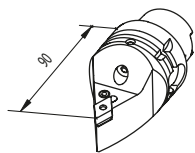

H63APDNNR15-90

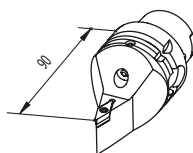

H63ASVVCN16-90

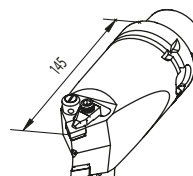

H63ADCM12DDM15-L145

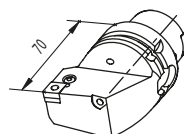

H63APCLNL/R12

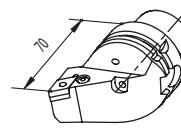

H63APDJNL/R15

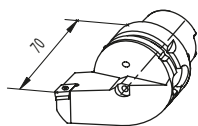

H63ASDJCL/R11

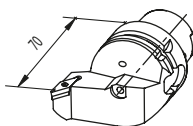

H63ASVJBL/R16

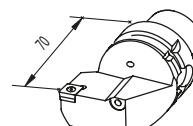

H63ASCLCL/R12

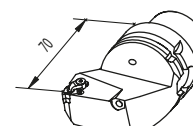

H63ATHEL/R16

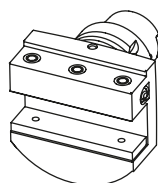

141-11408 32/25

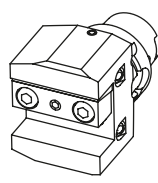

141-11406 25x25 mm

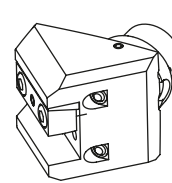

141-11405 25x25 mm

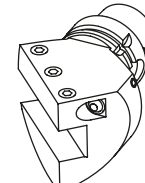

141-11407 (left) 25x25 mm  
141-21401 (right)

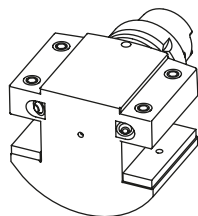

142-11405 32/25  
142-11406 32/25

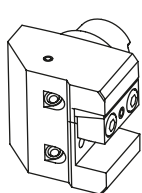

142-11402 25x25 mm

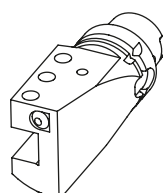

142-21401 (left) 25x25 mm  
142-11403 (right)

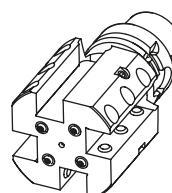

142-21404 20x20 mm (right)  
142-21403 20x20 mm (left)

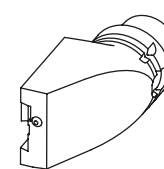

147-51405 (26mm, left)  
147-51406 (26mm, right)  
147-51407 (32mm, left)  
147-51408 (32mm, right)

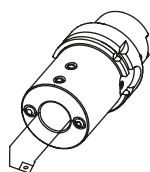

145-21404 (Ø12)  
145-21406 (Ø16)  
145-21408 (Ø20)  
145-21409 (Ø25)  
145-21410 (Ø32)  
145-21411 (Ø40)

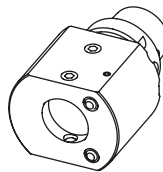

145-21412 Ø40 mm



165-64124 (Ø10 mm)  
165-64125 (Ø12 mm)  
165-64126 (Ø16 mm)  
165-64127 (Ø20 mm)



165-64128 (Ø25 mm)  
165-64129 (Ø32 mm)

**DMG MORI  
(BMT40)**

CTX310ECO-BMT  
NZ1500  
NZ2000  
NTX1000-2000

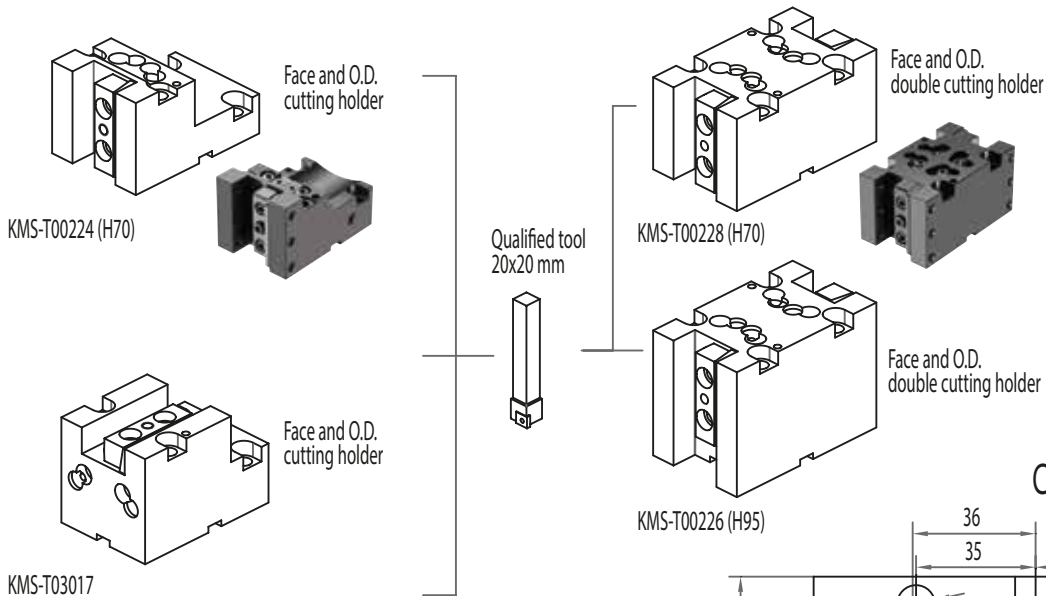

**CONNECTION**

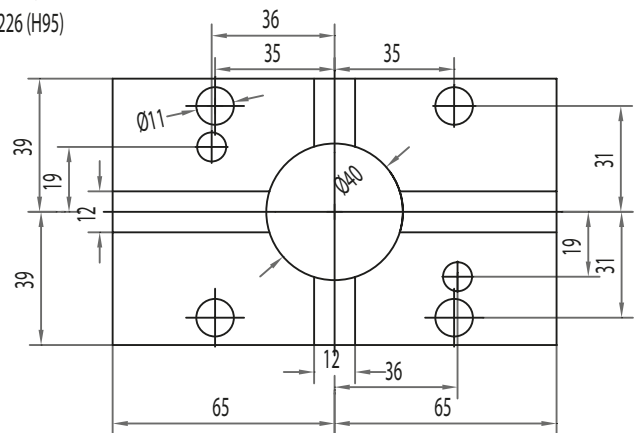

**ACCESSORIES**

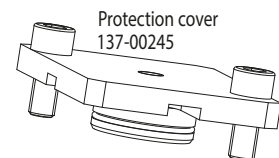
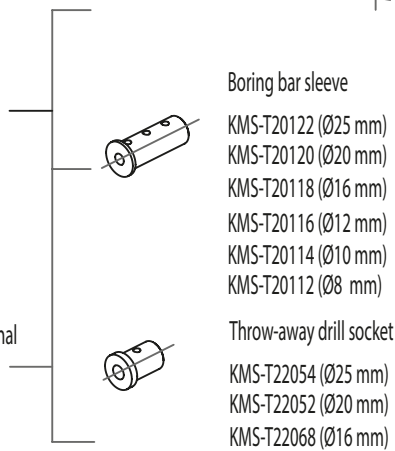
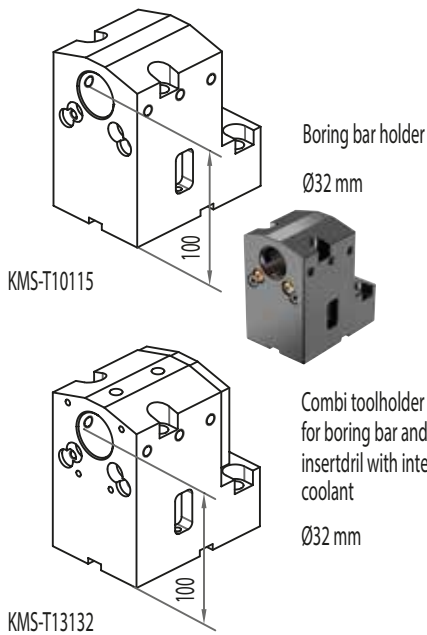

# DMG MORI (BMT60)

NLX1500 - NLX2000  
 NLX2500 - NLX3000  
 NL2000 (S)MC - 2500 (S)MC  
 NL3000MC (12 STATIONS)  
 NT3250 - NT4200 - NT4250  
 NT4300 - NT5400 - NZL2500

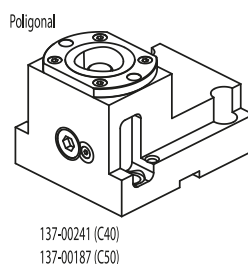
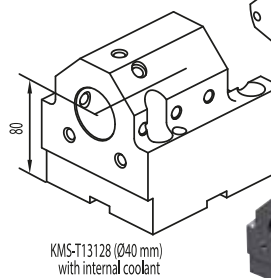
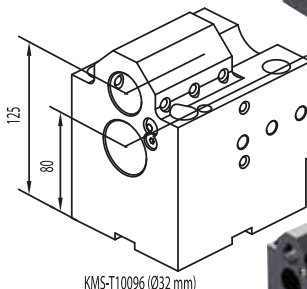
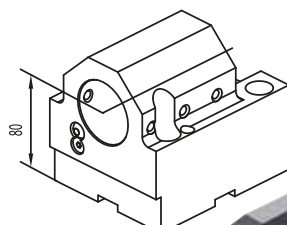
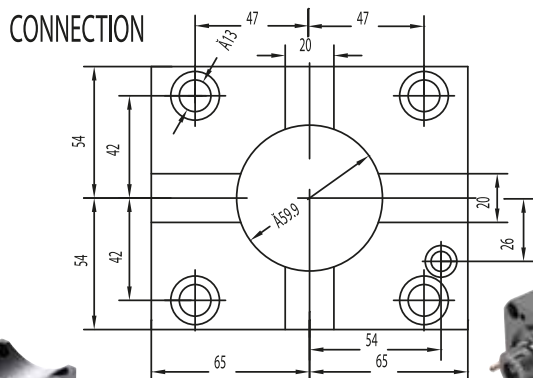
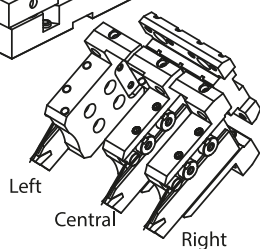
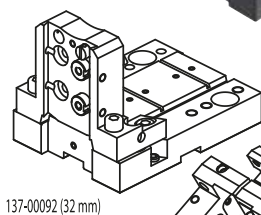
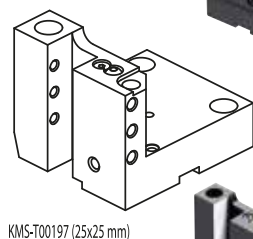
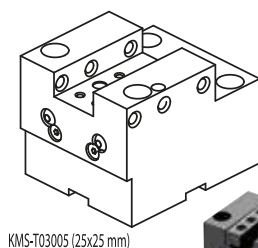
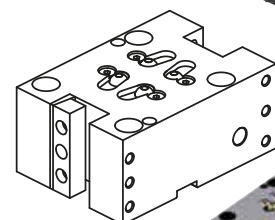
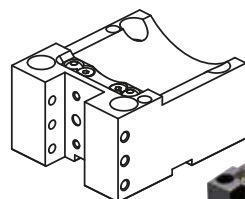
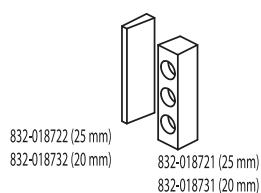

## ACCESSORIES

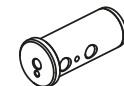
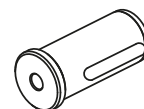
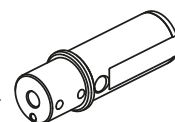
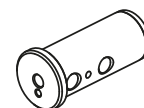

- KMS-T20098-A (Ø32 mm)
- KMS-T20096-A (Ø25 mm)
- KMS-T20094-A (Ø20 mm)
- KMS-T20092-A (Ø16 mm)
- KMS-T20090-A (Ø12 mm)
- KMS-T20088-A (Ø10 mm)
- KMS-T20086-A (Ø8 mm)

- KMS-T20196-A (Ø20 mm)
- KMS-T20194-A (Ø16 mm)
- KMS-T20110-A (Ø12 mm)
- KMS-T20108-A (Ø10 mm)
- KMS-T20106-A (Ø8 mm)

- KMS-T22042-A (MT3)
- KMS-T22044-A (MT4)
- KMS-T22046-A (MT2)
- KMS-T22066-A (MT1)

- KMS-T20122-A (Ø25 mm)
- KMS-T20120-A (Ø20 mm)
- KMS-T20118-A (Ø16 mm)
- KMS-T20116-A (Ø12 mm)
- KMS-T20114-A (Ø10 mm)
- KMS-T20112-A (Ø8 mm)

- KMS-T20100-A (Ø32 mm)
- KMS-T20102-A (Ø25 mm)
- KMS-T20104-A (Ø20 mm)
- KMS-T20190-A (Ø16 mm)

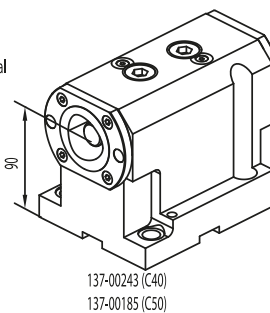
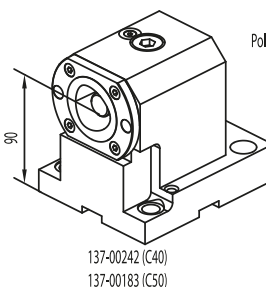

NEWS

NEWS

NEWS



**DMG MORI**

SL203MC  
SL253MC  
ZL200MC  
ZL250SMC  
SL204SMC  
SL300MC

**CMZ**

TL20  
TL25  
TC30  
TC35

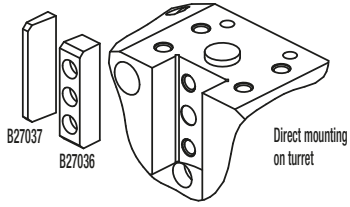

Direct mounting on turret

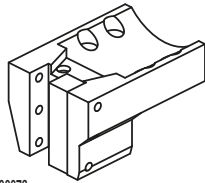

Face and O.D. cutting holder

KMS-T00076

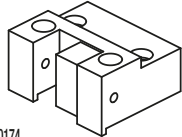

Face and O.D. cutting holder

KMS-T00174

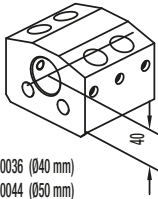

Boring bar holder

KMS-T10036 (Ø40 mm)  
KMS-T10044 (Ø50 mm)

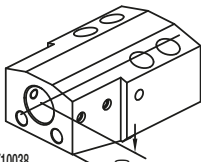

Boring bar holder Ø40 mm

KMS-T10038

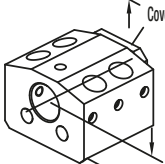

Combi toolholder for boring bar and insertdrill with internal coolant Ø40 mm

KMS-T13064

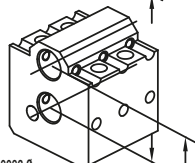

Boring bar holder Ø32 mm

KMS-T10086 Ø

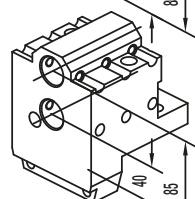

Boring bar holder Ø32 mm

KMS-T10208

Qualified tool 25x25 mm

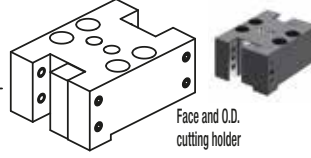

Face and O.D. cutting holder

KMS-T00158

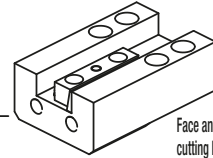

Face and I.D. cutting holder

KMS-T00082



Cut-off holder

KMS-T00156

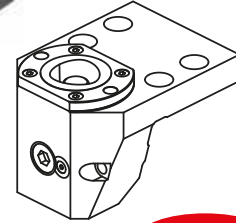

Face and O.D. cutting holder

Polygonal

128-12527 (C40)  
128-12513 (C50)

**NEWS**

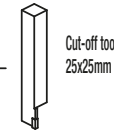

Cut-off tool 25x25mm

**ACCESSORIES**



Drill socket

KMS-T22042 <MT3>  
KMS-T22044 (for Ø50 mm) <MT4>  
KMS-T22046 <MT2>



Boring bar sleeve

KMS-T20098 (Ø32 mm)  
KMS-T20096 (Ø25 mm)  
KMS-T20094 (Ø20 mm)  
KMS-T20092 (Ø16 mm)  
KMS-T20090 (Ø12 mm)  
KMS-T20088 (Ø10 mm)  
KMS-T20086 (Ø8 mm)



Throw-away drill socket

KMS-T20100 (Ø32 mm)  
KMS-T20102 (Ø25 mm)  
KMS-T20104 (Ø20 mm)  
KMS-T20190 (Ø16 mm)



Boring bar sleeve

KMS-T20122 (Ø25 mm)  
KMS-T20120 (Ø20 mm)  
KMS-T20118 (Ø16 mm)  
KMS-T20116 (Ø12 mm)  
KMS-T20114 (Ø10 mm)  
KMS-T20112 (Ø8 mm)



Drill socket

KMS-T22048 <MT2>  
KMS-T22050 <MT1>

**CONNECTION**

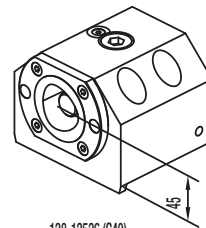
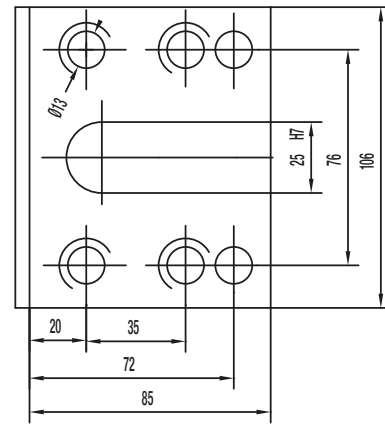

Boring bar holder  
Polygonal

128-12526 (C40)  
128-12509 (C50)

**NEWS**

**DMG MORI** CTX Gamma 1250TC/2000TC

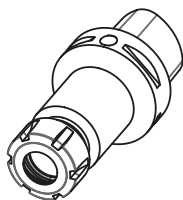

C63H60ER16 C63H100ER16  
C63H60ER20 C63H100ER20  
C63H60ER25 C63H100ER25  
C63H60ER32 C63H100ER32  
C63H70ER40 C63H130ER40



C63H55WE06 C63H65WE16  
C63H55WE08 C63H65WE20  
C63H60WE10 C63H80WE25  
C63H60WE12 C63H90WE32  
C63H60WE14



C63H40D16 C63H100D27  
C63H63D16 C63H25D32  
C63H25D22 C63H100D32  
C63H100D22 C63H40D40  
C63H25D27 C63H100D40

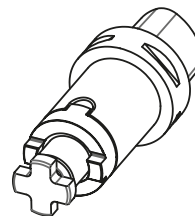

C63H90D16  
C63H90D22  
C63H90D27  
C63H90D32  
C63H90D40

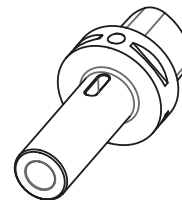

C63H110CM2P  
C63H130CM3P  
C63H150CM4P



C63H112R1-13  
C63H112R3-16



C63GR1  
C63GR2

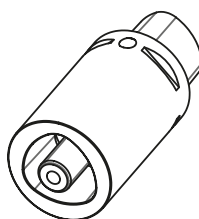

C63H100C63  
C63H140C63



C63H60D08PNT C63H70D20PNT  
C63H60D10PNT C63H72D25PNT  
C63H60D12PNT C63H75D32PNT  
C63H70D16PNT C63H75D40PNT

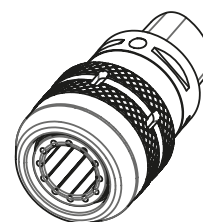

C63H80C20  
C63H100C32

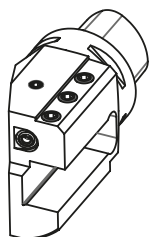

C63-AD2020R/L  
C63-AD2525R/L  
C63-AD3232R/L

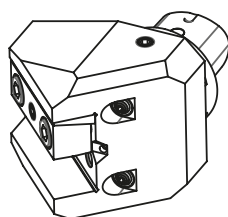

C63-ARD2525-45

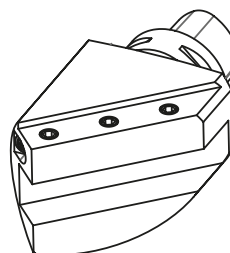

C63AR20R/L  
C63AR25R/L

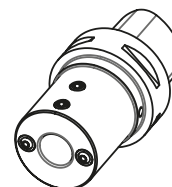

C63H80D16E2  
C63H80D20E2  
C63H88D25E2  
C63H95D32E2  
C63H105D40E2

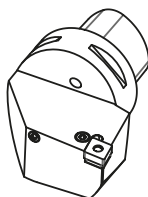

C63-PCLNR/L12



C63-25PCLNR/L12  
C63-32PCLNR/L12

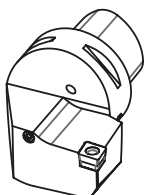

C63-SCLCR/L09  
C63-SCLCR/R12

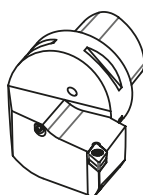

C63-SDJCR/L11

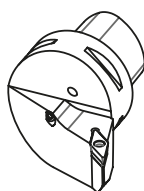

C63-SVHBR/L16  
C63-SVHCR/L16

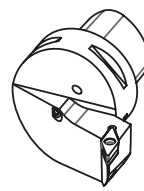

C63-SVJBR/L16  
C63-SVJCR/L16

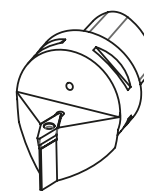

C63-SVVCN16-190

**DMG MORI**

SL150  
SL153  
ZL150  
CL150  
SL154

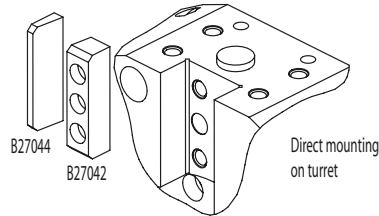

B27044  
B27042

Direct mounting  
on turret

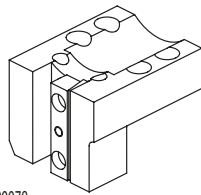

KMS-T00078

Face and O.D.  
cutting holder  
(Only for CL-150)



**ACCESSORIES**

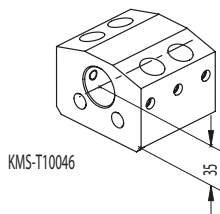

KMS-T10046

Boring bar holder  
Ø32 mm

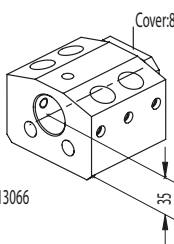

KMS-T13066

Cover: B32-003062

Combi toolholder  
for boring bar and  
insert drill with internal  
coolant  
Ø32 mm

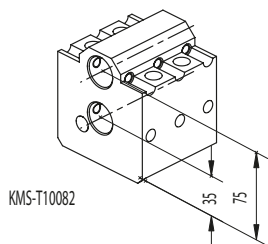

KMS-T10082

Boring bar holder  
Ø25 mm

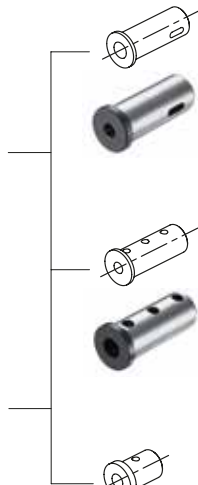

Drill socket

KMS-T22048 <MT2>

Boring bar sleeve

KMS-T20122 (Ø25 mm)  
KMS-T20120 (Ø20 mm)  
KMS-T20118 (Ø16 mm)  
KMS-T20116 (Ø12 mm)  
KMS-T20114 (Ø10 mm)  
KMS-T20112 (Ø8 mm)

Throw-away drill socket

KMS-T22054 (Ø25 mm)  
KMS-T22052 (Ø20 mm)  
KMS-T22068 (Ø16 mm)

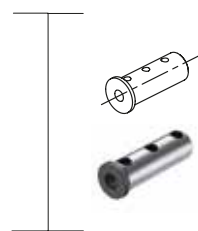

Boring bar sleeve

KMS-T20188 (Ø20 mm)  
KMS-T20186 (Ø16 mm)  
KMS-T20184 (Ø12 mm)  
KMS-T20182 (Ø10 mm)  
KMS-T20180 (Ø8 mm)

**CONNECTION**

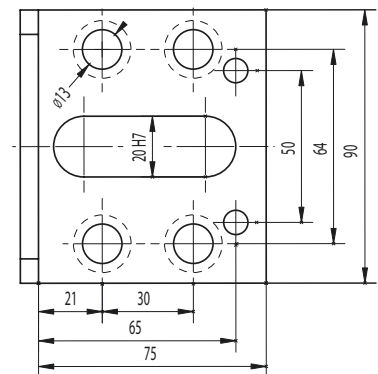

**DMG MORI**

SL153MC  
ZL150MC  
SL154MC

**CMZ** TL15

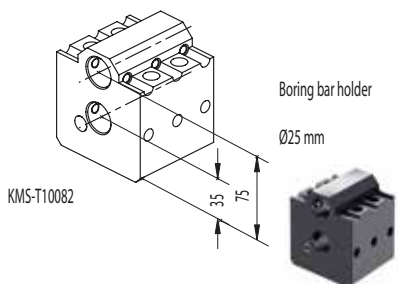
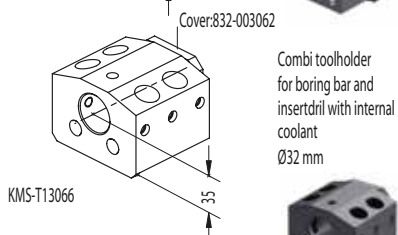
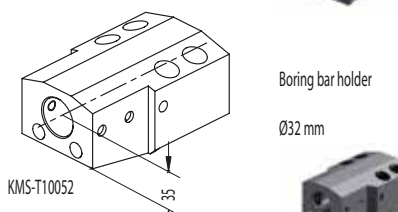
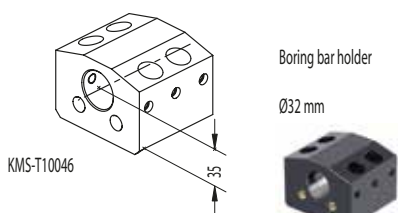
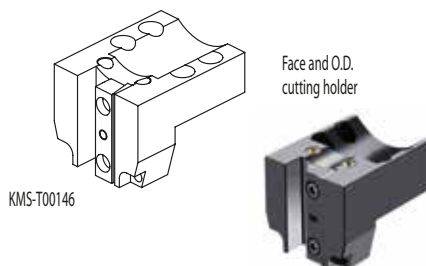
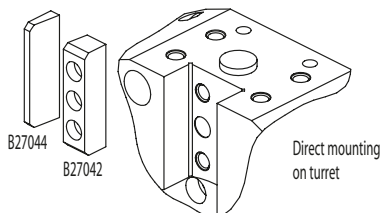

**ACCESSORIES**

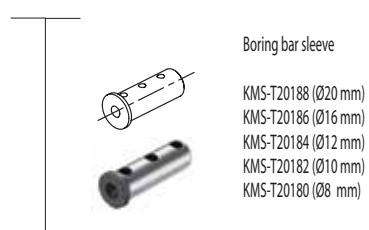
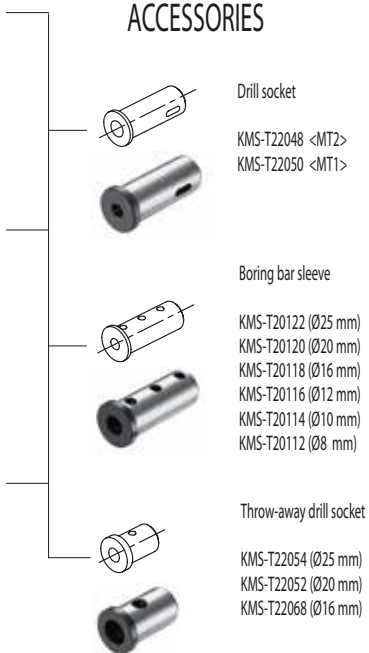

**CONNECTION**

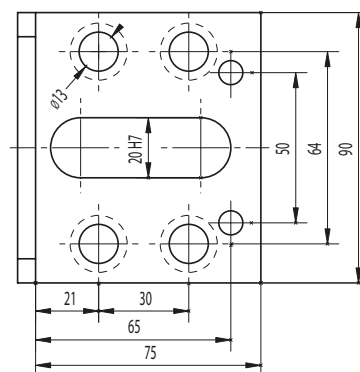

**DMG MORI**

SL200 - SL203 - SL250  
 SL253 - ZL200 - ZL250  
 (CL200) - SL204  
 DURATURN 2030  
 DURATURN 2050  
 DURATURN 2550

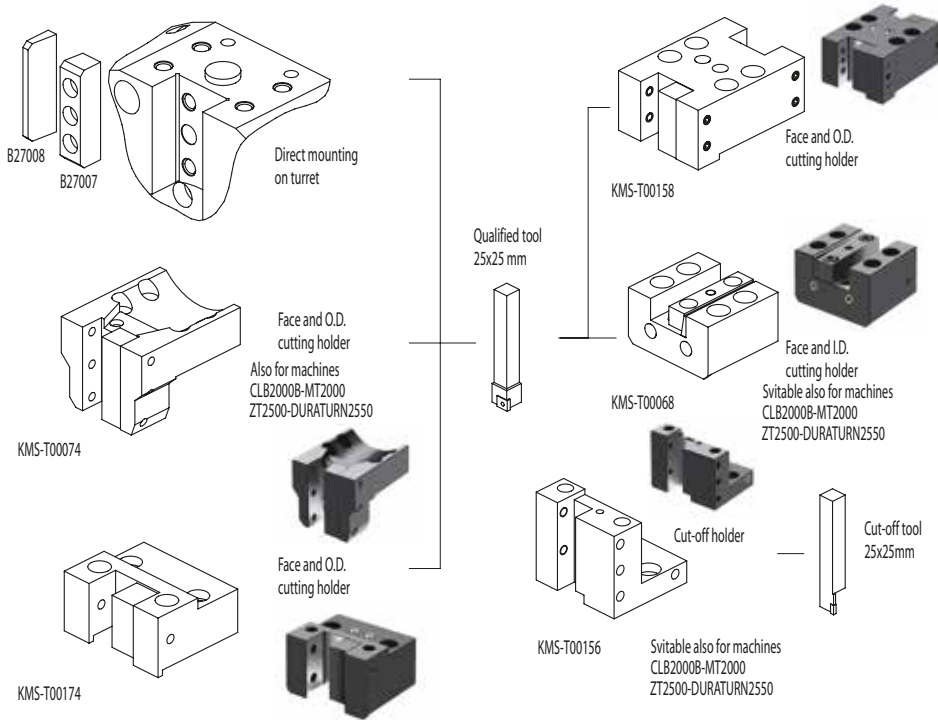

**ACCESSORIES**

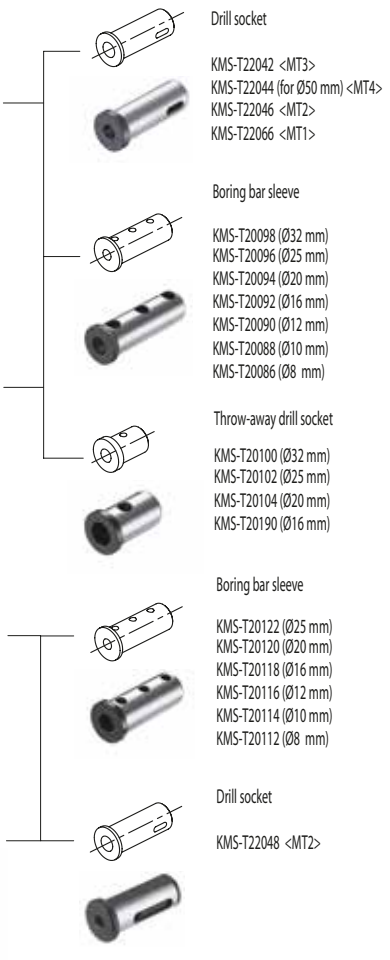
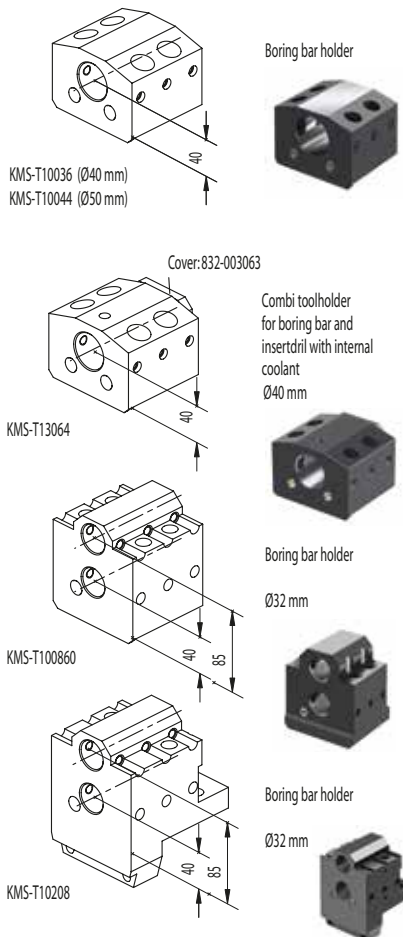

**CONNECTION**

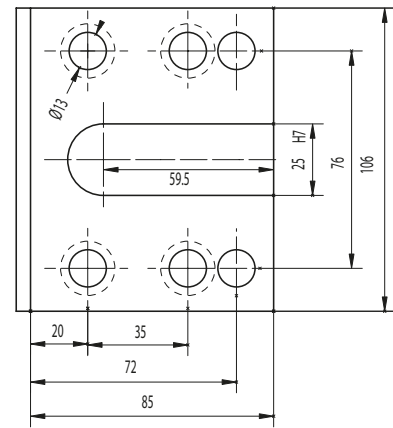



**OKUMA**  
(VDI30)

LT10M  
LT200M  
LB10

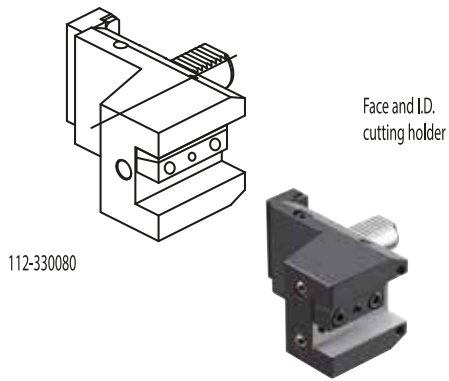

Face and I.D.  
cutting holder

112-330080

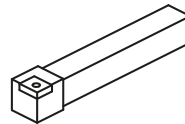

Qualified tool  
20x20 mm

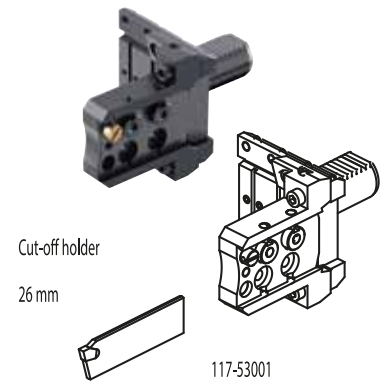

Cut-off holder  
26 mm

117-53001

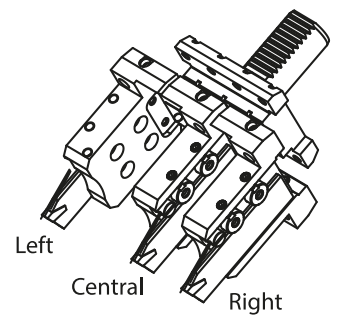

Left

Central

Right

ACCESSORIES

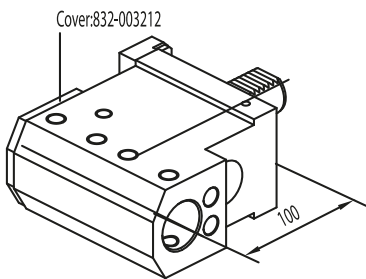

Cover:832-003212

115-23045

Combi toolholder  
for boring bar and  
insertdrill with internal  
coolant

Ø32 mm

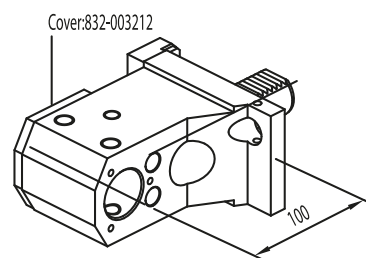

Cover:832-003212

115-23046

Combi toolholder  
for boring bar and  
insertdrill with internal  
coolant

Ø32 mm

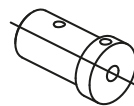

Boring bar sleeve

115-63286 (Ø8 mm)  
115-63288 (Ø10 mm)  
115-63290 (Ø12 mm)

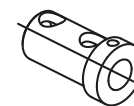

Boring bar sleeve

115-63292 (Ø16 mm)  
115-63294 (Ø20 mm)  
115-63296 (Ø25 mm)



**OKUMA  
(VDI40)**

LT15M  
LT300M  
MT250  
LB300  
LB300M  
LV300

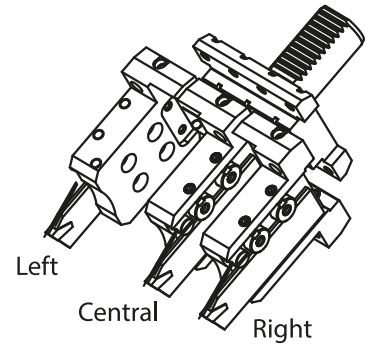
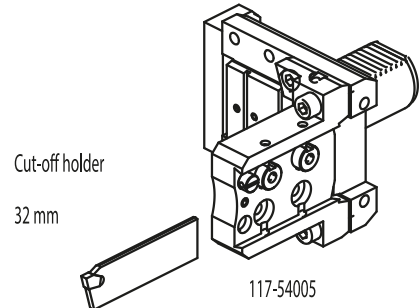
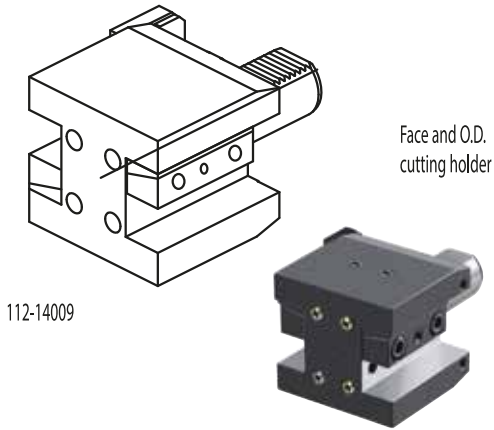

11

**ACCESSORIES**

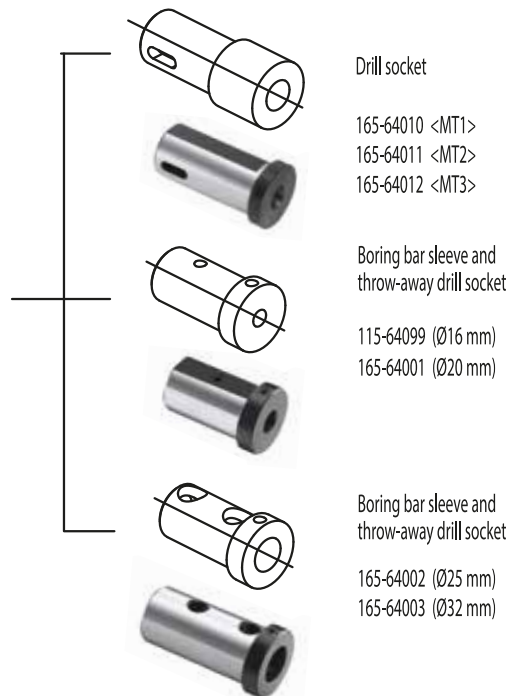
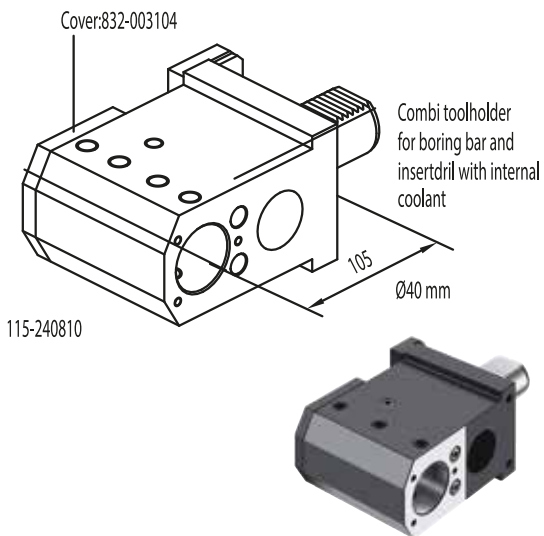

# OKUMA

LB15  
LB25  
LB15II  
LB300

# HAAS

SL20 - SL30  
ST-20 - ST-25  
ST-30 - ST-35  
DS-30

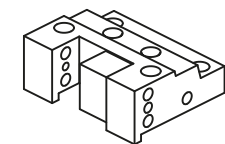

128-42011 Ø

Face and O.D. cutting holder



Face and I.D. cutting holder

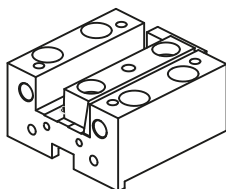

128-32001

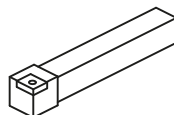

Qualified tool  
25x25 mm

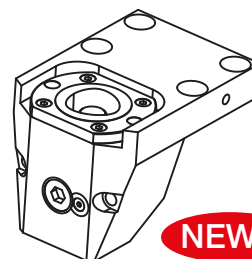

128-12072 (C40)  
128-12059 (C50)

Face and O.D. cutting holder

Poligonal

**NEWS**

## CONNECTION

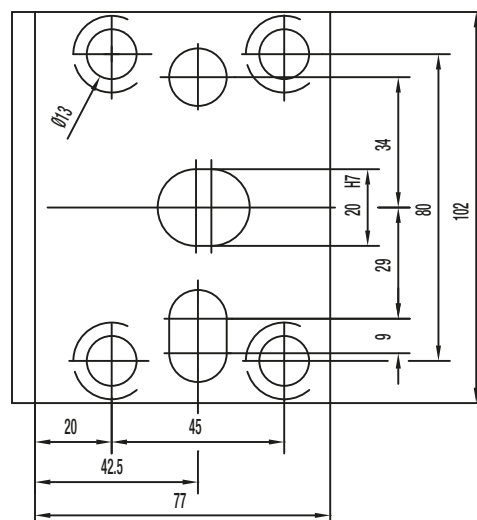

## ACCESSORIES

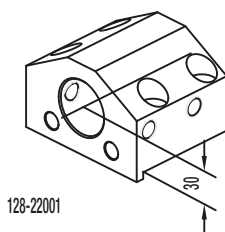

128-22001

Toolholder for boring bar

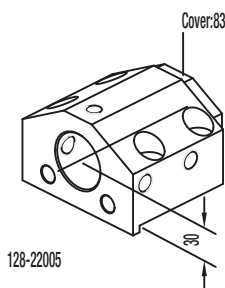

128-22005

Cover: 832-003056

Combi toolholder for boring bar and insertdrill with internal coolant



Drill socket

165-64010 <MT1>  
165-64011 <MT2>  
165-64012 <MT3>

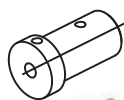

Boring bar sleeve and throw-away drill socket

165-64135 (Ø8 mm)  
165-64013 (Ø10 mm)  
165-64014 (Ø12 mm)  
165-64015 (Ø16 mm)  
165-64016 (Ø20 mm)

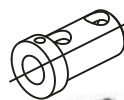

Boring bar sleeve and throw-away drill socket

165-64017 (Ø25 mm)  
165-64018 (Ø32 mm)

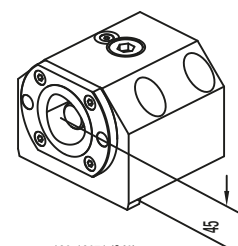

128-12071 (C40)  
128-12057 (C50)

Boring bar holder

Poligonal

**NEWS**

**OKUMA  
(HSK63T)**

Mac Turn 250/350/400  
Multus B250/B300/B400

For turning

ATC Turret (HSK63T)

ICTM STANDARD

45°

90°

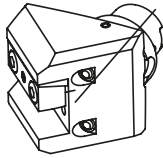

141-11405 25x25 mm

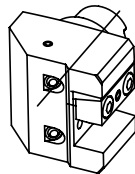

142-11402 25x25 mm

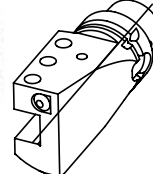

142-21401 (left)  
142-11403 (right) 25x25 mm

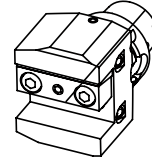

141-11406 25x25 mm

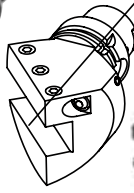

141-11407 (left)  
141-21401 (right) 25x25 mm

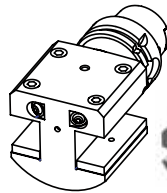

142-11405 32x32/25x25 mm

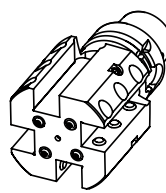

142-21403 20x20 mm (left)  
142-21404 20x20 mm (right)

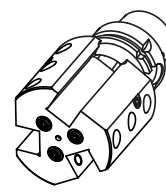

142-21402 20x20 mm (left)  
142-11404 20x20 mm (right)

CUT-OFF HOLDER

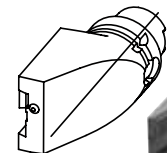

147-51405 (26mm, left)  
147-51406 (26mm, right)  
147-51407 (32mm, left)  
147-51408 (32mm, right)

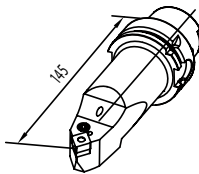

H63APCMNR12-L145

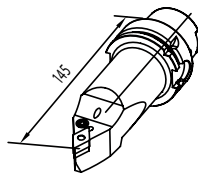

H63APDNNR15-L145

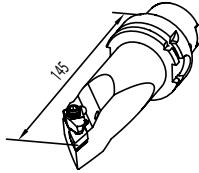

H63ADDMNL15-L145

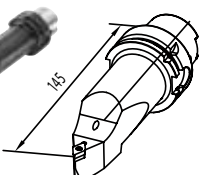

H63ASDNCN11-L145

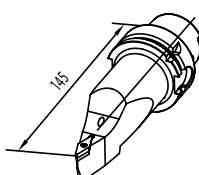

H63ASVVCN16-L145



BORING BAR HOLDER

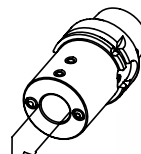

145-21404 (Ø12)  
145-21406 (Ø16)  
145-21408 (Ø20)  
145-21409 (Ø25)  
145-21410 (Ø32)  
145-21411 (Ø40)

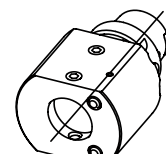

145-21412 Ø40 mm

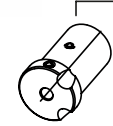

165-64124 (Ø10 mm)  
165-64125 (Ø12 mm)  
165-64126 (Ø16 mm)  
165-64127 (Ø20 mm)

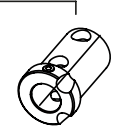

165-64128 (Ø25 mm)  
165-64129 (Ø32 mm)

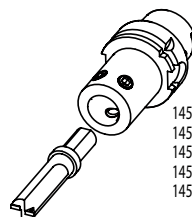

145-11406 (Ø16)  
145-11408 (Ø20)  
145-11409 (Ø25)  
145-11410 (Ø32)  
145-11411 (Ø40)



**OKUMA**  
(VDI40)

Mac Turn 250/350

Lower Turret (VDI 40)

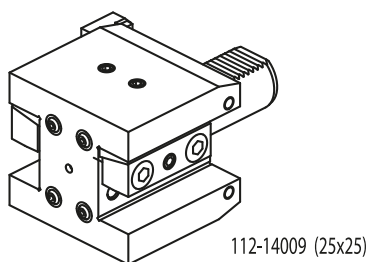

112-14009 (25x25)

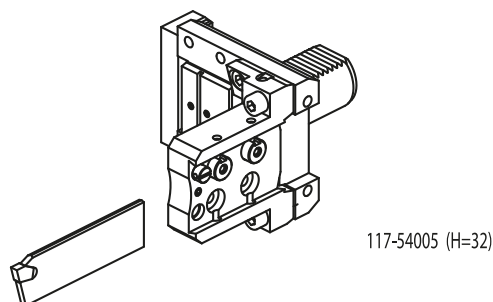

117-54005 (H=32)

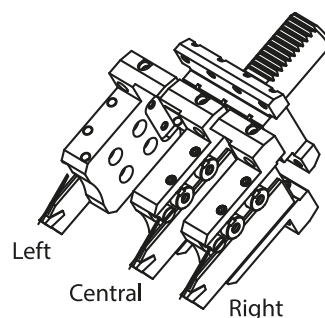

Left  
Central  
Right

ACCESSORIES

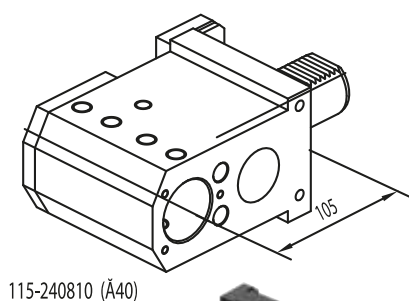

115-240810 (A40)

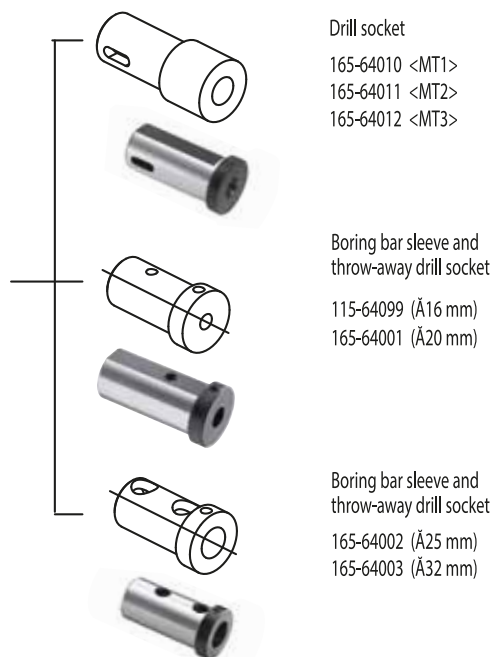

Drill socket  
165-64010 <MT1>  
165-64011 <MT2>  
165-64012 <MT3>

Boring bar sleeve and  
throw-away drill socket  
115-64099 (A16 mm)  
165-64001 (A20 mm)

Boring bar sleeve and  
throw-away drill socket  
165-64002 (A25 mm)  
165-64003 (A32 mm)



**OKUMA**  
(HSK100A) Mac Turn 550

For turning

ATC Turret (HSK100A) ICTM STANDARD

45°

90°

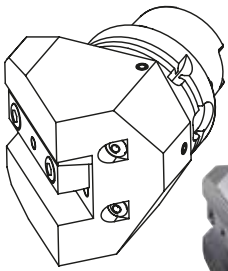

141-11603 25x25 mm

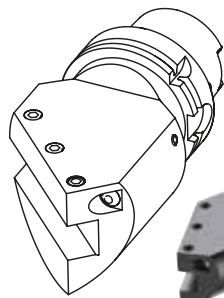

141-11601 25x25 mm

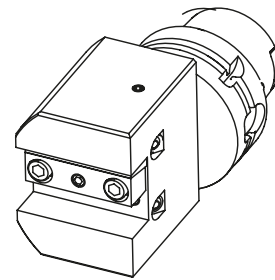

141-11602 25x25 mm

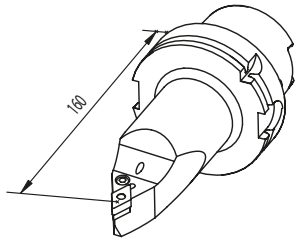

H100APDNNR15-L160

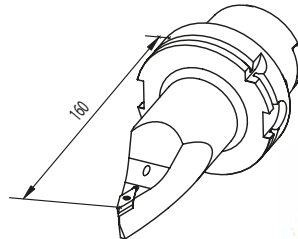

H100ASVVCN16-L160



**OKUMA**  
(BMT60)

LB2000 EX (M)  
LB2500 EX (M)  
LB3000 EX (M, MY)  
LT2000 EX  
LT3000 EX

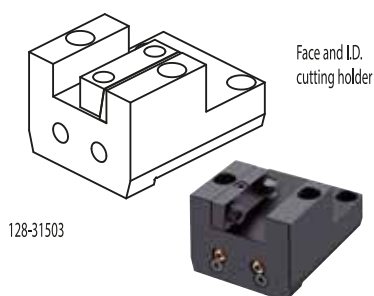
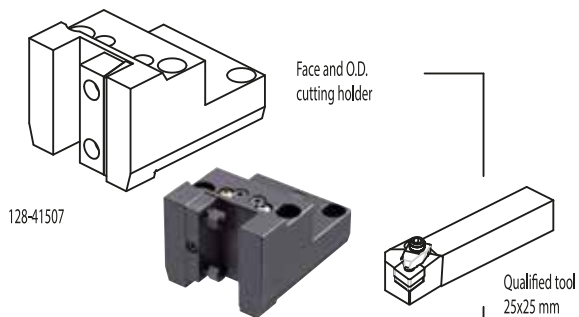

124-06006 I.Coolant



124-06008 I.Coolant

CONNECTION

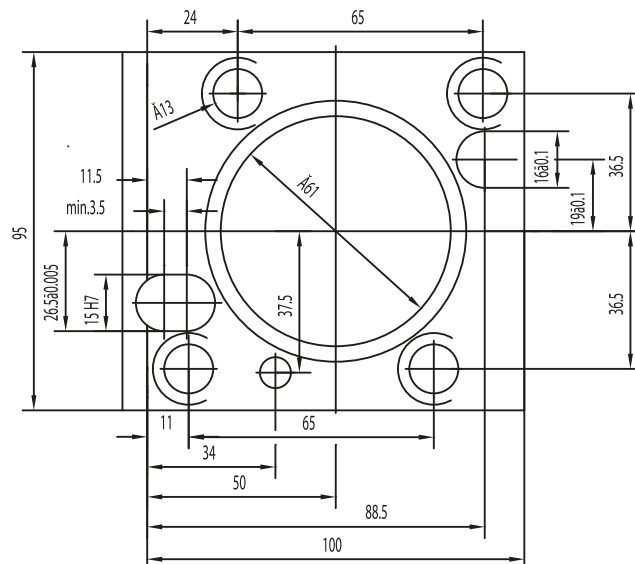

ACCESSORIES

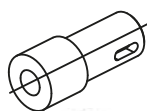
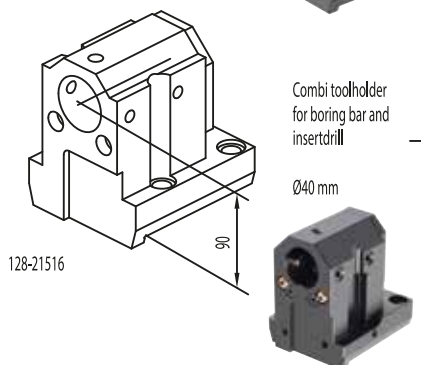
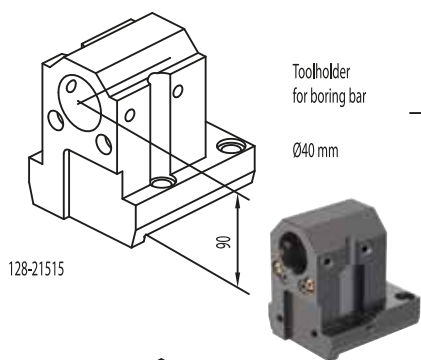

165-64011 <MT2>

165-64012 <MT3>



165-64135 (Ø8 mm)

165-64013 (Ø10 mm)

165-64014 (Ø12 mm)

165-64015 (Ø16 mm)

165-64016 (Ø20 mm)



165-64205 (Ø25 mm)

165-64206 (Ø32 mm)

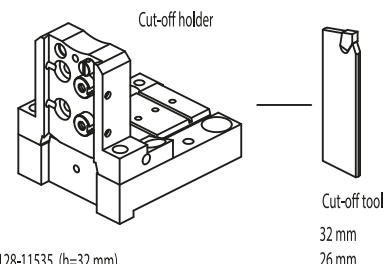

128-11535 (h=32 mm)

128-11534 (h=26 mm)

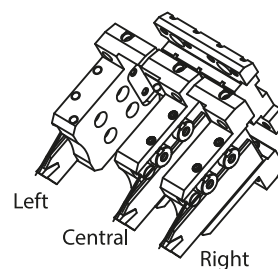

**OKUMA  
(BMT60)**

LB3000 EX (MW, MYW)

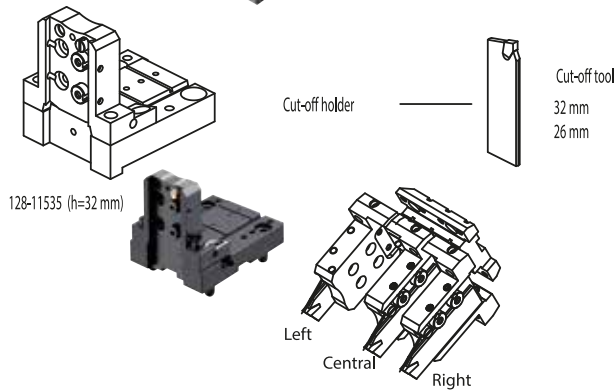
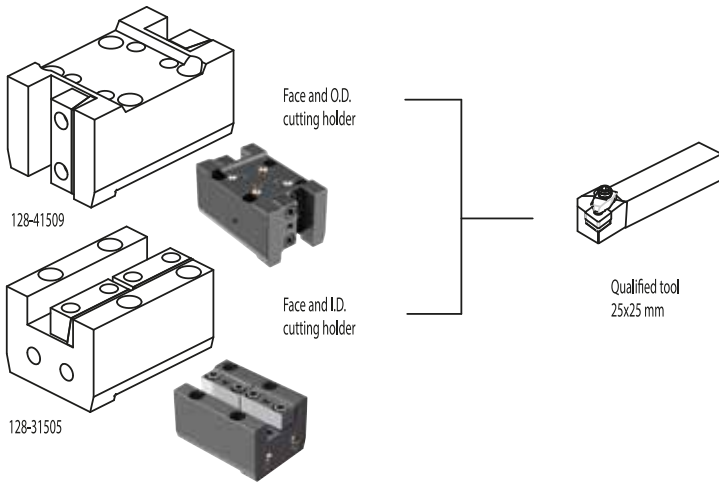

**CONNECTION**

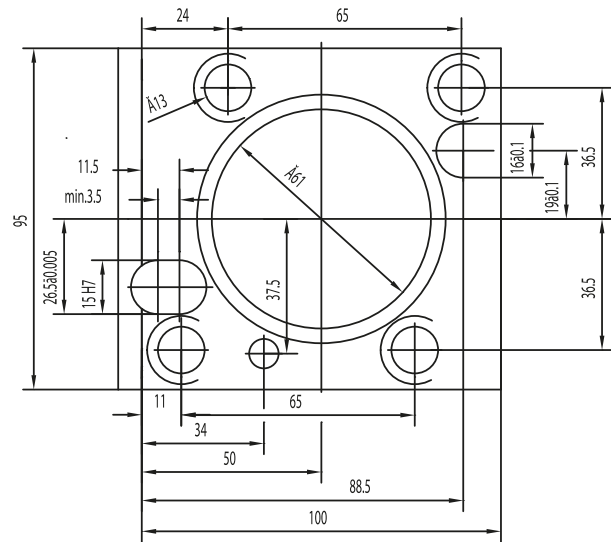

**ACCESSORIES**

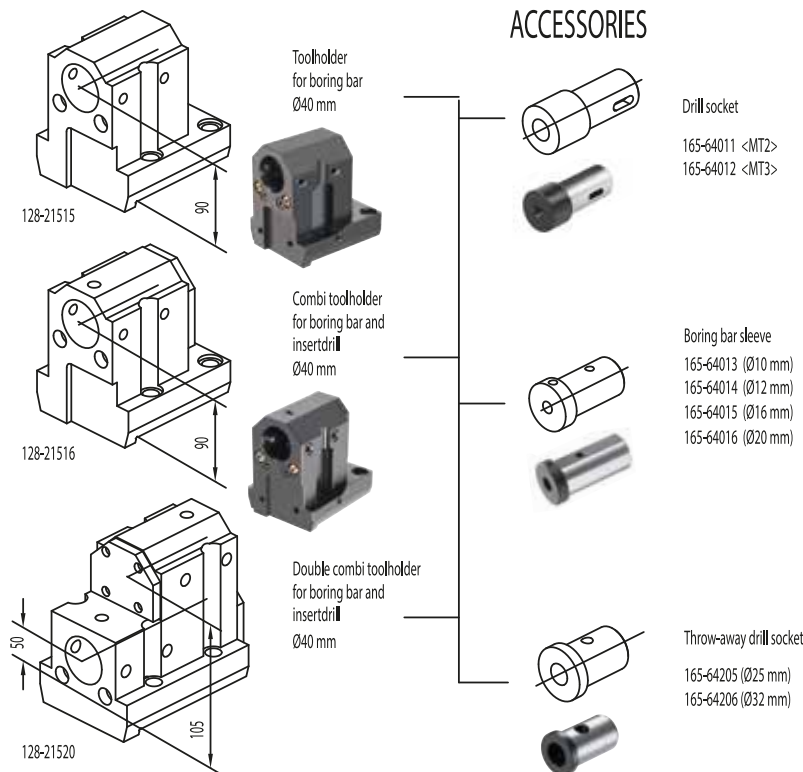

**OKUMA** LB4000 EX (M, MY)  
(BMT60)

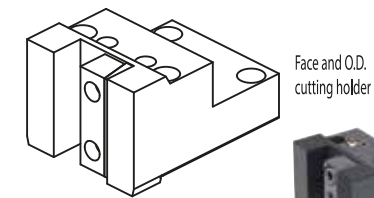

Face and O.D. cutting holder

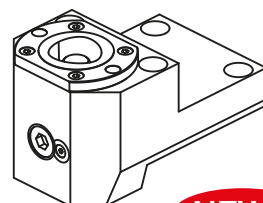
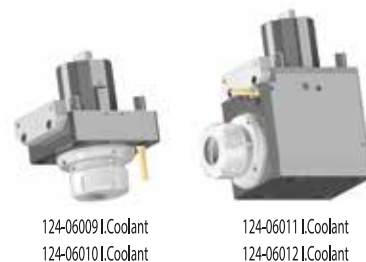
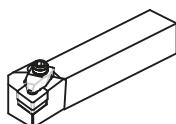

Face and O.D. cutting holder  
Polygonal

**NEWS**

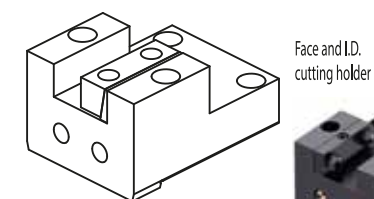

Face and I.D. cutting holder



CONNECTION

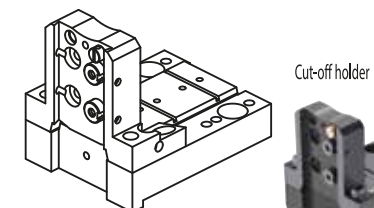
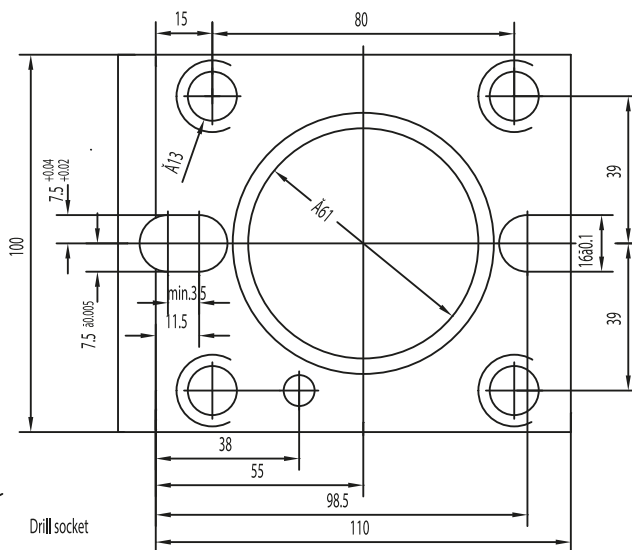

Cut-off holder



ACCESSORIES

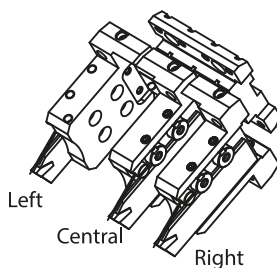

- 165-64010 <MT1>
- 165-64011 <MT2>
- 165-64012 <MT3>



- 165-64135 (Ø8 mm)
- 165-64013 (Ø10 mm)
- 165-64014 (Ø12 mm)
- 165-64015 (Ø16 mm)
- 165-64016 (Ø20 mm)

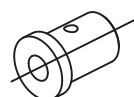
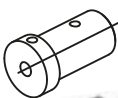

- 165-64203 (Ø16 mm)
- 165-64204 (Ø20 mm)
- 165-64205 (Ø25 mm)
- 165-64206 (Ø32 mm)

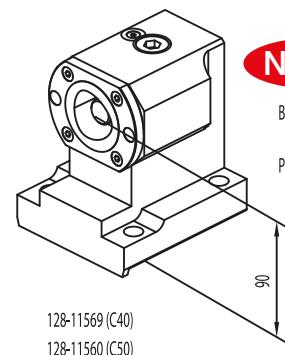

**NEWS**

Boring bar holder  
Polygonal

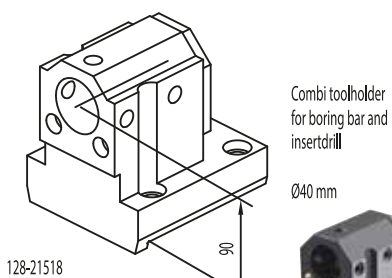

Combi toolholder for boring bar and insert drill  
Ø40 mm



**NAKAMURA TOME**  
(BMT55)

TW10

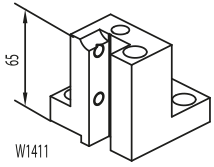

W1411

Face and O.D. cutting holder

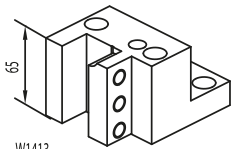

W1413

Face and O.D. cutting holder

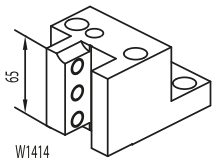

W1414

Face and O.D. cutting holder

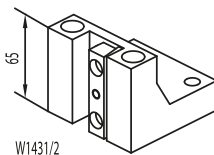

W1431/2

Face and O.D. cutting holder

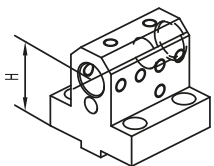

W1417 D25 (H=55 mm)  
W4437 D25 (H=75 mm)

Combi toolholder for boring bar and insert drill

Ø25 mm

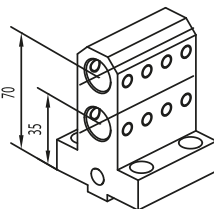

W1418 D25

Double toolholder for boring bar

Ø25 mm

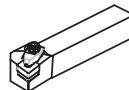

Qualified tool 20x20 mm



124-05507  
124-05508 I.Coolant



124-05509  
124-05510 I.Coolant

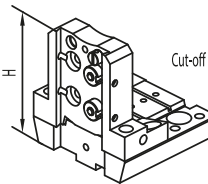

121-22076 (h=32 mm H=100 mm)



Cut-off tool

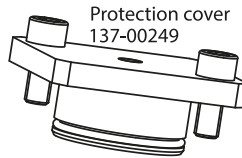
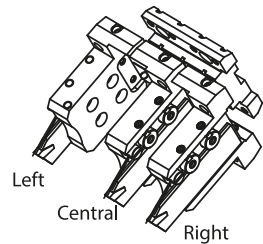

Protection cover 137-00249

**CONNECTION**

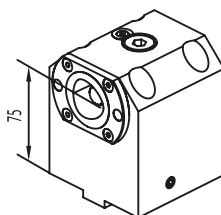
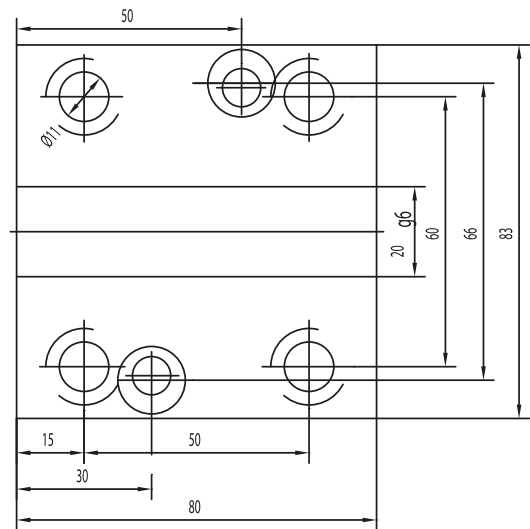

121-22098

Boring bar holder Polygonal C40

**NEWS**

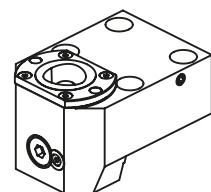

121-22099

Face and O.D. cutting holder Polygonal C40

**NEWS**



# NAKAMURA TOME (BMT65)

WT300 / SC300 / TW20  
TMC-200M / TMC-300M / SUPER NTX  
TW20M / MY / MM / MMY / MMY (12 stations)  
TW30M / MY / MM / MMY / MMY (16 stations)

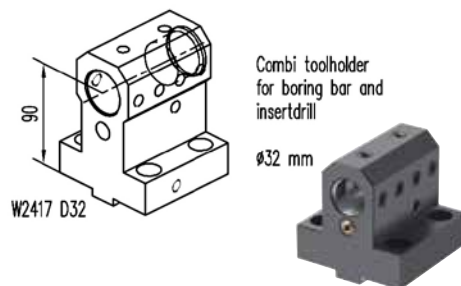
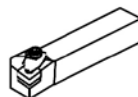
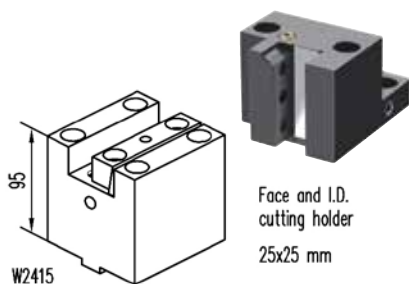
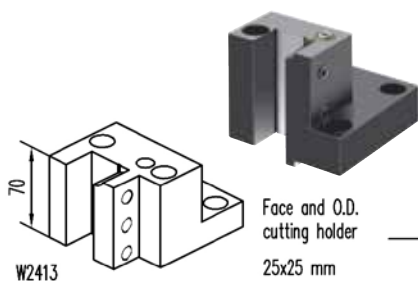
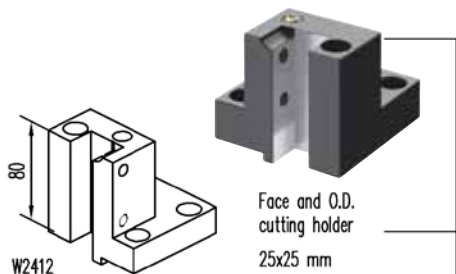

## CONNECTION

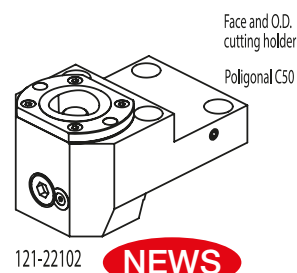
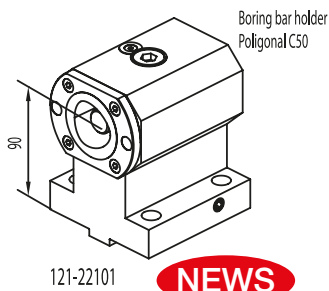
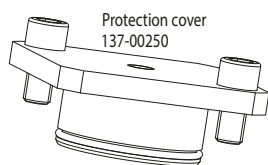
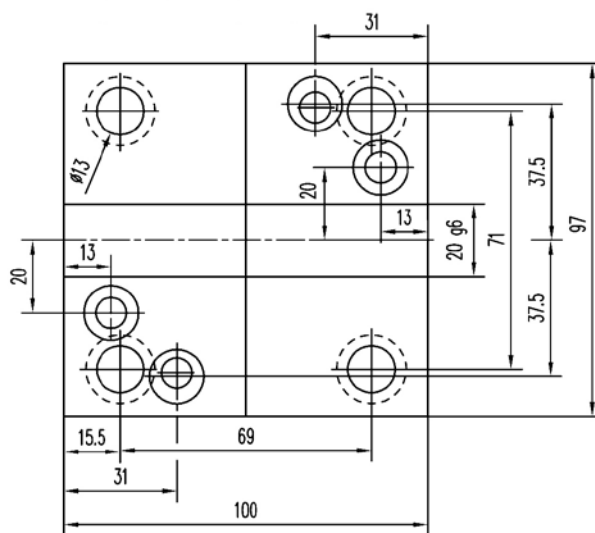

**NEWS**

**NEWS**

**NAKAMURA TOME**  
(BMT44)

NTY3/ SUPER NTMX/NTMXL / WT100  
MURATA MURATEC MT100  
WY-100II

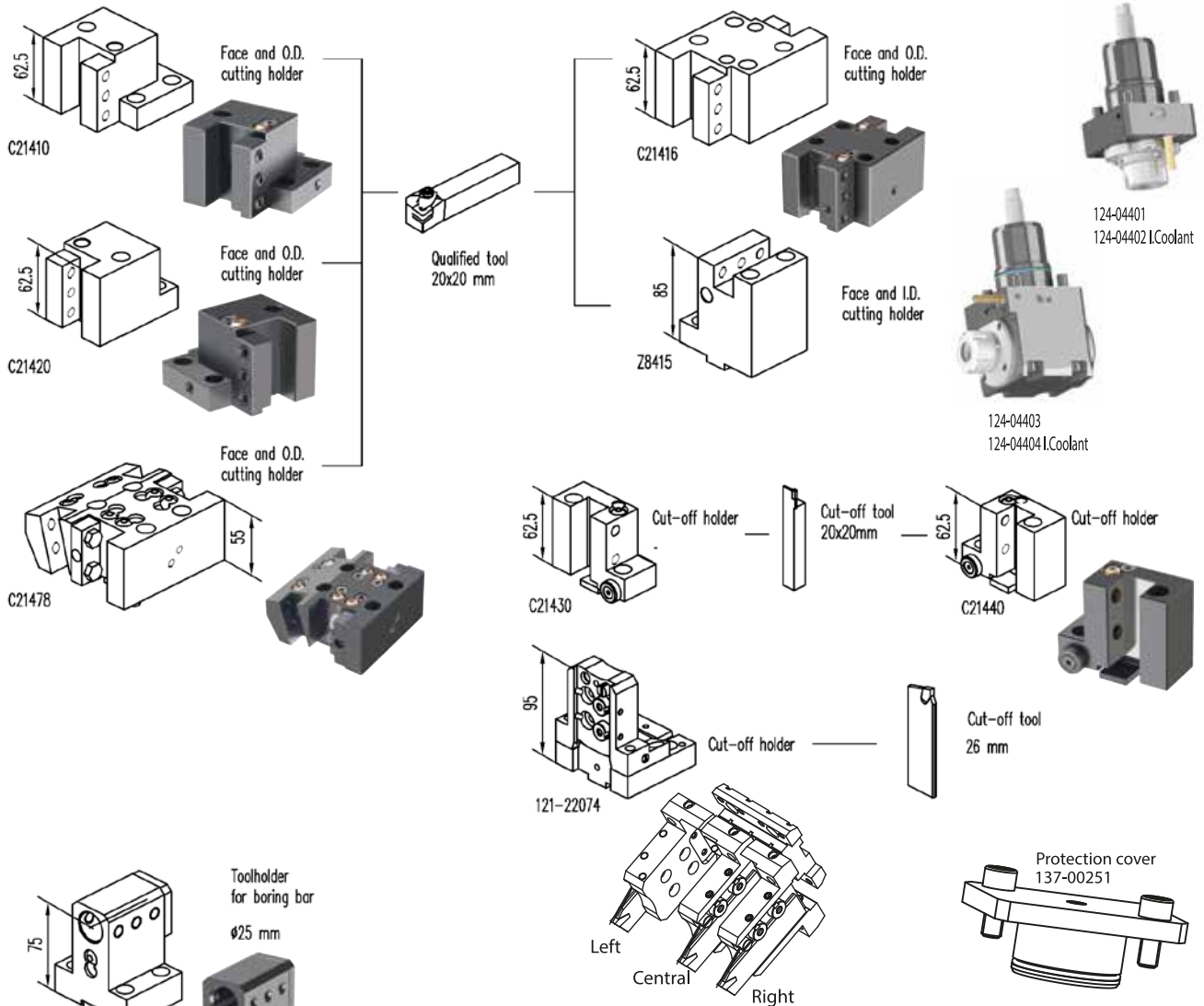

**ACCESSORIES**

**CONNECTION**

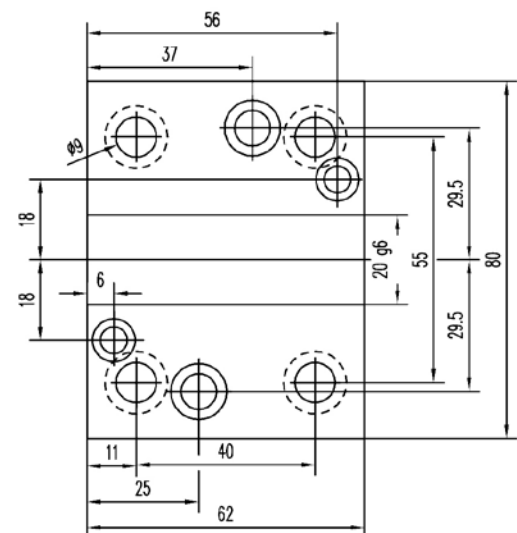
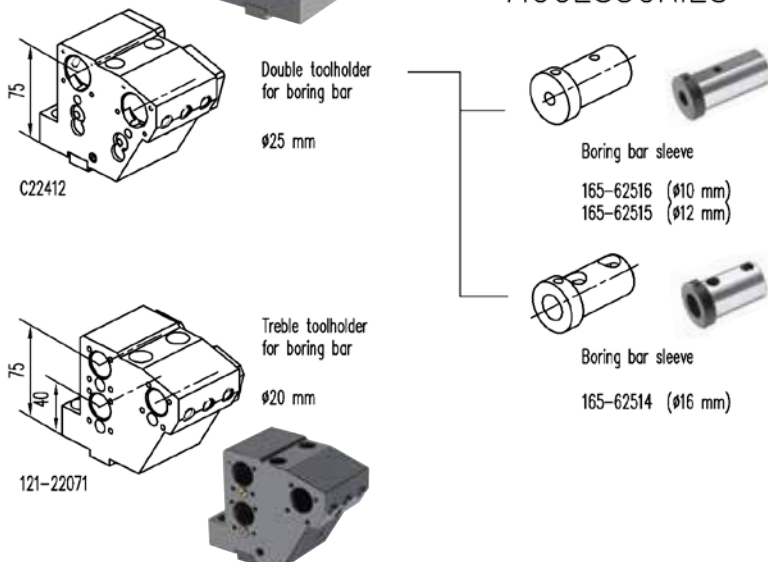

# NAKAMURA TOME (BMT55)

AS-200 / NTM 3 / NTY3-250  
 SC-150M / SC-200MY / SC-250M / SuperNTJ  
 TMC-20 II M/ML / TW-10 / TW-20  
 WT-20 II M/MY / WT150 / WT-250  
 WTS-150 / WTW-150 / WY-250  
 CMZ TX52/66

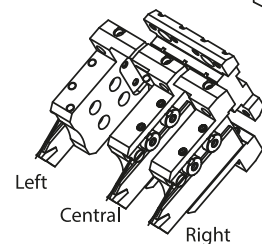
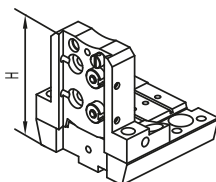
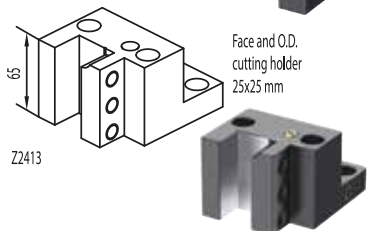
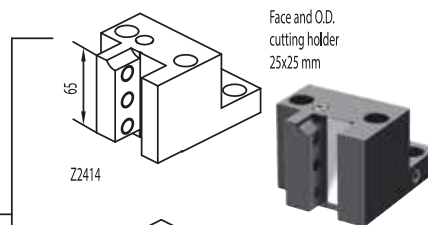
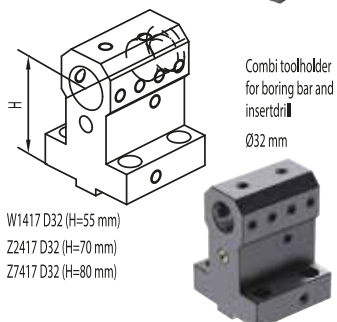
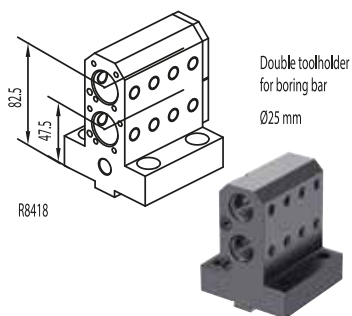
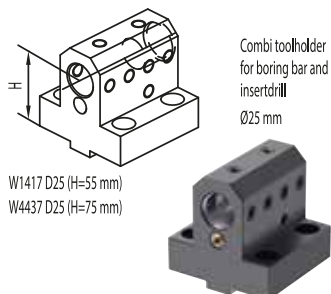
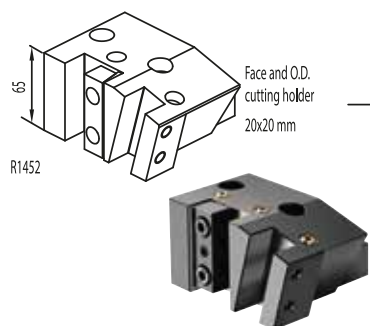
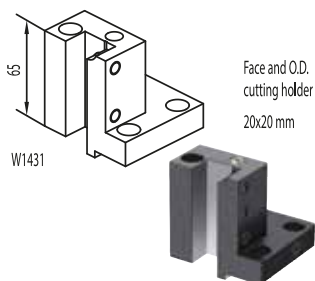

## CONNECTION

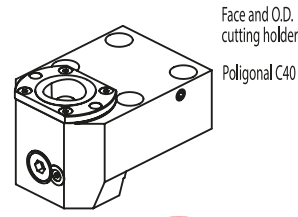
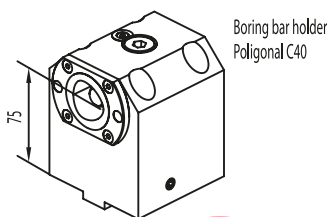
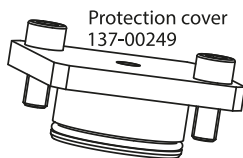
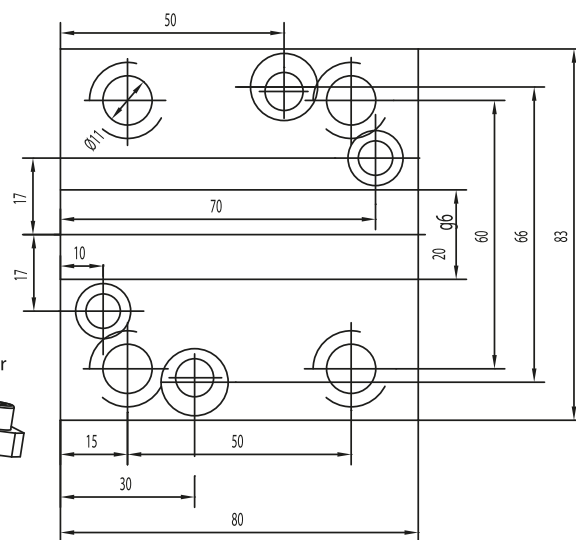

NEWS

NEWS

**DOOSAN PUMA** 230M/MS  
240M/MS

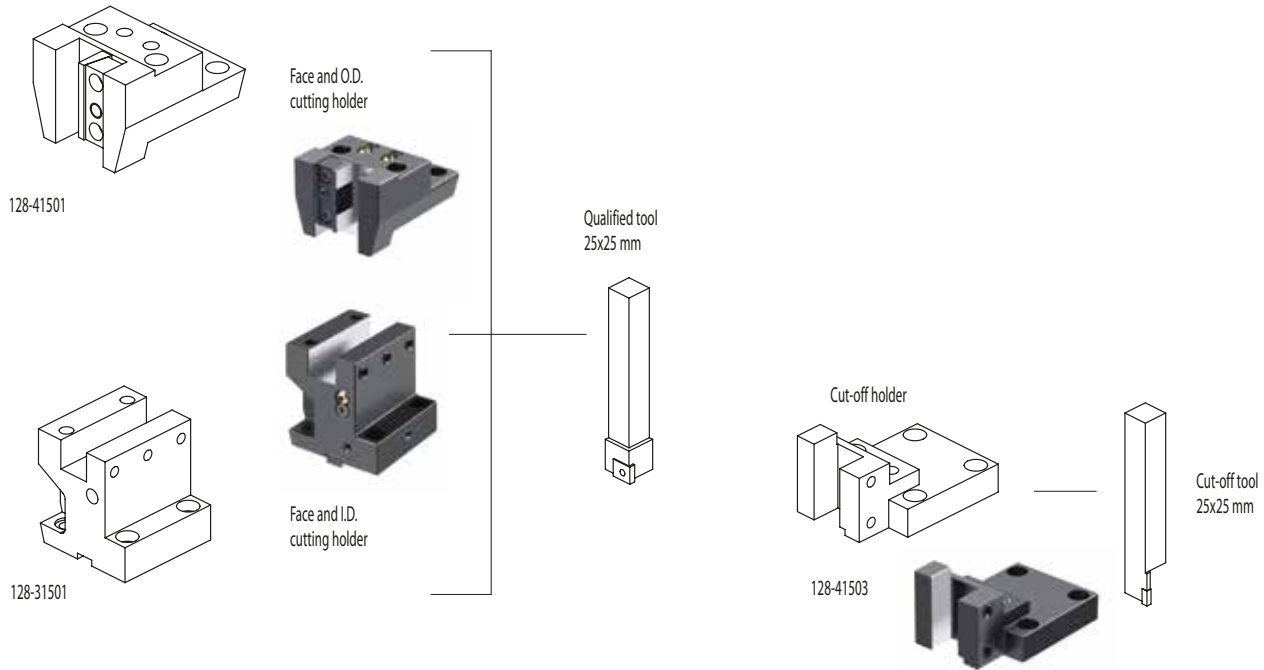

11

**ACCESSORIES**

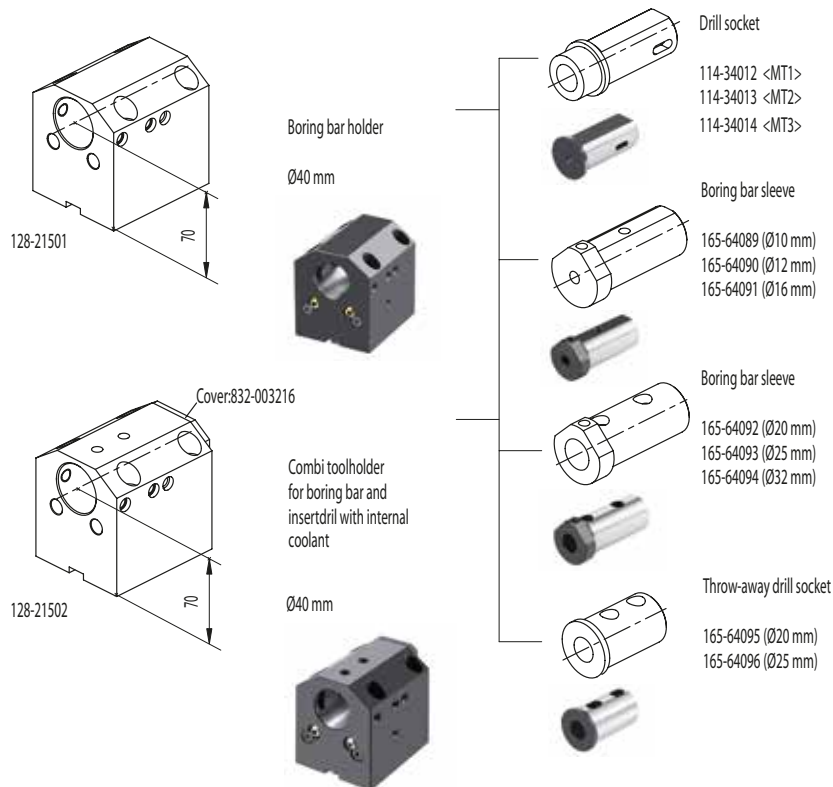

**CONNECTION**

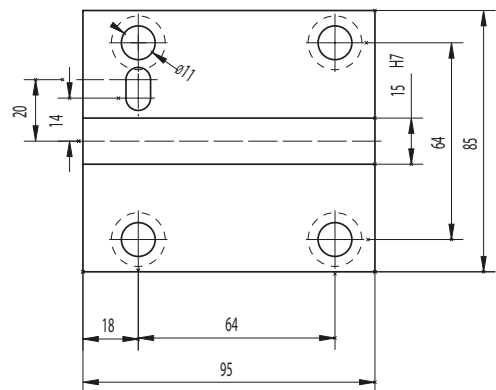

# DOOSAN PUMA

230S  
240S  
LYNX210

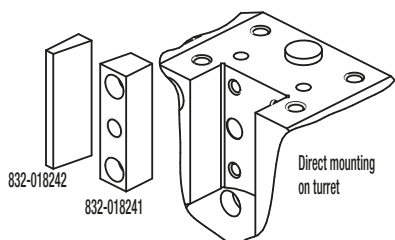

Qualified tool  
25x25 mm

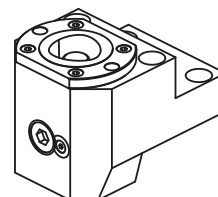
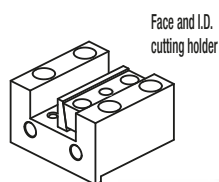

**NEWS**

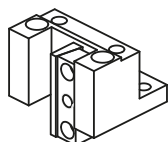

## CONNECTION

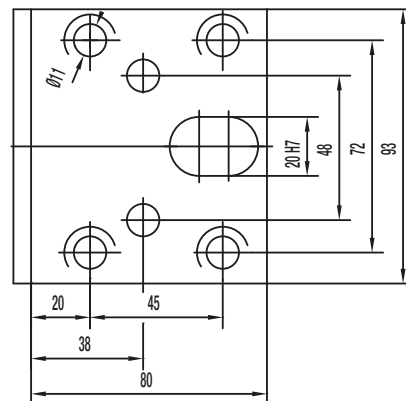

## ACCESSORIES

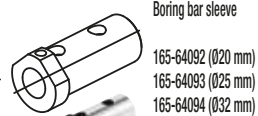
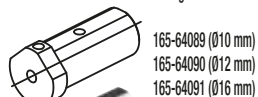
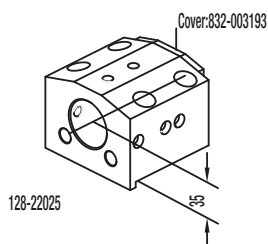
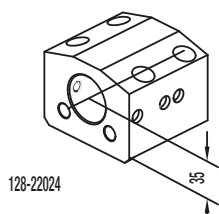



**DOOSAN**  
(BMT45)

LYNX 2100LYA/LYB (24 POSITION INDEX)  
LYNX 2100MA/220 (LMSA,LMSC)  
220 (LSYA,LSYC), 220 (M,LM)  
LYNX 220 (MA,LMA,MC,LMC)  
220 (YA,YC,LYA,LYC)  
PUMA MX1600 (T,ST)

**HARDINGE** BMT45  
**SMEC** PL1600 (M,CM)

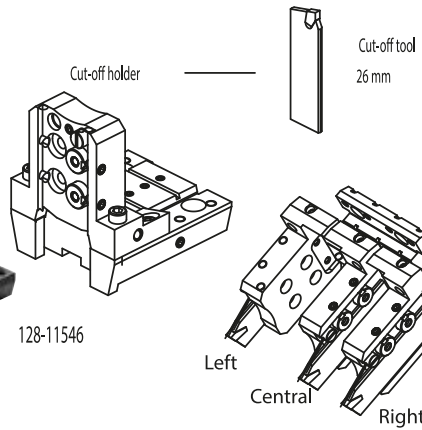
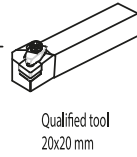
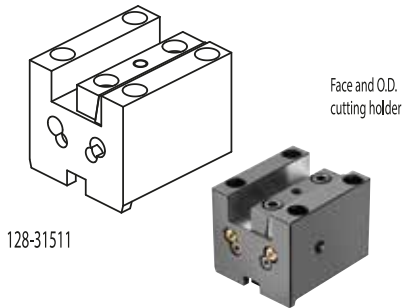
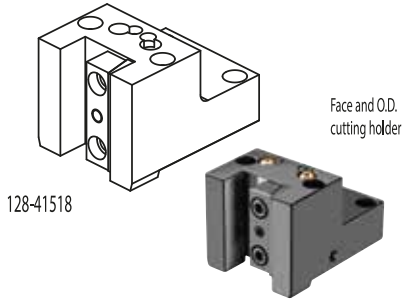

**ACCESSORIES**

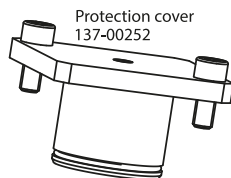
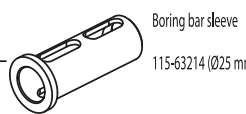
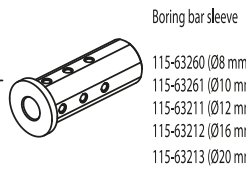
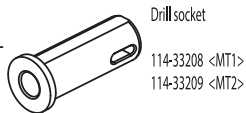
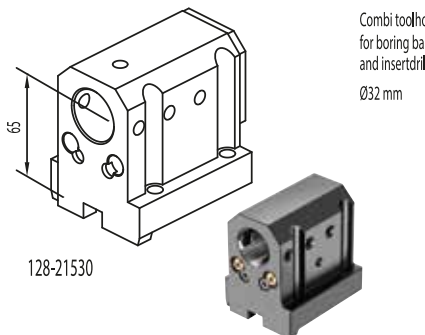
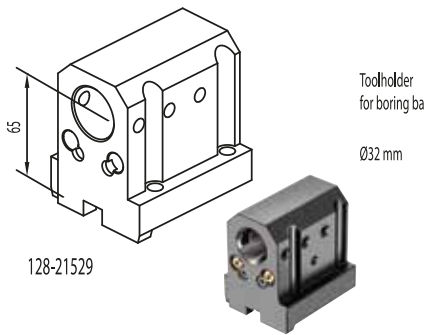

**CONNECTION**

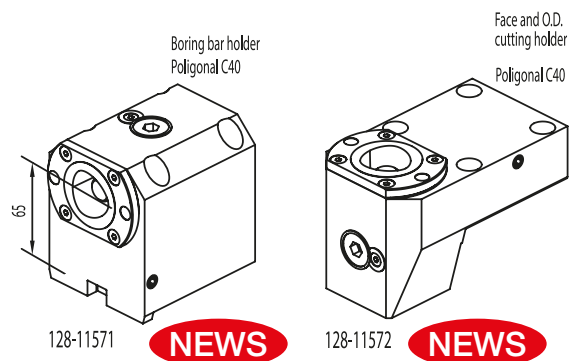
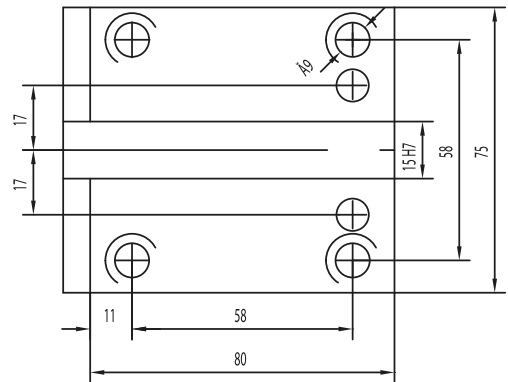

## DOOSAN (BMT55)

LYNX 300 (M)  
 PUMA 1500/2000/2500 (M,S,Y)  
 PUMA 2100 (Y,LY,SY,LSY)  
 PUMA 2100/2600/3100 M/Y/MS/SY  
 PUMA 230/240/280 (M,LM,S)  
 PUMA GT2100M / PUMA H250TM  
 PUMA MX2100 (ST/LST)  
 PUMA TL2000/2500 (M,LM)

**HARDINGE**  
**HWACHEON**  
**SMEC/SAMSUNG**  
**HYUNDAI WIA**  
**VICTOR**

BMT55  
 CUTEX-160  
 SL 20MC  
 SKT-180TTSY  
 VTURN-A16/A20 (YSCM)

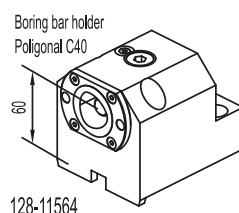
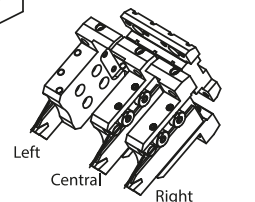
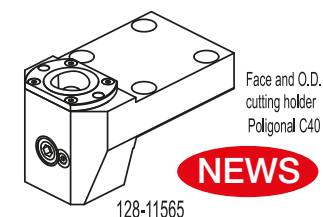
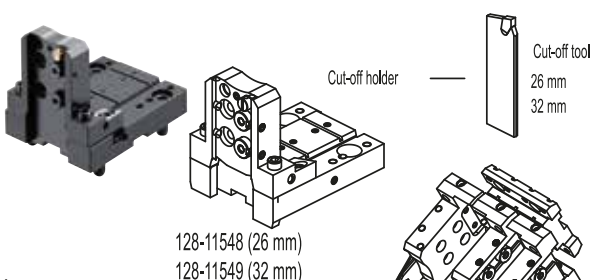
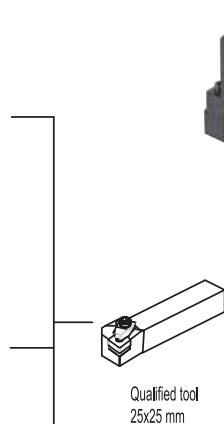
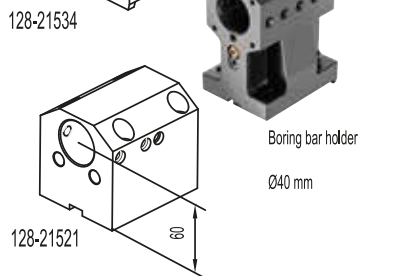
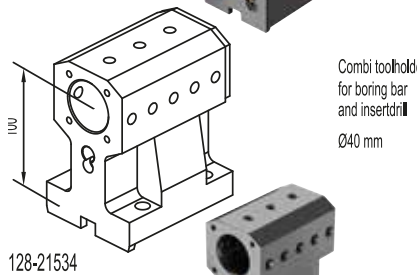
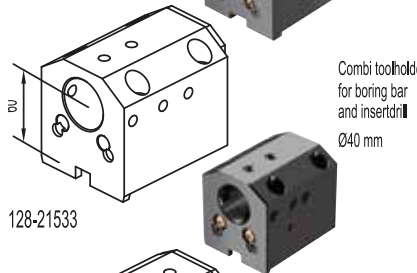
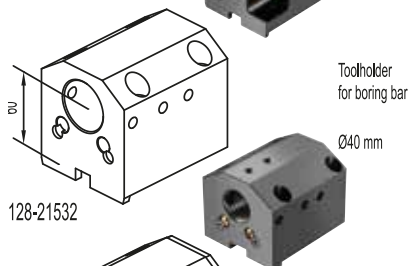
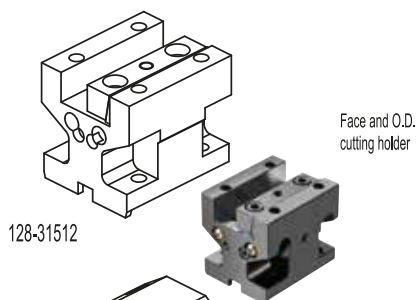
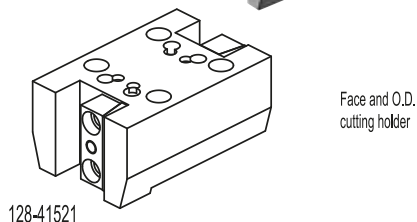
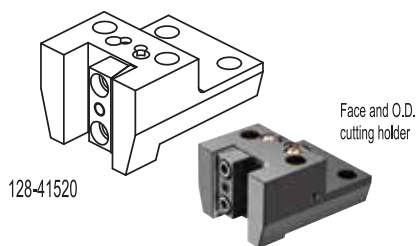

### ACCESSORIES

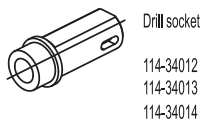

114-34012 <MT1>  
 114-34013 <MT2>  
 114-34014 <MT3>

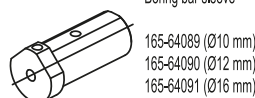

165-64089 (Ø10 mm)  
 165-64090 (Ø12 mm)  
 165-64091 (Ø16 mm)

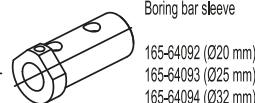

165-64092 (Ø20 mm)  
 165-64093 (Ø25 mm)  
 165-64094 (Ø32 mm)

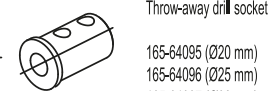

165-64095 (Ø20 mm)  
 165-64096 (Ø25 mm)  
 165-64097 (Ø32 mm)

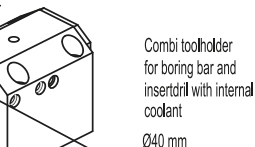

**NEWS**

### Driven tools

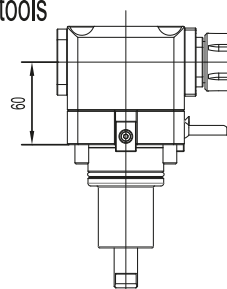
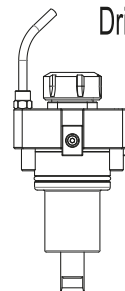

124-06509 i.coolant

124-06510 i.coolant



### CONNECTION

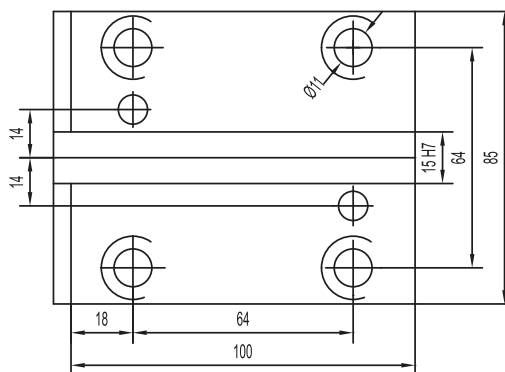

## DOOSAN PUMA (BMT65)

PUMA 2100/2600 (M,LM,MS,LMS)  
 PUMA 2100/2600 (Y,LY,SY,LSY)  
 PUMA 300 (M,MS,MB,MC)  
 PUMA 3100 (M,LM,LY,XLM,XLY,ULM,ULY)  
 PUMA MX2000/2500  
 PUMA MX2600 (T,ST)  
 PUMA TT2500 (MS/SY)  
 PUMA V400 (M)  
 PUMA VT450 (M,2SP)

**HWACHEON**  
 CUTEX-240  
 HI-TECH200/T2-Series  
 HI-TECH300/400  
 VT-450  
**HYUNDAI WIA**  
 L2100SY  
 SKT-200/250TTSY  
 SKT-250/300 (L,M)  
 SKT-250/300 (MS)

**MAXSIN**  
 BMT65  
**SMEC/SAMSUNG**  
 SL25 / SL35  
**TONGTAI**  
 TMT2000  
**VICTOR**  
 VTURN-A26 (YSCM)  
**HAAS**  
 ST-20 - ST-25 - ST-30  
 ST-35 - DS-30Y  
 ST-20Y - ST-25Y - ST-30Y - ST-35Y

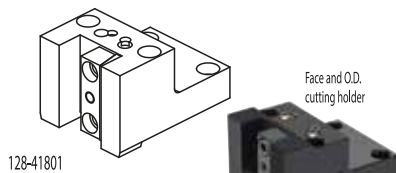

Face and O.D. cutting holder

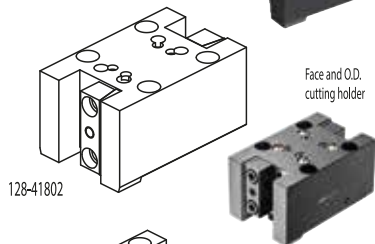

Face and O.D. cutting holder

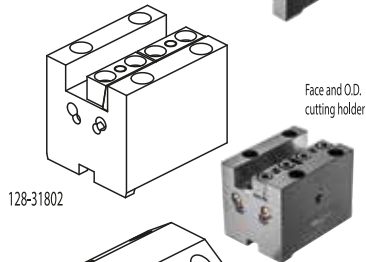

Face and O.D. cutting holder

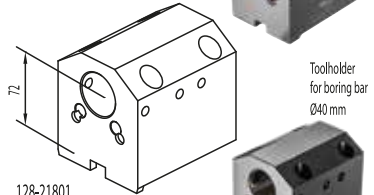

Toolholder for boring bar Ø40 mm

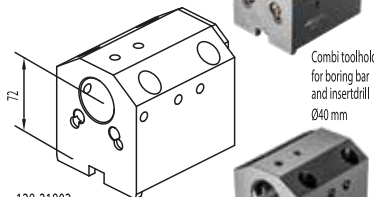

Combi toolholder for boring bar and insert drill Ø40 mm

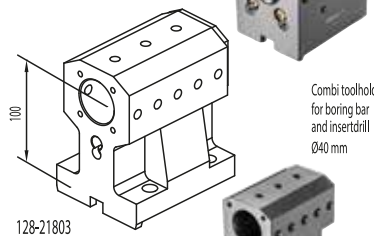

Combi toolholder for boring bar and insert drill Ø40 mm

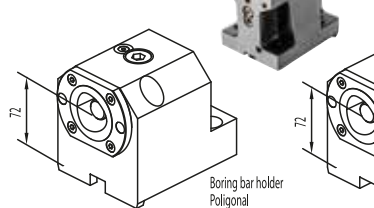

Boring bar holder Polygonal

**NEWS**

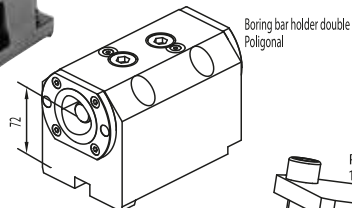

Boring bar holder double Polygonal

**NEWS**

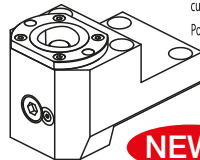
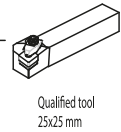

**NEWS**

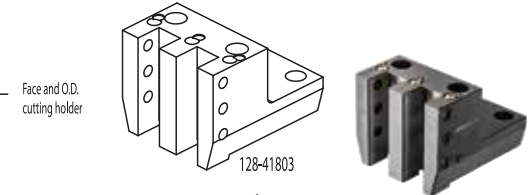

Face and O.D. cutting holder

Face and O.D. cutting holder

Face and O.D. cutting holder Polygonal

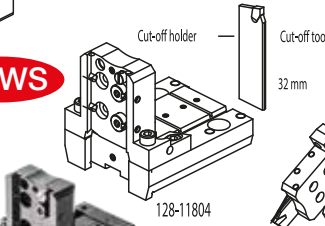

Cut-off holder

Cut-off tool 32 mm

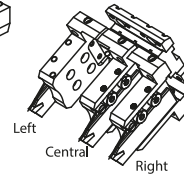
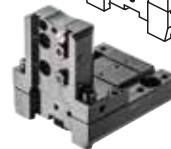

### ACCESSORIES

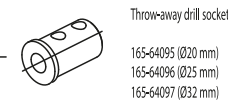
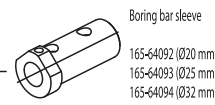
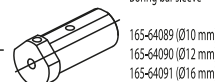
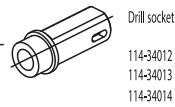

### Driven tools

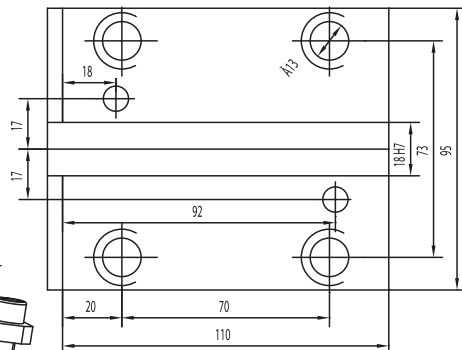
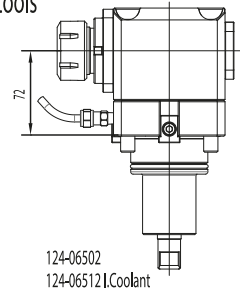
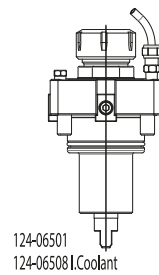

# DOOSAN PUMA 400 (BMT75) 480M/LM/XLM VT 750M/TM

## CONNECTION

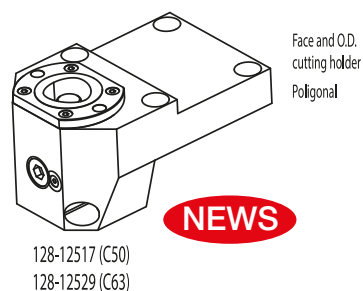
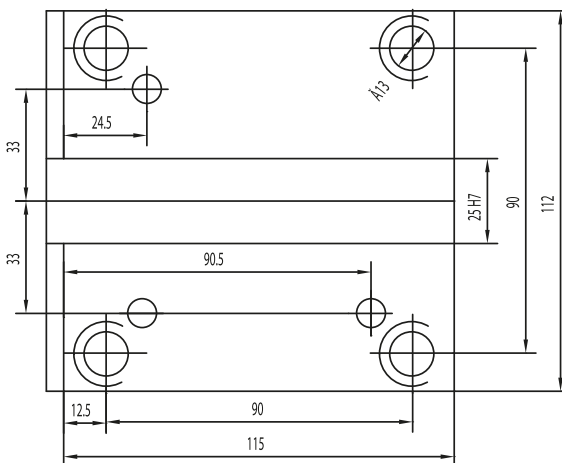
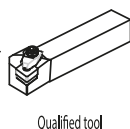
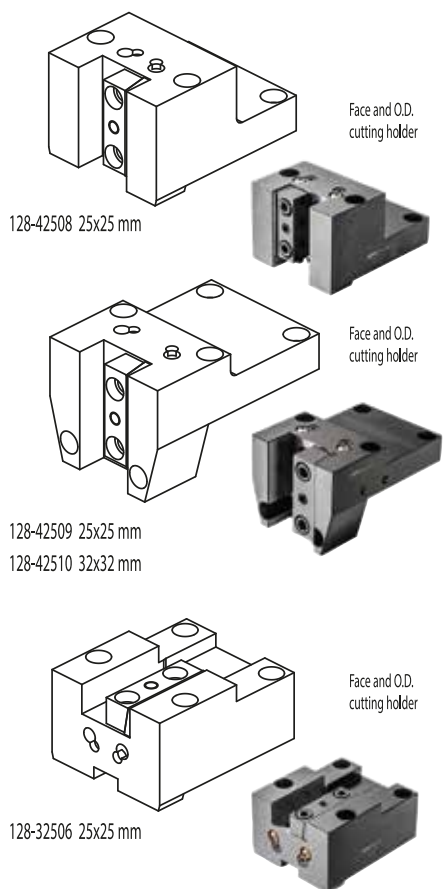

## ACCESSORIES

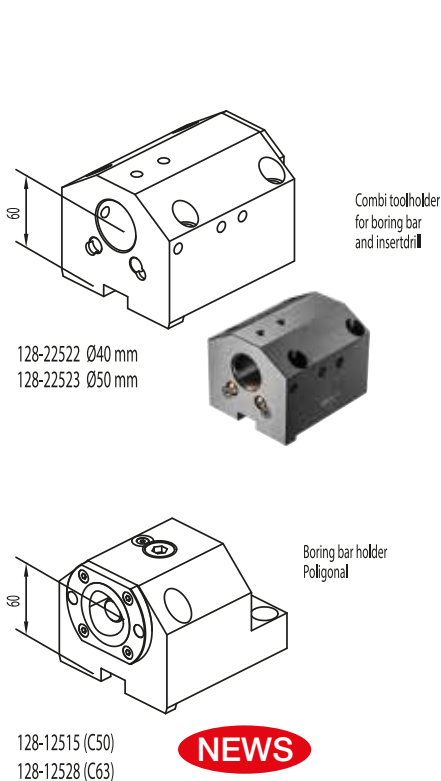

- Drill socket Ø40  
114-34012 <MT1>  
114-34013 <MT2>  
114-34014 <MT3>
- Boring bar sleeve Ø40  
165-64089 (Ø10 mm)  
165-64090 (Ø12 mm)  
165-64091 (Ø16 mm)
- Boring bar sleeve Ø40  
165-64092 (Ø20 mm)  
165-64093 (Ø25 mm)  
165-64094 (Ø32 mm)
- Throw-away drill socket Ø40  
165-64095 (Ø20 mm)  
165-64096 (Ø25 mm)  
165-64097 (Ø32 mm)

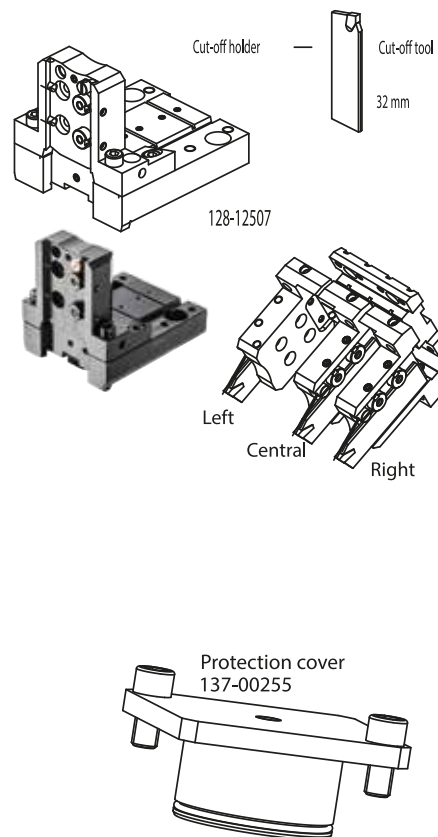

**DOOSAN PUMA  
(BMT85)**

600M/LM  
700M/LM  
800M/LM  
VT900M/TM  
VT1100M

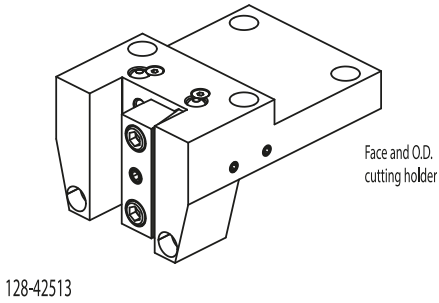

Face and O.D. cutting holder

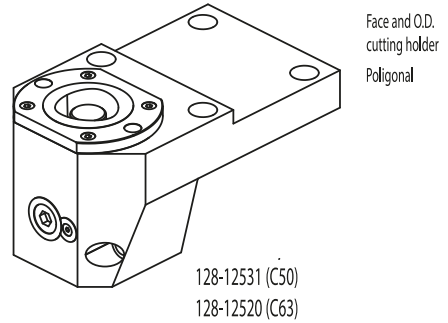

Face and O.D. cutting holder  
Polygonal

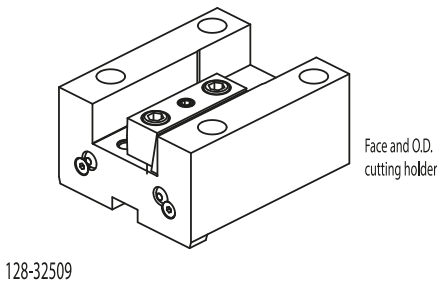

Face and O.D. cutting holder

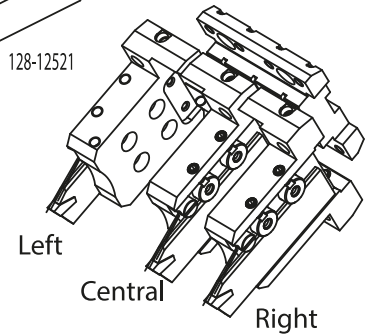
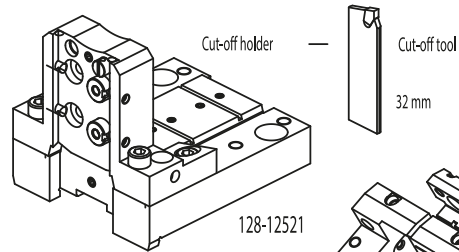
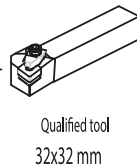

**CONNECTION**

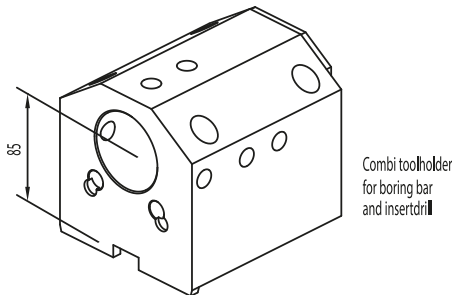

Combi toolholder for boring bar and insert drilling

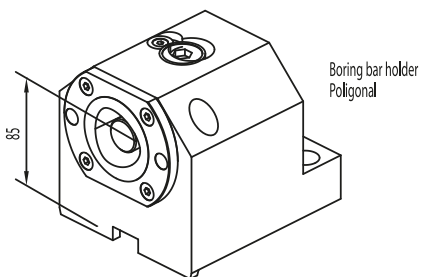
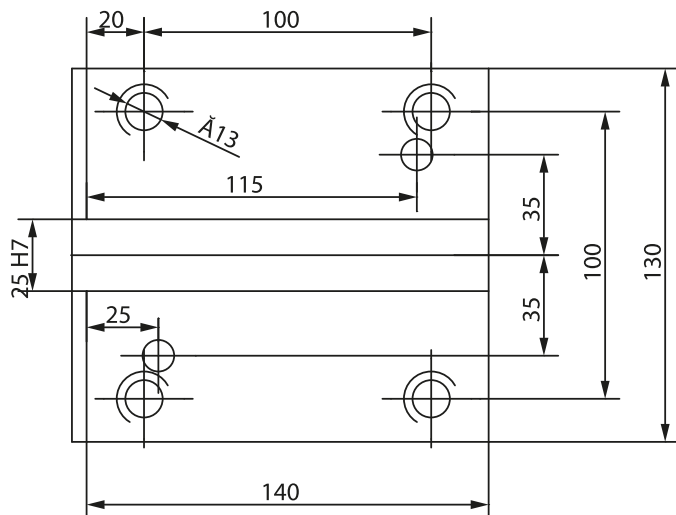

Boring bar holder  
Polygonal

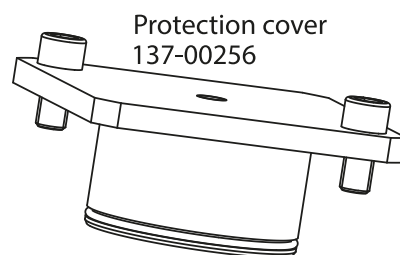



# MAZAK NEXUS SQT100/150

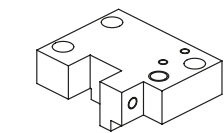

123-33801

Face and O.D. cutting holder

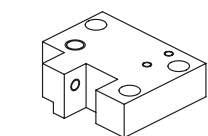

123-33802

Face and O.D. cutting holder



Qualified tool  
20x20 mm

## CONNECTION

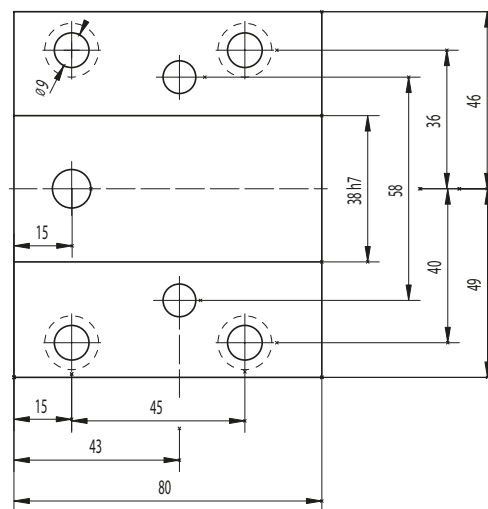

## ACCESSORIES

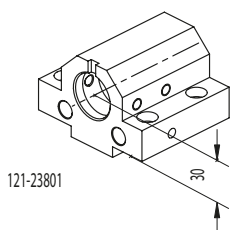

121-23801

Boring bar holder

Ø32 mm

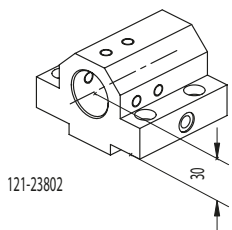

121-23802

Toolholder for insertdrill with internal coolant

Ø32 mm

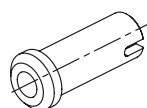

Drill socket  
114-33216 <MT2>



Boring bar sleeve  
165-63241 (Ø8 mm)  
165-63242 (Ø10 mm)  
165-63243 (Ø12 mm)  
165-63244 (Ø16 mm)

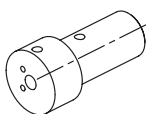

Boring bar sleeve  
165-63245 (Ø20 mm)  
165-63246 (Ø25 mm)

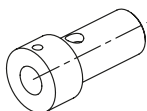

**MAZAK NEXUS** QTN200/250

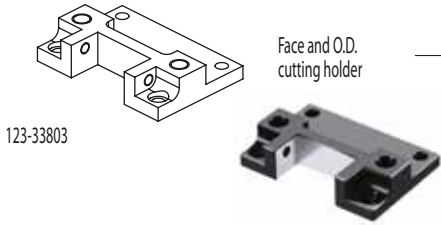

Face and O.D. cutting holder

123-33803



Qualified tool  
25x25 mm

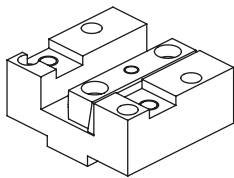

Face and I.D. cutting holder

122-13802

**CONNECTION**

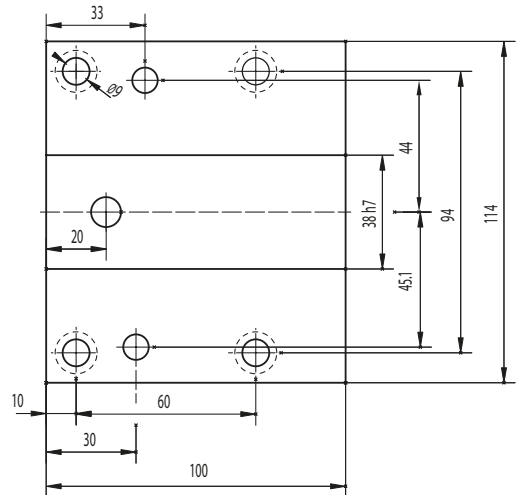

**ACCESSORIES**

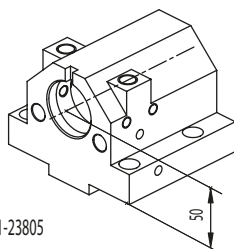

Boring bar holder  
Ø40 mm

121-23805

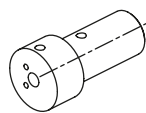

Boring bar sleeve

- 165-64114 (Ø8 mm)
- 165-64115 (Ø10 mm)
- 165-64116 (Ø12 mm)
- 165-64117 (Ø16 mm)
- 165-64118 (Ø20 mm)

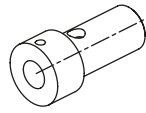

Boring bar sleeve

- 165-64119 (Ø25 mm)
- 165-64120 (Ø32 mm)

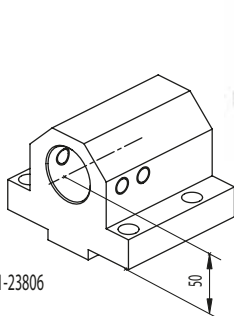

Toolholder for insertdrill with internal coolant  
Ø40 mm

121-23806

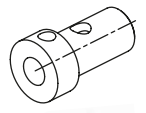

Throw-away drill socket

- 165-64121 (Ø20 mm)
- 165-64122 (Ø25 mm)
- 165-64123 (Ø32 mm)



# MAZAK SQT

SQT 15, SQT 18 M / MS - 12 Stations  
SQT 200, SQT 250 M / MS - 12 Stations

# MAZAK QTN (VDI40)

QTN 200, QTN 250 M / MB / MS / MY / MSY - 12 Stations

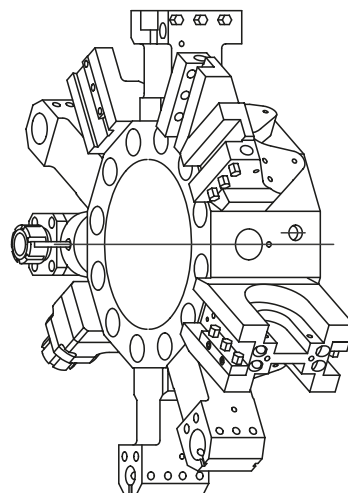
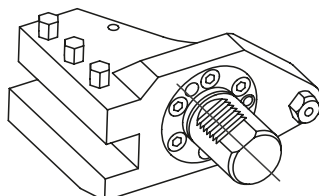
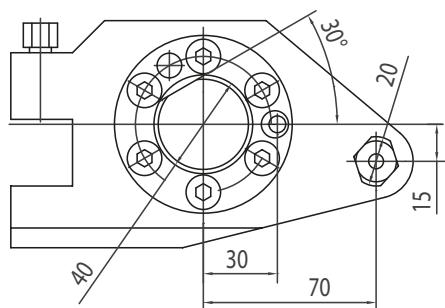

Qualified tool  
25x25 mm

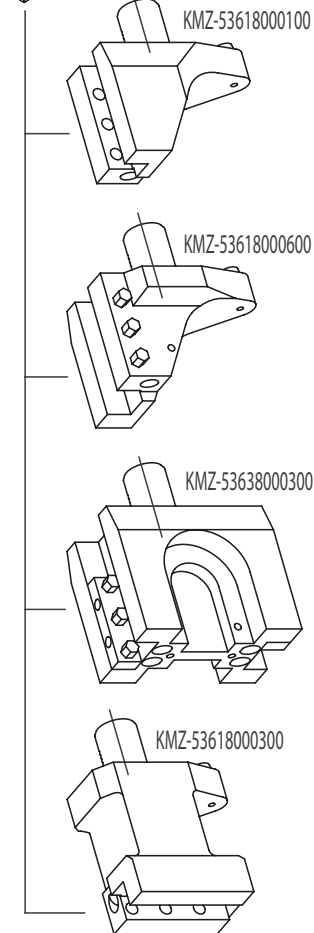

## ACCESSORIES

Drill socket  
114-34015 <MT1>  
114-34016 <MT2>  
114-34017 <MT3>



Boring bar sleeve  
165-64114 (Ø8 mm)  
165-64115 (Ø10 mm)  
165-64116 (Ø12 mm)  
165-64117 (Ø16 mm)  
165-64118 (Ø20 mm)



Boring bar sleeve  
165-64119 (Ø25 mm)  
165-64120 (Ø32 mm)



Throw-away drill socket  
165-64121 (Ø20 mm)  
165-64122 (Ø25 mm)  
165-64123 (Ø32 mm)



Cut-off tool  
32 mm

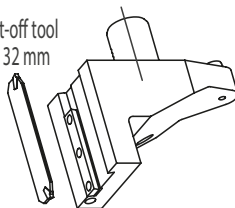

KMZ-53618000400

KMZ-53208005100

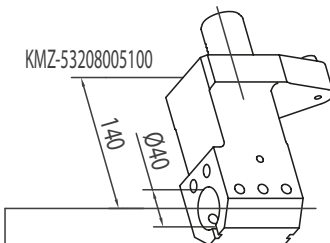

KMZ-53638000400

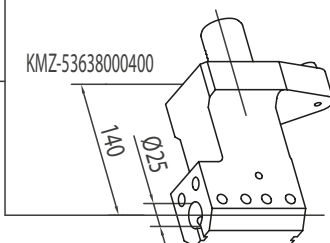

KMZ-53208005200

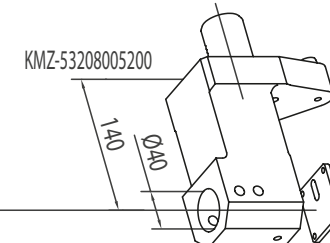

ER32 COLLET

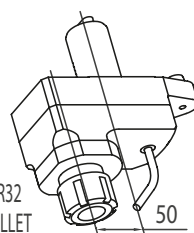

116-54019

ER32 COLLET

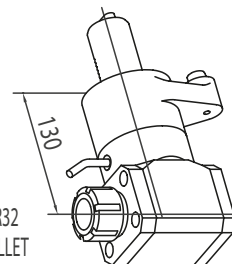

116-54020



**HAAS**  
 SL20 - SL30  
 ST-20 - ST-25  
 ST-30 - ST-35  
 DS-30

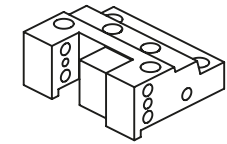

128-42011

Face and O.D. cutting holder

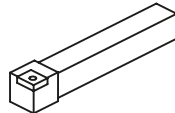

Qualified tool  
25x25 mm

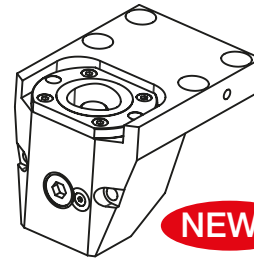

128-12059

Face and O.D. cutting holder  
 Poligonal C50

**NEWS**

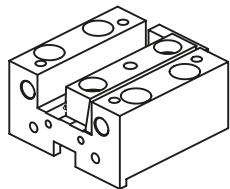

128-32001

Face and I.D. cutting holder



**CONNECTION**

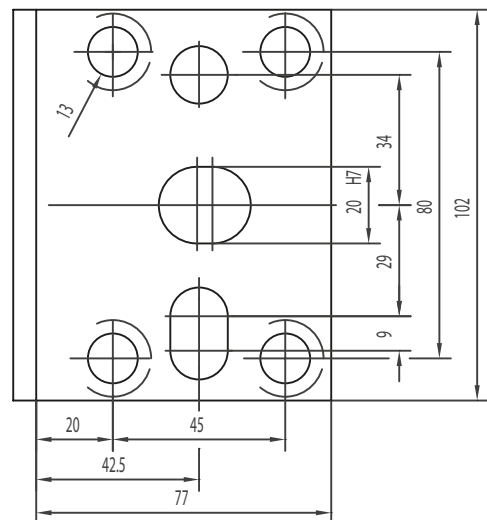

**ACCESSORIES**

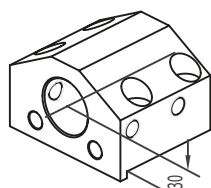

128-22001

Toolholder for boring bar



Ø40 mm

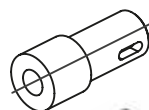

Drill socket

- 165-64010 <MT1>
- 165-64011 <MT2>
- 165-64012 <MT3>



Boring bar sleeve and throw-away drill socket

- 165-64135 (Ø8 mm)
- 165-64013 (Ø10 mm)
- 165-64014 (Ø12 mm)
- 165-64015 (Ø16 mm)
- 165-64016 (Ø20 mm)

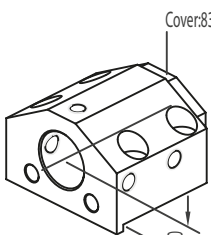

128-22005

Combi toolholder for boring bar and insertdrill with internal coolant



Ø40 mm



Boring bar sleeve and throw-away drill socket

- 165-64017 (Ø25 mm)
- 165-64018 (Ø32 mm)

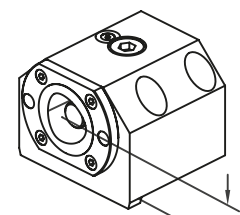

128-12057

Boring bar holder  
 Poligonal C50

**NEWS**

## HAAS (BMT65)

- ST-20
- ST-25
- ST-30
- ST-35
- DS-30

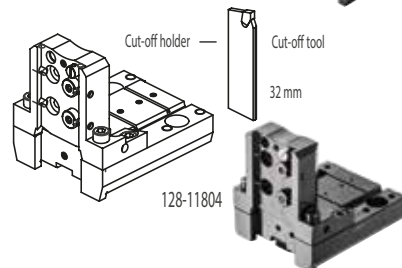
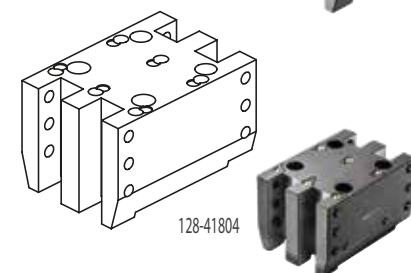
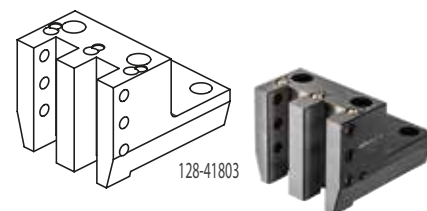
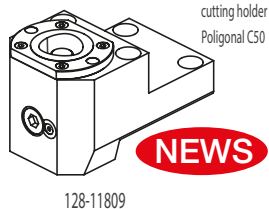
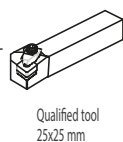
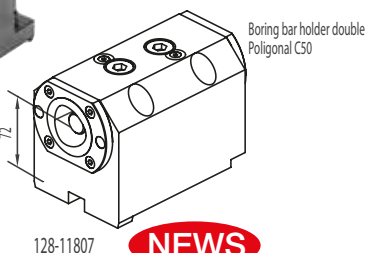
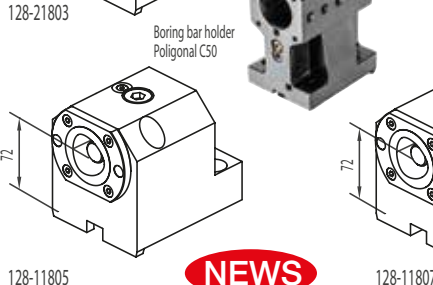
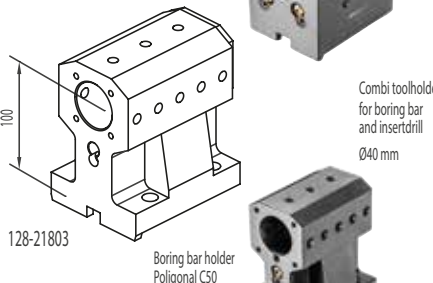
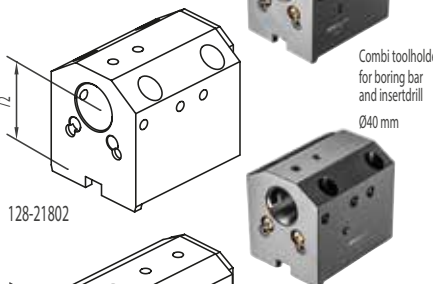
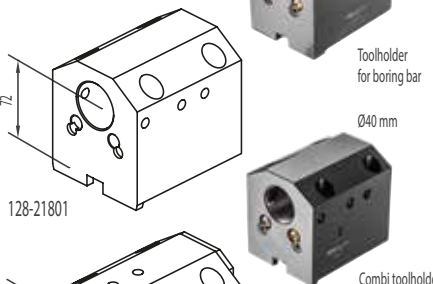
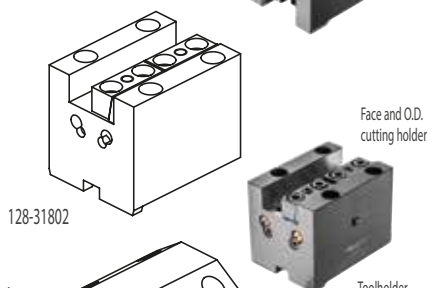
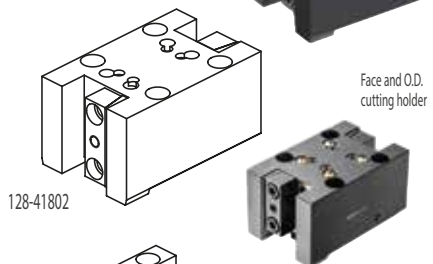
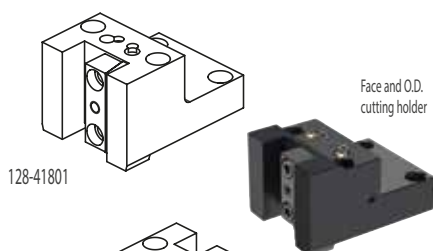

### ACCESSORIES

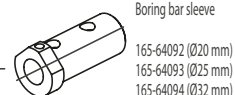
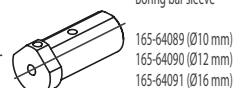
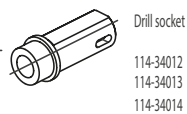

### Driven tools

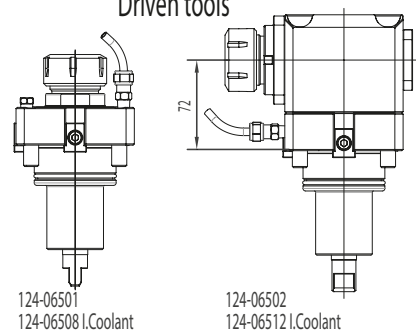

### CONNECTION

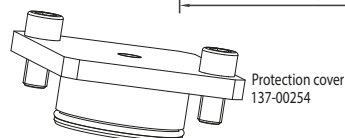
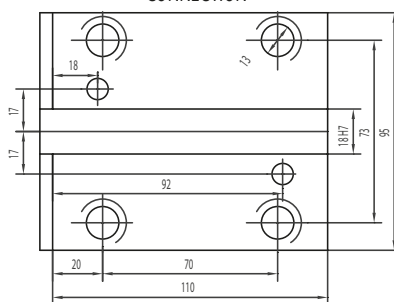



**WFL**  
**(HSK100)** MILLTURN 120

**ICTM STANDARD**



H100APCLNL/R16



H100APDJNL/R15

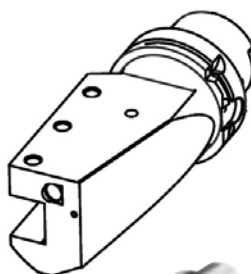

Axial toolholder long

- 142-21604 (25x25 mm, left)
- 142-11603 (25x25 mm, right)
- 142-21603 (32x32 mm, left)
- 142-11604 (32x32 mm, right)

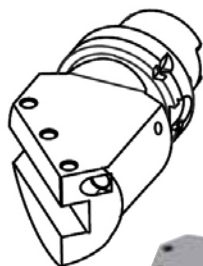

Toolholder 45°  
25x25 mm  
141-11601



# GOODWAY (BMT60)

GS2000 SERIES  
GS3000 SERIES  
GS4000 SERIES

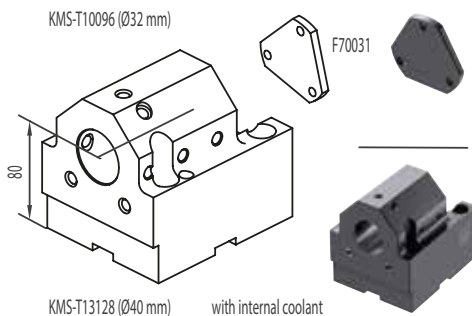
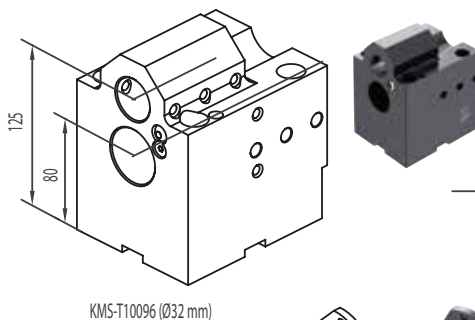
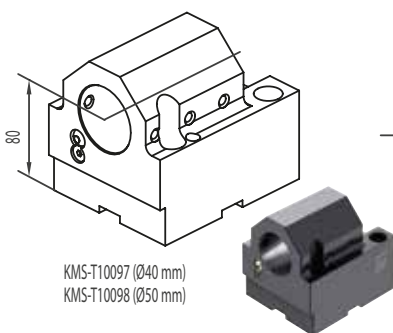
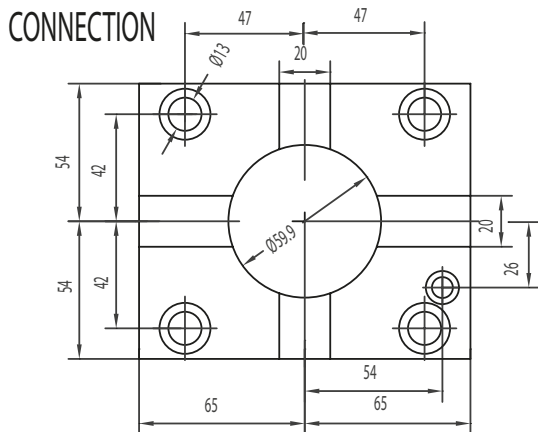
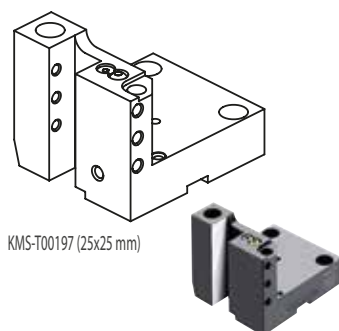
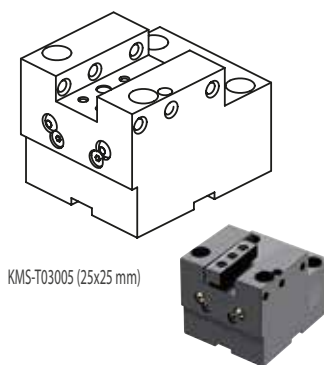
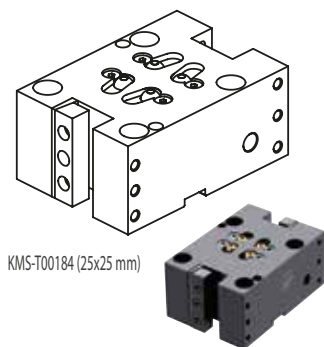
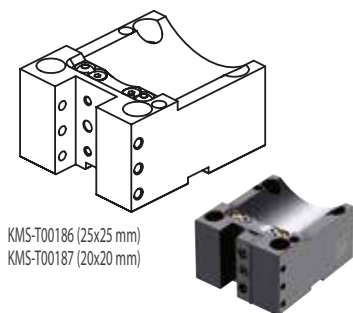
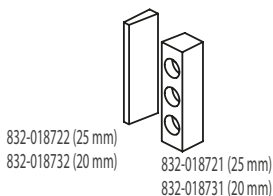

## Driven tools

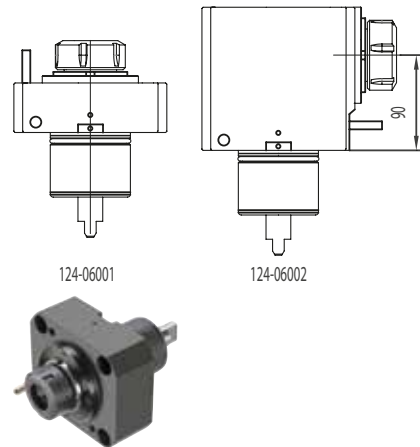

## ACCESSORIES

- KMS-T20098-A (Ø32 mm)
- KMS-T20096-A (Ø25 mm)
- KMS-T20094-A (Ø20 mm)
- KMS-T20092-A (Ø16 mm)
- KMS-T20090-A (Ø12 mm)
- KMS-T20088-A (Ø10 mm)
- KMS-T20086-A (Ø8 mm)

- KMS-T20196-A (Ø20 mm)
- KMS-T20194-A (Ø16 mm)
- KMS-T20110-A (Ø12 mm)
- KMS-T20108-A (Ø10 mm)
- KMS-T20106-A (Ø8 mm)

- KMS-T22042-A (MT3)
- KMS-T22044-A (MT4)
- KMS-T22046-A (MT2)
- KMS-T22066-A (MT1)

- KMS-T20122-A (Ø25 mm)
- KMS-T20120-A (Ø20 mm)
- KMS-T20118-A (Ø16 mm)
- KMS-T20116-A (Ø12 mm)
- KMS-T20114-A (Ø10 mm)
- KMS-T20112-A (Ø8 mm)

- KMS-T20100-A (Ø32 mm)
- KMS-T20102-A (Ø25 mm)
- KMS-T20104-A (Ø20 mm)
- KMS-T20190-A (Ø16 mm)