

***WERKZEUGAUFNAHMEN  
DIN 69893 | ISO 12164 (HSK)***

***TOOLHOLDERS  
DIN 69893 | ISO 12164 (HSK)***

***PORTE-OUTILS  
DIN 69893 | ISO 12164 (HSK)***

# ***DIN 69893 HSK***

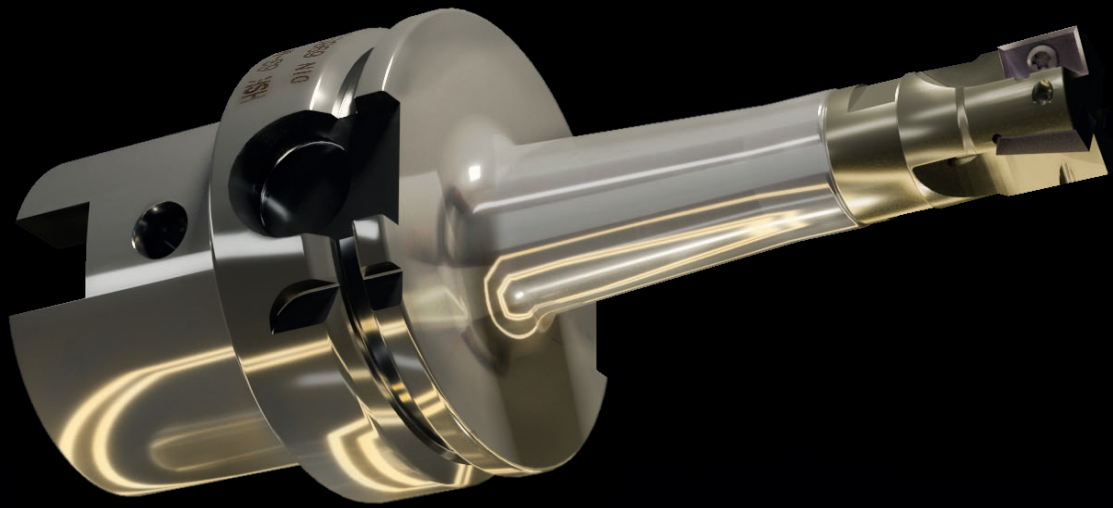



Vorgewuchtet  
Pre-balanced  
Pré-équilibré

G 6,3 15.000 min<sup>-1</sup>

G 2,5 Feinwuchten gegen Aufpreis  
G 2.5 Fine balancing at extra charge  
G 2,5 Equilibrage fin contre un supplément

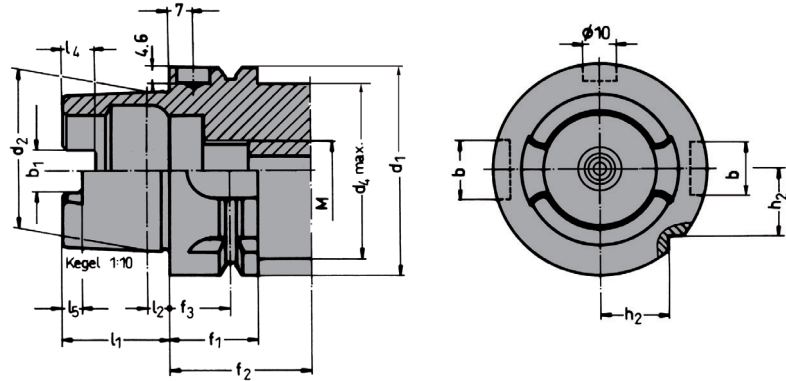

d <sub>1</sub>	d <sub>2</sub>	d <sub>4</sub>	l <sub>1</sub>	l <sub>2</sub>	l <sub>4</sub>	l <sub>5</sub>	M	f <sub>1</sub>	f <sub>2</sub>	f <sub>3</sub>	b <sub>1</sub>	b <sub>2</sub>	b <sub>3</sub>
32	24	26	16	3,2	5,0	3,0	M10 × 1	20	35	16	7,05	7	9
40	30	34	20	4,0	6,0	3,5	M12 × 1	20	35	16	8,05	9	11
50	38	42	25	5,0	7,5	4,5	M16 × 1	26	42	18	10,54	12	14
63	48	53	32	6,3	10,0	6,0	M18 × 1	26	42	18	12,54	16	18
80	60	67	40	8,0	12,0	8,0	M20 × 1,5	26	42	18	16,04	18	20
100	75	85	50	10,0	15,0	10,0	M24 × 1,5	29	45	20	20,02	22	20

**Werkstoff:** Legierter Einsatzstahl mit einer Zugfestigkeit im Kern von min. 800 N / mm<sup>2</sup>. Einsatzgehärtet HRC 60 ± 2 (HV 700 ± 50), Härtetiefe 0,8 mm ± 0,2 mm, brüniert und präzisionsgeschliffen.

**Material:** Alloyed case-hardened steel, tensile core strength of min. 800 N / mm<sup>2</sup>. Case hardened HRC 60 ± 2 (HV 700 ± 50), hardening depth 0.8 mm ± 0.2 mm, black-finished and precisely grinded.

**Matière:** Acier de cémentation allié. Résistance à la traction dans le noyau de min 800 N / mm<sup>2</sup>. Cémentation à HRC 60 ± 2 (HV 700 ± 50), profondeur de cémentation 0,8 mm ± 0,2 mm, bruni et rectifié précisément.



Index  
Sommaire

5.05	5.06	5.07	5.09
5.10	5.11	5.17	5.18
5.19	5.21	5.22	5.23
5.24	5.25	5.26	5.27
5.28	5.29	5.33	5.42
5.43	5.44	5.45	5.46
5.47	5.63	5.77	
HSK-C	HSK-E	HSK-F	





**Verwendung:**

Zur Aufnahme von Werkzeugen mit Zylinderschaft in Spannzangen.

**Application:**

For mounting straight-shank tools in collets.

**Application:**

Pour le serrage d'outils avec queue cylindrique dans des pinces de serrage.

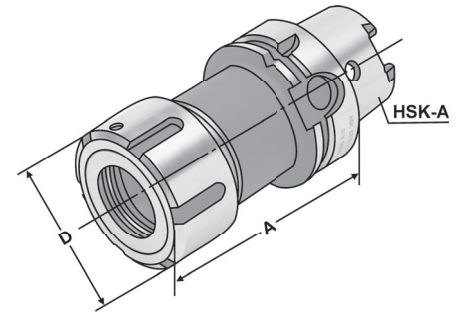

ISO 12164-1  
(DIN 69893-1)

HSK - A

$\nabla \leq 0,003$

G6,3  
15.000 min<sup>-1</sup>



5

Bestell-Nr. Order no. Référence	HSK	Spannbereich Capacity Capacité	A	D
A50.01.16	HSK-A 50	2 - 16 (OZ 16)	90	43
A50.01.25	HSK-A 50	2 - 25 (OZ 25)	110	60
A63.01.16	HSK-A 63	2 - 16 (OZ 16)	100	43
A63.01.25	HSK-A 63	2 - 25 (OZ 25)	100	60
A63.01.32	HSK-A 63	3 - 32 (OZ 32)	120	72
A100.01.16	HSK-A 100	2 - 16 (OZ 16)	110	43
A100.01.25	HSK-A 100	2 - 25 (OZ 25)	120	60
A100.01.32	HSK-A 100	3 - 32 (OZ 32)	130	72

**Lieferumfang:** Mit kugellagerter Spannmutter  
**Delivery:** With ball bearing clamping nut  
**Livraison:** Avec écrou de serrage à roulement à billes





Collet chucks for collets KPS-system  
Mandrins à pinces pour pinces système KPS



**Verwendung:**  
Zur Aufnahme von Werkzeugen mit Zylinder-  
schaft in Spannzangen.  
Für Anwendungen im HSC-Bereich und für  
hochpräzise Bearbeitungsergebnisse.

**Application:**  
For mounting straight-shank tools in collets.  
To use for high speed cutting and high  
precision milling.

**Application:**  
Pour le serrage d'outils avec queue cylindrique  
dans des pinces de serrage.  
Pour l'usage dans le coupage à grande vitesse  
et dans l'usinage à grande précision.

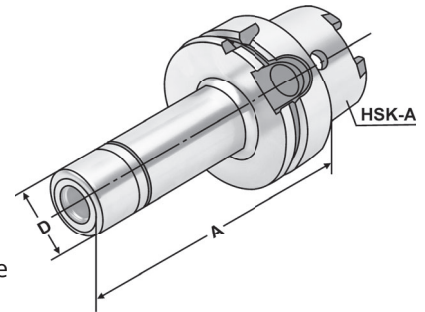

ISO 12164-1  
(DIN 69893-1)

HSK - A

$\nabla \leq 0,003$

G2,5  
30.000 min<sup>-1</sup>



Bestell-Nr. Order no. Référence	HSK	Spannbereich Capacity Capacité	A	D
A63.03.10	HSK-A 63	1 – 10 (KPS 10)	100	27,5
A63.03.10.2	HSK-A 63	1 – 10 (KPS 10)	160	27,5
A63.03.16	HSK-A 63	4 – 16 (KPS 16)	120	40,0
A63.03.16.2	HSK-A 63	4 – 16 (KPS 16)	160	40,0

5

**Lieferumfang:** Mit gewuchteter Spannmutter  
**Delivery:** With balanced clamping nut  
**Livraison:** Avec écrou de serrage équilibré

### Gewuchtete Ausführung

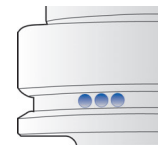

**Balanced type**  
**Type équilibré**

Bestell-Nr. Order no. Référence	Abmessung Size Dimension
---------------------------------------	--------------------------------

**Wuchten auf G 2,5 von vorgewuchteten  
Kemmler-Werkzeugen**

*Balancing at G 2.5 of pre-balanced Kemmler-tools*  
*Equilibrage sur G 2,5 d'outils Kemmler pré-équilibrés*

W25 **Ohne Wuchtprotokoll**  
*Without balancing report*  
*Sans protocole d'équilibrage*

W25.2 **Mit Wuchtprotokoll**  
*With balancing report*  
*Avec protocole d'équilibrage*

**Wuchten von nicht vorgewuchteten Werkzeugen**  
*Balancing of unbalanced tools*  
*Equilibrage d'outils non-équilibrés*

W25.1 **Ohne Wuchtprotokoll**  
*Without balancing report*  
*Sans protocole d'équilibrage*

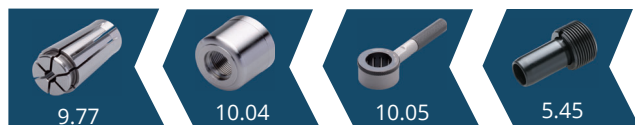



**Verwendung:**

Zur Aufnahme von Werkzeugen mit Zylinderschaft in Spannzangen.

**Application:**

For mounting straight-shank tools in collets.

**Application:**

Pour le serrage d'outils avec queue cylindrique dans des pinces de serrage.

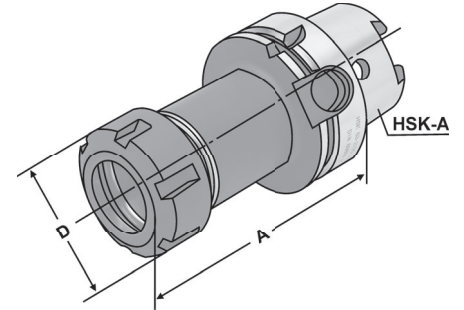

ISO 12164-1  
(DIN 69893-1)

HSK - A

$\nabla \leq 0,003$

G6,3  
15.000 min<sup>-1</sup>



5

Bestell-Nr. Order no. Référence	HSK	Spannbereich Capacity Capacité	A	D
A32.02.10	HSK-A 32	1 – 10 (ER 16)	80	32
A32.02.20	HSK-A 32	2 – 20 (ER 32)	85	50
A40.02.10	HSK-A 40	1 – 10 (ER 16)	80	32
A40.02.16	HSK-A 40	2 – 16 (ER 25)	80	42
A40.02.20	HSK-A 40	2 – 20 (ER 32)	80	50
A50.02.10	HSK-A 50	1 – 10 (ER 16)	100	32
A50.02.16	HSK-A 50	2 – 16 (ER 25)	80	42
A50.02.20	HSK-A 50	2 – 20 (ER 32)	100	50

**Lieferumfang:** Mit gewuchteter Spannmutter

**Delivery:** With balanced clamping nut

**Livraison:** Avec écrou de serrage équilibré





Collet chucks for collets DIN 6499 (ISO 15488) ER-system

DIN 69893 (HSK-A)

Mandrins à pinces pour pinces DIN 6499 (ISO 15488) système ER

**Verwendung:**

Zur Aufnahme von Werkzeugen mit Zylinderschaft in Spannzangen.

**Application:**

For mounting straight-shank tools in collets.

**Application:**

Pour le serrage d'outils avec queue cylindrique dans des pinces de serrage.

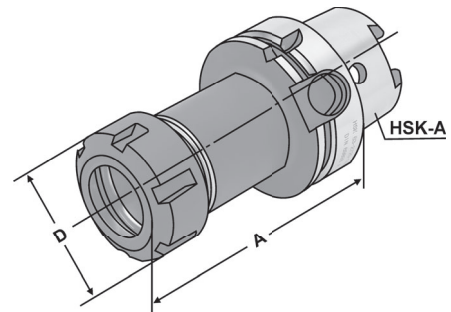
ISO 12164-1  
(DIN 69893-1)

HSK - A

 $\uparrow \leq 0,003$ G6,3  
15.000 min<sup>-1</sup>

14.04

Bestell-Nr. Order no. Référence	HSK	Spannbereich Capacity Capacité	A	D
A63.02.10.0	HSK-A 63	1 – 10 (ER 16)	75	32
A63.02.13.0	HSK-A 63	2 – 13 (ER 20)	75	35
A63.02.16.0	HSK-A 63	2 – 16 (ER 25)	75	42
A63.02.20.0	HSK-A 63	2 – 20 (ER 32)	75	50
A63.02.26.0	HSK-A 63	3 – 26 (ER 40)	85	63
A63.02.10	HSK-A 63	1 – 10 (ER 16)	100	32
A63.02.13	HSK-A 63	2 – 16 (ER 20)	100	35
A63.02.16	HSK-A 63	2 – 16 (ER 25)	100	42
A63.02.20	HSK-A 63	2 – 20 (ER 32)	100	50
A63.02.26	HSK-A 63	3 – 26 (ER 40)	120	63
A63.02.10.1	HSK-A 63	1 – 10 (ER 16)	160	32
A63.02.13.1	HSK-A 63	2 – 13 (ER 20)	160	35
A63.02.16.1	HSK-A 63	2 – 16 (ER 25)	160	42
A63.02.20.1	HSK-A 63	2 – 20 (ER 32)	160	50
A63.02.26.1	HSK-A 63	3 – 26 (ER 40)	160	63
A63.02.10.3	HSK-A 63	1 – 10 (ER 16)	200	32
A63.02.13.3	HSK-A 63	2 – 13 (ER 20)	200	35
A63.02.16.3	HSK-A 63	2 – 16 (ER 25)	200	42
A63.02.20.3	HSK-A 63	2 – 20 (ER 32)	200	50
A63.02.26.3	HSK-A 63	3 – 26 (ER 40)	200	63
A100.02.10	HSK-A 100	1 – 10 (ER 16)	100	32
A100.02.16	HSK-A 100	2 – 16 (ER 25)	100	42
A100.02.20	HSK-A 100	2 – 20 (ER 32)	100	50
A100.02.26	HSK-A 100	3 – 26 (ER 40)	120	63
A100.02.10.2	HSK-A 100	1 – 10 (ER 16)	160	32
A100.02.16.2	HSK-A 100	2 – 16 (ER 25)	160	42
A100.02.20.2	HSK-A 100	2 – 20 (ER 32)	160	50
A100.02.26.2	HSK-A 100	3 – 26 (ER 40)	160	63

**Lieferumfang:** Mit gewichteter Spannmutter**Delivery:** With balanced clamping nut**Livraison:** Avec écrou de serrage équilibré





# Spannfutter für Spannzangen DIN 6499 (ISO 15488) System ER - MiniISO 12164 (HSK-A)

Collet chucks for collets DIN 6499 (ISO 15488) ER-system - Mini  
Mandrins à pinces pour pinces DIN 6499 (ISO 15488) système ER - Mini

DIN 69893 (HSK-A)



**Verwendung:**  
Zur Aufnahme von Werkzeugen mit Zylinderschaft in Spannzangen.  
**Application:**  
For mounting straight-shank tools in collets.  
**Application:**  
Pour le serrage d'outils avec queue cylindrique dans des pinces de serrage.

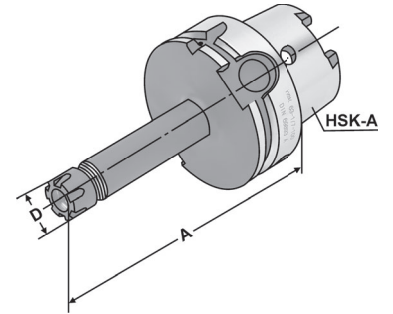

ISO 12164-1  
(DIN 69893-1)

HSK - A

$\nabla \leq 0,003$

G2.5  
30.000 min<sup>-1</sup>



5

Bestell-Nr. Order no. Référence	HSK	Spannbereich Capacity Capacité	A	D
A32.02.07.M	HSK-A 32	1 – 7 (ER 11) Mini	50	16
A32.02.10.M	HSK-A 32	1 – 10 (ER 16) Mini	50	22
A32.02.16.M	HSK-A 32	2 – 16 (ER 25) Mini	80	35
A40.02.07.M	HSK-A 40	1 – 7 (ER 11) Mini	40	16
A40.02.10.M	HSK-A 40	1 – 10 (ER 16) Mini	80	22
A50.02.07.M	HSK-A 50	1 – 7 (ER 11) Mini	60	16
A50.02.10.M	HSK-A 50	1 – 10 (ER 16) Mini	60	22
A63.02.07.1	HSK-A 63	1 – 7 (ER 11)	100	16
A63.02.07.2	HSK-A 63	1 – 7 (ER 11)	160	16
A63.02.07.10.1	HSK-A 63	1 – 10 (ER 16)	100	22
A63.02.07.10.2	HSK-A 63	1 – 10 (ER 16)	160	22

## Gewuchtete Ausführung

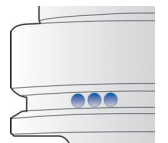

Balanced type  
Type équilibré

Bestell-Nr. Order no. Référence	Abmessung Size Dimension
---------------------------------------	--------------------------------

Wuchten auf G 2,5 von vorgewuchteten  
Kemmler-Werkzeugen

Balancing at G 2.5 of pre-balanced Kemmler-tools  
Équilibrage sur G 2,5 d'outils Kemmler pré-équilibrés  
W25

Ohne Wuchtprotokoll  
Without balancing report  
Sans protocole d'équilibrage

W25.2

Mit Wuchtprotokoll  
With balancing report  
Avec protocole d'équilibrage

Wuchten von nicht vorgewuchteten Werkzeugen  
Balancing of unbalanced tools  
Équilibrage d'outils non-équilibrés

W25.1

Ohne Wuchtprotokoll  
Without balancing report  
Sans protocole d'équilibrage





**Verwendung:**  
Zur Aufnahme von Werkzeugen mit Zylinderschaft nach DIN 1835 Form A+B+E und DIN 6535 Form HA+HB+HE.

**Application:**  
For mounting straight-shank tools acc. DIN 1835 form A+B+E and DIN 6535 form HA+HB+HE.

**Application:**  
Pour le serrage d'outils avec queue cylindrique suivant DIN 1835 forme A+B+E et DIN 6535 forme HA+HB+HE.

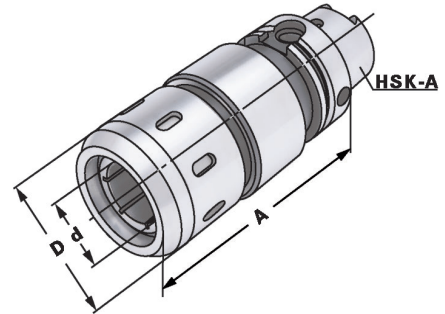

ISO 12164-1  
(DIN 69893-1)

HSK - A

$\nabla \leq 0,003$

G6.3  
15.000 min<sup>-1</sup>



Bestell-Nr. Order no. Référence	HSK	Spannbereich Capacity Capacité	A	D	d
A63.64.20	HSK-A 63	20 (HKS 20)	95	53	20
A63.64.25	HSK-A 63	25 (HKS 25)	100	63	25
A63.64.32	HSK-A 63	32 (HKS 32)	110	68	32
A100.64.20	HSK-A 100	20 (HKS 20)	105	53	20
A100.64.25	HSK-A 100	25 (HKS 25)	105	63	25
A100.64.32	HSK-A 100	32 (HKS 32)	105	68	32



**Verwendung:**

Zum Spannen von zylindrischen Werkzeugschäften mit seitlicher Spannfläche nach DIN 1835 Form B (Weldon).

**Application:**

For mounting straight-shank tools with lateral flat according to DIN 1835 form B (Weldon).

**Application:**

Pour le serrage d'outils avec queue cylindrique et avec méplat suivant DIN 1835 forme B (Weldon).

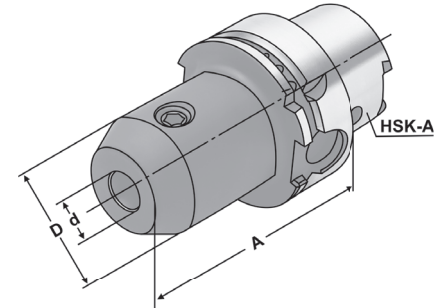
ISO 12164-1  
(DIN 69893-1)

HSK - A

 $\nabla \leq 0,003$ G6,3  
15.000 min<sup>-1</sup>

5

Bestell-Nr. Order no. Référence	HSK	d <sup>H4</sup>	A	D
A32.04.06	HSK-A 32	6	60	25
A32.04.08	HSK-A 32	8	60	28
A32.04.10	HSK-A 32	10	65	35
A32.04.12	HSK-A 32	12	70	42
A32.04.14	HSK-A 32	14	75	44
A32.04.16	HSK-A 32	16	75	48
A32.04.20	HSK-A 32	20	90	50
A40.04.06	HSK-A 40	6	60	25
A40.04.08	HSK-A 40	8	60	28
A40.04.10	HSK-A 40	10	60	35
A40.04.12	HSK-A 40	12	70	42
A40.04.14	HSK-A 40	14	75	44
A40.04.16	HSK-A 40	16	75	40
A40.04.18	HSK-A 40	18	85	40
A40.04.20	HSK-A 40	20	85	40
A40.04.25	HSK-A 40	25	100	45
A40.04.32	HSK-A 40	32	105	60
A50.04.06	HSK-A 50	6	65	25
A50.04.08	HSK-A 50	8	65	28
A50.04.10	HSK-A 50	10	65	35
A50.04.12	HSK-A 50	12	80	42
A50.04.14	HSK-A 50	14	80	44
A50.04.16	HSK-A 50	16	80	48
A50.04.18	HSK-A 50	18	80	50
A50.04.20	HSK-A 50	20	80	52
A50.04.25	HSK-A 50	25	110	60
A50.04.32	HSK-A 50	32	110	60

**Hinweis:** Ab d = 25 mit zwei Spannschrauben  
**Note:** From d = 25 on two clamping screws  
**Observation:** A partir de d = 25 avec deux vis de serrage

**Lieferumfang:** Mit Spannschraube  
**Delivery:** With clamping screw  
**Livraison:** Avec vis de serrage



End mill holders DIN 6359 for end mills DIN 1835-B

Porte-fraises DIN 6359 pour queues cylindriques DIN 1835-B

DIN 69893 (HSK-A)

**Verwendung:**

Zum Spannen von zylindrischen Werkzeugschäften mit seitlicher Spannfläche nach DIN 1835 Form B (Weldon).

**Application:**

For mounting straight-shank tools with lateral flat according to DIN 1835 form B (Weldon).

**Application:**

Pour le serrage d'outils avec queue cylindrique et avec méplat suivant DIN 1835 forme B (Weldon).

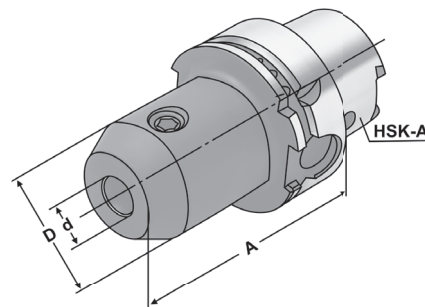
ISO 12164-1  
(DIN 69893-1)

HSK - A

 $\lambda \leq 0,003$ G6,3  
15.000 min<sup>-1</sup>

14.04

Bestell-Nr. Order no. Référence	HSK	d <sup>H4</sup>	A	D
A63.04.06	HSK-A 63	6	65	25
A63.04.08	HSK-A 63	8	65	28
A63.04.10	HSK-A 63	10	65	35
A63.04.12	HSK-A 63	12	80	42
A63.04.14	HSK-A 63	14	80	44
A63.04.16	HSK-A 63	16	80	48
A63.04.18	HSK-A 63	18	80	50
A63.04.20	HSK-A 63	20	80	52
A63.04.25	HSK-A 63	25	110	65
A63.04.32	HSK-A 63	32	110	72
A63.04.40	HSK-A 63	40	125	80
A63.04.06.1	HSK-A 63	6	100	25
A63.04.08.1	HSK-A 63	8	100	28
A63.04.10.1	HSK-A 63	10	100	35
A63.04.12.1	HSK-A 63	12	100	35
A63.04.14.1	HSK-A 63	14	100	44
A63.04.16.1	HSK-A 63	16	100	48
A63.04.18.1	HSK-A 63	18	100	50
A63.04.20.1	HSK-A 63	20	100	52
A63.04.06.2	HSK-A 63	6	160	25
A63.04.08.2	HSK-A 63	8	160	28
A63.04.10.2	HSK-A 63	10	160	35
A63.04.12.2	HSK-A 63	12	160	35
A63.04.14.2	HSK-A 63	14	160	44
A63.04.16.2	HSK-A 63	16	160	48
A63.04.18.2	HSK-A 63	18	160	50
A63.04.20.2	HSK-A 63	20	160	52

**Hinweis:**

Ab d = 25 mit zwei Spannschrauben

**Note:**

From d = 25 on two clamping screws

**Observation:**

A partir de d = 25 avec deux vis de serrage

**Lieferumfang:**

Mit Spannschraube

**Delivery:**

With clamping screw

**Livraison:**

Avec vis de serrage



**Verwendung:**

Zum Spannen von zylindrischen Werkzeugschäften mit seitlicher Spannfläche nach DIN 1835 Form B (Weldon).

**Application:**

For mounting straight-shank tools with lateral flat according to DIN 1835 form B (Weldon).

**Application:**

Pour le serrage d'outils avec queue cylindrique et avec méplat suivant DIN 1835 forme B (Weldon).

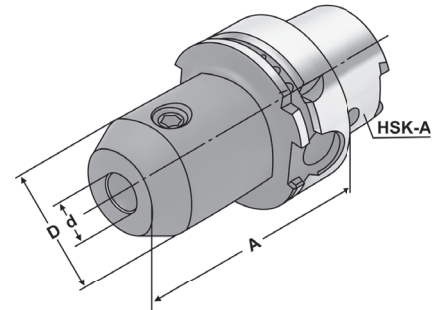
ISO 12164-1  
(DIN 69893-1)

HSK - A

 $\nabla \leq 0,003$ G6,3  
15.000 min<sup>-1</sup>

5

Bestell-Nr. Order no. Référence	HSK	d <sup>H4</sup>	A	D
A80.04.06	HSK-A 80	6	80	25
A80.04.08	HSK-A 80	8	80	28
A80.04.10	HSK-A 80	10	80	35
A80.04.12	HSK-A 80	12	80	42
A80.04.14	HSK-A 80	14	80	44
A80.04.16	HSK-A 80	16	100	48
A80.04.18	HSK-A 80	18	100	50
A80.04.20	HSK-A 80	20	100	52
A80.04.25	HSK-A 80	25	100	65
A80.04.32	HSK-A 80	32	110	72
A80.04.40	HSK-A 80	40	120	80
A100.04.06	HSK-A 100	6	80	25
A100.04.08	HSK-A 100	8	80	28
A100.04.10	HSK-A 100	10	80	35
A100.04.12	HSK-A 100	12	80	42
A100.04.14	HSK-A 100	14	80	44
A100.04.16	HSK-A 100	16	100	48
A100.04.18	HSK-A 100	18	100	50
A100.04.20	HSK-A 100	20	100	52
A100.04.25	HSK-A 100	25	100	65
A100.04.32	HSK-A 100	32	100	72
A100.04.40	HSK-A 100	40	105	80
A100.04.06.2	HSK-A 100	6	160	25
A100.04.08.2	HSK-A 100	8	160	28
A100.04.10.2	HSK-A 100	10	160	35
A100.04.12.2	HSK-A 100	12	160	35
A100.04.14.2	HSK-A 100	14	160	44
A100.04.16.2	HSK-A 100	16	160	48
A100.04.18.2	HSK-A 100	18	160	50
A100.04.20.2	HSK-A 100	20	160	52
A100.04.25.2	HSK-A 100	25	160	65
A100.04.32.2	HSK-A 100	32	160	72
A100.04.40.2	HSK-A 100	40	160	80

**Hinweis:****Note:****Observation:**

Ab d = 25 mit zwei Spannschrauben

From d = 25 on two clamping screws

A partir de d = 25 avec deux vis de serrage

**Lieferumfang:****Delivery:****Livraison:**

Mit Spannschraube

With clamping screw

Avec vis de serrage

## End mill holders DIN 6359 with coolant channels for end mills DIN 1835-B

## Porte-fraises DIN 6359 avec canaux d'arrosage pour queues cylindriques DIN 1835-B

**Verwendung:**

Zum Spannen von zylindrischen Werkzeugschäften mit seitlicher Spannfläche nach DIN 1835 Form B (Weldon). Mit Kühlkanälen für optimale Kühlung der Werkzeugschneide.

**Application:**

For mounting straight-shank tools with lateral flat according to DIN 1835 form B (Weldon). With coolant channels for optimal coolant at the cutting edge.

**Application:**

Pour le serrage d'outils avec queue cylindrique et avec méplat suivant DIN 1835 forme B (Weldon). Avec canaux d'arrosage pour un refroidissement optimal aux lames.

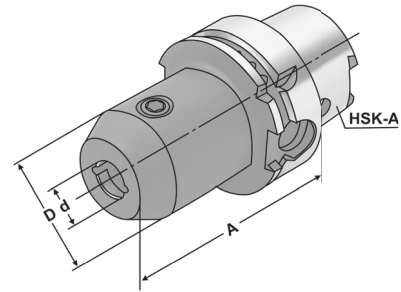
ISO 12164-1  
(DIN 69893-1)

HSK - A

 $\lambda \leq 0,003$ G6.3  
15.000 min<sup>-1</sup>

14.04

Bestell-Nr. Order no. Référence	HSK	d <sup>H4</sup>	A	D
A63.04.06.K	HSK-A 63	6	65	25
A63.04.08.K	HSK-A 63	8	65	28
A63.04.10.K	HSK-A 63	10	65	35
A63.04.12.K	HSK-A 63	12	80	42
A63.04.14.K	HSK-A 63	14	80	44
A63.04.16.K	HSK-A 63	16	80	48
A63.04.18.K	HSK-A 63	18	80	50
A63.04.20.K	HSK-A 63	20	80	52
A63.04.25.K	HSK-A 63	25	110	65
A63.04.32.K	HSK-A 63	32	110	72
A63.04.40.K	HSK-A 63	40	125	80
A63.04.06.1.K	HSK-A 63	6	100	25
A63.04.08.1.K	HSK-A 63	8	100	28
A63.04.10.1.K	HSK-A 63	10	100	35
A63.04.12.1.K	HSK-A 63	12	100	42
A63.04.14.1.K	HSK-A 63	14	100	44
A63.04.16.1.K	HSK-A 63	16	100	48
A63.04.18.1.K	HSK-A 63	18	100	50
A63.04.20.1.K	HSK-A 63	20	100	52
A100.04.06.K	HSK-A 100	6	80	25
A100.04.08.K	HSK-A 100	8	80	28
A100.04.10.K	HSK-A 100	10	80	35
A100.04.12.K	HSK-A 100	12	80	42
A100.04.14.K	HSK-A 100	14	80	44
A100.04.16.K	HSK-A 100	16	100	48
A100.04.18.K	HSK-A 100	18	100	50
A100.04.20.K	HSK-A 100	20	100	52
A100.04.25.K	HSK-A 100	25	100	65
A100.04.32.K	HSK-A 100	32	100	72
A100.04.40.K	HSK-A 100	40	105	80

**Hinweis:**

d = 6 bis 18 mit zwei Kühlkanälen

d = 20 bis 40 mit vier Kühlkanälen

Für Werkzeuge mit innerer Kühlmittelzufuhr muss ein O-Ring eingesetzt werden.

**Note:**

d = 6 to 18 with two coolant channels

d = 20 to 40 with four coolant channels

For tools with through coolant an O-ring must be used.

**Observation:**

d = 6 bis 18 avec deux canaux d'arrosage

d = 20 bis 40 avec quatre canaux d'arrosage

Pour outils avec arrosage interne il faut utiliser un joint torique.



**Verwendung:**

Zum Spannen von zylindrischen Werkzeugschäften mit geneigter Spannfläche nach DIN 1835 Form E (Whistle Notch).

**Application:**

For mounting straight-shank tools and inclined flat according to DIN 1835 form E (Whistle Notch).

**Application:**

Pour le serrage d'outils avec queue cylindrique et avec méplat incliné suivant DIN 1835 forme E (Whistle Notch).

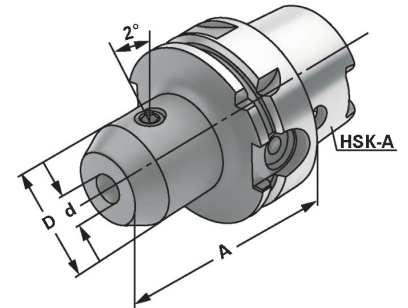
ISO 12164-1  
(DIN 69893-1)

HSK - A

 $\nabla \leq 0,003$ G6,3  
15.000 min<sup>-1</sup>

5

Bestell-Nr. Order no. Référence	HSK	d <sup>H4</sup>	A	D
A32.05.06	HSK-A 32	6	80	25
A32.05.08	HSK-A 32	8	80	28
A32.05.10	HSK-A 32	10	80	32
A32.05.12	HSK-A 32	12	80	32
A32.05.14	HSK-A 32	14	80	32
A32.05.16	HSK-A 32	16	90	32
A32.05.18	HSK-A 32	18	90	34
A32.05.20	HSK-A 32	20	90	34
A40.05.06	HSK-A 40	6	80	25
A40.05.08	HSK-A 40	8	80	28
A40.05.10	HSK-A 40	10	80	35
A40.05.12	HSK-A 40	12	90	42
A40.05.14	HSK-A 40	14	90	44
A40.05.16	HSK-A 40	16	90	48
A40.05.18	HSK-A 40	18	90	40
A40.05.20	HSK-A 40	20	90	40
A40.05.25	HSK-A 40	25	100	46
A40.05.32	HSK-A 40	32	110	54
A50.05.06	HSK-A 50	6	80	25
A50.05.08	HSK-A 50	8	80	28
A50.05.10	HSK-A 50	10	80	35
A50.05.12	HSK-A 50	12	90	42
A50.05.14	HSK-A 50	14	90	44
A50.05.16	HSK-A 50	16	90	48
A50.05.18	HSK-A 50	18	90	50
A50.05.20	HSK-A 50	20	100	52
A50.05.25	HSK-A 50	25	110	60
A50.05.32	HSK-A 50	32	110	60

**Hinweis:** Ab d = 25 mit zwei Spannschrauben  
**Note:** From d = 25 on two clamping screws  
**Observation:** A partir de d = 25 avec deux vis de serrage

**Lieferumfang:** Mit Spannschraube und axialer Verstellechraube  
**Delivery:** With clamping screw and axial adjustment bolt  
**Livraison:** Avec vis de serrage et vis de butée axiale



End mill holders DIN 6359 for end mills DIN 1835-E

Porte-fraises DIN 6359 pour queues cylindriques DIN 1835-E

DIN 69893 (HSK-A)

**Verwendung:**

Zum Spannen von zylindrischen Werkzeugschäften mit geneigter Spannfläche nach DIN 1835 Form E (Whistle Notch).

**Application:**

For mounting straight-shank tools and inclined flat according to DIN 1835 form E (Whistle Notch).

**Application:**

Pour le serrage d'outils avec queue cylindrique et avec méplat incliné suivant DIN 1835 forme E (Whistle Notch).

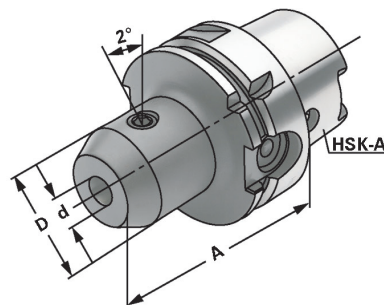
ISO 12164-1  
(DIN 69893-1)

HSK - A

 $\nabla \leq 0,003$ G6.3  
15.000 min<sup>-1</sup>

14.04

Bestell-Nr. Order no. Référence	HSK	d <sup>H4</sup>	A	D
A63.05.06	HSK-A 63	6	80	25
A63.05.08	HSK-A 63	8	80	28
A63.05.10	HSK-A 63	10	80	35
A63.05.12	HSK-A 63	12	90	42
A63.05.14	HSK-A 63	14	90	44
A63.05.16	HSK-A 63	16	100	48
A63.05.18	HSK-A 63	18	100	50
A63.05.20	HSK-A 63	20	100	52
A63.05.25	HSK-A 63	25	110	65
A63.05.32	HSK-A 63	32	110	72
A80.05.06	HSK-A 80	6	90	25
A80.05.08	HSK-A 80	8	90	28
A80.05.10	HSK-A 80	10	90	35
A80.05.12	HSK-A 80	12	100	42
A80.05.14	HSK-A 80	14	100	44
A80.05.16	HSK-A 80	16	100	48
A80.05.18	HSK-A 80	18	100	50
A80.05.20	HSK-A 80	20	110	52
A80.05.25	HSK-A 80	25	110	65
A80.05.32	HSK-A 80	32	120	72
A100.05.06	HSK-A 100	6	90	25
A100.05.08	HSK-A 100	8	90	28
A100.05.10	HSK-A 100	10	90	35
A100.05.12	HSK-A 100	12	100	42
A100.05.14	HSK-A 100	14	100	44
A100.05.16	HSK-A 100	16	100	48
A100.05.18	HSK-A 100	18	100	50
A100.05.20	HSK-A 100	20	110	52
A100.05.25	HSK-A 100	25	120	65
A100.05.32	HSK-A 100	32	120	72
A100.05.40	HSK-A 100	40	120	80

**Hinweis:** Ab d = 25 mit zwei Spannschrauben**Note:** From d = 25 on two clamping screws**Observation:** A partir de d = 25 avec deux vis**Lieferumfang:** Mit Spannschraube und axialer Verstellechraube**Delivery:** With clamping screw and axial adjustment bolt**Livraison:** Avec vis de serrage et vis de butée axiale



**Verwendung:**

Zur Aufnahme von Einschraubfräser mit Gewinde.

**Application:**

For mounting screw-in cutters with thread.

**Application:**

Pour le serrage de fraises à queue fileté.

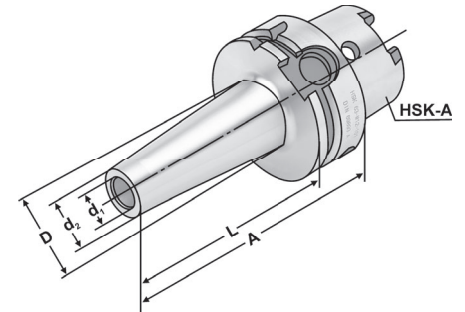
ISO 12164-1  
(DIN 69893-1)

HSK - A

 $\lambda \leq 0,003$ G6,3  
15.000 min<sup>-1</sup>

5

Bestell-Nr. Order no. Référence	HSK	M	d <sub>1</sub> <sup>H4</sup>	d <sub>2</sub>	D	A	L
A63.06.06	HSK-A 63	6	6,5	10	13	51	25
A63.06.08	HSK-A 63	8	8,5	13	15	51	25
A63.06.08.1	HSK-A 63	8	8,5	13	23	76	50
A63.06.08.2	HSK-A 63	8	8,5	13	23	101	75
A63.06.10	HSK-A 63	10	10,5	18	20	51	25
A63.06.10.1	HSK-A 63	10	10,5	18	23	76	50
A63.06.10.3	HSK-A 63	10	10,5	18	32	126	100
A63.06.10.5	HSK-A 63	10	10,5	18	37	176	150
A63.06.12	HSK-A 63	12	12,5	21	24	51	25
A63.06.12.1	HSK-A 63	12	12,5	21	24	76	50
A63.06.12.2	HSK-A 63	12	12,5	21	31	101	75
A63.06.12.3	HSK-A 63	12	12,5	21	33	126	100
A63.06.12.5	HSK-A 63	12	12,5	21	40	176	150
A63.06.16	HSK-A 63	16	17	29	29	51	25
A63.06.16.1	HSK-A 63	16	17	29	34	76	50
A63.06.16.2	HSK-A 63	16	17	29	34	101	75
A63.06.16.3	HSK-A 63	16	17	29	36	126	100
A63.06.16.5	HSK-A 63	16	17	29	43	176	150
A100.06.08.1	HSK-A 100	8	8,5	13	23	79	50
A100.06.10.1	HSK-A 100	10	10,5	18	23	79	50
A100.06.10.3	HSK-A 100	10	10,5	18	32	129	100
A100.06.10.5	HSK-A 100	10	10,5	18	37	179	150
A100.06.12.1	HSK-A 100	12	12,5	21	24	79	50
A100.06.12.3	HSK-A 100	12	12,5	21	33	129	100
A100.06.12.5	HSK-A 100	12	12,5	21	40	179	150
A100.06.16.1	HSK-A 100	16	17	29	34	79	50
A100.06.16.3	HSK-A 100	16	17	29	36	129	100
A100.06.16.5	HSK-A 100	16	17	29	43	179	150

**Empfohlenes Anzugsmoment**  
**Recommended tightening torques**  
**Torques de serrage recommandés**

M6	10 Nm
M8	25 Nm
M10	40 Nm
M12	60 Nm
M16	50 Nm





Combi shell mill holders DIN 6358  
 Porte-fraises à double usage DIN 6358

DIN 69893 (HSK-A)



**Verwendung:**  
 Zur Aufnahme von Walzen-, Walzenstirnfräsern oder Messerköpfen mit Längs- oder Quernut.

**Application:**  
 For mounting milling cutters with transverse or longitudinal groove.

**Application:**  
 Pour le serrage de fraises à rainure transversale ou à rainure longitudinale.

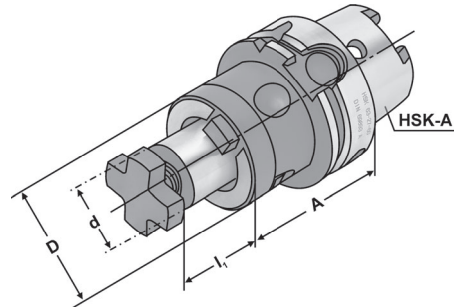

ISO 12164-1 (DIN 69893-1)    HSK - A     $\nabla \leq 0,005$     G6,3 15.000 min<sup>-1</sup>

Bestell-Nr. Order no. Référence	HSK	d <sub>h6</sub>	A	l <sub>1</sub>	D
A32.10.16	HSK-A 32	16	55	17	32
A32.10.22	HSK-A 32	22	55	19	40
A32.10.27	HSK-A 32	27	65	21	48
A32.10.32	HSK-A 32	32	65	24	58
A32.10.40	HSK-A 32	40	65	27	70
A40.10.16	HSK-A 40	16	50	17	32
A40.10.22	HSK-A 40	22	50	19	40
A40.10.27	HSK-A 40	27	65	21	48
A40.10.32	HSK-A 40	32	65	24	58
A50.10.16	HSK-A 50	16	50	17	32
A50.10.22	HSK-A 50	22	50	19	40
A50.10.27	HSK-A 50	27	65	21	48
A50.10.32	HSK-A 50	32	65	24	58
A63.10.16	HSK-A 63	16	60	17	32
A63.10.22	HSK-A 63	22	60	19	40
A63.10.27	HSK-A 63	27	60	21	48
A63.10.32	HSK-A 63	32	60	24	58
A63.10.40	HSK-A 63	40	70	27	70
A63.10.16.1	HSK-A 63	16	100	17	32
A63.10.22.1	HSK-A 63	22	100	19	40
A63.10.27.1	HSK-A 63	27	100	21	48
A63.10.32.1	HSK-A 63	32	100	24	58
A80.10.16	HSK-A 80	16	60	17	32
A80.10.22	HSK-A 80	22	60	19	40
A80.10.27	HSK-A 80	27	60	21	48
A80.10.32	HSK-A 80	32	60	24	58
A80.10.40	HSK-A 80	40	70	27	70
A100.10.16	HSK-A 100	16	60	17	32
A100.10.22	HSK-A 100	22	60	19	40
A100.10.27	HSK-A 100	27	60	21	48
A100.10.32	HSK-A 100	32	60	24	58
A100.10.40	HSK-A 100	40	70	27	70

**Lieferumfang:** Mit Fräseranzugsschraube, Mitnehmerring und Passfeder  
**Delivery:** With tightening bolt, driving ring and feather key  
**Livraison:** Avec vis de blocage, bague d'entraînement et clavette





Shell mill holders DIN 6357 with enlarged contact face and coolant exit bores on the end face

Porte-fraises à trou lisse DIN 6357 avec face de contact élargie et conduits pour l'arrosage frontal



**Verwendung:**

Zur Aufnahme von Messerköpfen und Fräsern mit Quernut.

**Application:**

For mounting milling cutters with transversal groove.

**Application:**

Pour le serrage de fraises à rainure transversale.

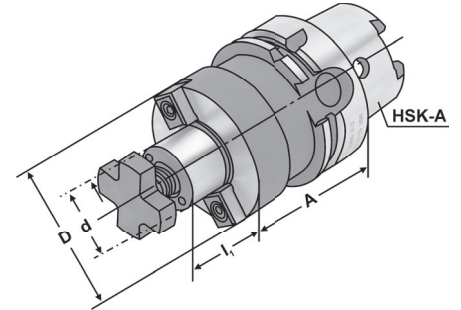

ISO 12164-1  
(DIN 69893-1)

HSK - A

$\nabla \leq 0,005$

G6,3  
15.000 min<sup>-1</sup>

5

Bestell-Nr. Order no. Référence	HSK	d <sub>H6</sub>	A	l <sub>1</sub>	D
A40.11.22	HSK-A 40	22	50	19	48
A40.11.27	HSK-A 40	27	55	21	60
A40.11.32	HSK-A 40	32	60	24	78
A50.11.16	HSK-A 50	16	50	17	40
A50.11.22	HSK-A 50	22	60	19	48
A50.11.27	HSK-A 50	27	60	21	60
A50.11.32	HSK-A 50	32	60	24	78
A63.11.16	HSK-A 63	16	50	17	38
A63.11.22	HSK-A 63	22	50	19	48
A63.11.27	HSK-A 63	27	60	21	58
A63.11.32	HSK-A 63	32	60	24	78
A63.11.40	HSK-A 63	40	60	27	88
A63.11.16.1	HSK-A 63	16	100	17	38
A63.11.22.1	HSK-A 63	22	100	19	48
A63.11.27.1	HSK-A 63	27	100	21	58
A63.11.32.1	HSK-A 63	32	100	24	78
A63.11.40.1	HSK-A 63	40	100	27	88
A63.11.16.2	HSK-A 63	16	160	17	38
A63.11.22.2	HSK-A 63	22	160	19	48
A63.11.27.2	HSK-A 63	27	160	21	58
A63.11.32.2	HSK-A 63	32	160	24	78
A63.11.40.2	HSK-A 63	40	160	27	88

d = 40:

Für große Planfräser mit vier zusätzlichen Gewindebohrungen nach DIN 2079.

For large diameter face mill cutters with four additional threaded holes according to DIN 2079.

Pour fraises à surfacer à grands diamètres avec quatre trous taraudés additionnels suivant DIN 2079.

**Lieferumfang:** Mit Mitnehmersteinen, Kreuzschraube und Zylinderkopfschraube nach DIN 912 für Fräser mit innerer Kühlmittelzufuhr.

**Delivery:** With drivers, cross head retaining screw and cylinder head retaining screw for cutters with central coolant.

**Livraison:** Avec tenons, une vis cruciforme et une vis à tête cylindrique suivant DIN 912 pour fraises avec arrosage central.



10.50



10.48



10.49

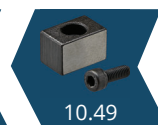

10.49



5.45





Shell mill holders DIN 6357 with enlarged contact face and coolant exit bores on the end face  
 Porte-fraises à trou lisse DIN 6357 avec face de contact élargie et conduits pour l'arrosage frontal



**Verwendung:**  
 Zur Aufnahme von Messerköpfen und Fräsern mit Quernut.  
**Application:**  
 For mounting milling cutters with transversal groove.  
**Application:**  
 Pour le serrage de fraises à rainure transversale.

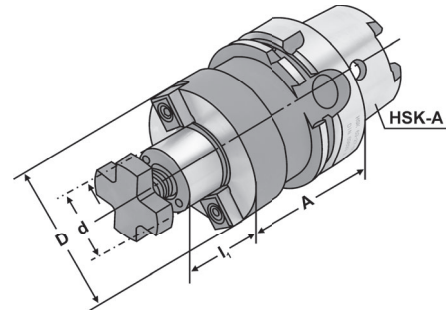

ISO 12164-1 (DIN 69893-1)    HSK - A     $\lambda \leq 0,005$     G6,3 15.000 min<sup>-1</sup>

Bestell-Nr. Order no. Référence	HSK	d <sub>H6</sub>	A	l <sub>1</sub>	D
A80.11.22	HSK-A 80	22	50	19	48
A80.11.27	HSK-A 80	27	50	21	58
A80.11.32	HSK-A 80	32	60	24	78
A80.11.40	HSK-A 80	40	60	27	88
A100.11.16	HSK-A 100	16	50	17	38
A100.11.22	HSK-A 100	22	50	19	48
A100.11.27	HSK-A 100	27	50	21	58
A100.11.32	HSK-A 100	32	50	24	78
A100.11.40	HSK-A 100	40	70	27	88
A100.11.60	HSK-A 100	60	70	40	130
A100.11.16.1	HSK-A 100	16	100	17	38
A100.11.22.1	HSK-A 100	22	100	19	48
A100.11.27.1	HSK-A 100	27	100	21	58
A100.11.32.1	HSK-A 100	32	100	24	78
A100.11.40.1	HSK-A 100	40	100	27	88



**d = 40/d = 60:** Für große Planfräser mit vier zusätzlichen Gewindebohrungen nach DIN 2079.  
 For large diameter face mill cutters with four additional threaded holes according to DIN 2079.  
 Pour fraises à surfacer à grands diamètres avec quatre trous taraudés additionnels suivant DIN 2079.

**Lieferumfang:** Mit Mitnehmersteinen, Kreuzschraube und Zylinderkopfschraube nach DIN 912 für Fräser mit innerer Kühlmittelzufuhr.  
 Bei d = 60 nur mit vier Befestigungsschrauben nach DIN 912.

**Delivery:** With drivers, cross head retaining screw and cylinder head retaining screw for cutters with central coolant.  
 For d = 60 only with four fixation screws according to DIN 912.

**Livraison:** Avec tenons, une vis cruciforme et une vis à tête cylindrique suivant DIN 912 pour fraises avec arrosage central.  
 Pour d = 60 seulement avec quatre vis de fixation suivant DIN 912.





**Verwendung:**  
Zur Aufnahme von Werkzeugen mit Morsekegelschaft und Austreiblappen nach DIN 228-1 Form B.

**Application:**  
For mounting tools with Morse taper shank and tang according to DIN 228-1 form B.

**Application:**  
Pour le serrage d'outils avec queue cône Morse et tenon suivant DIN 228-1 forme B.

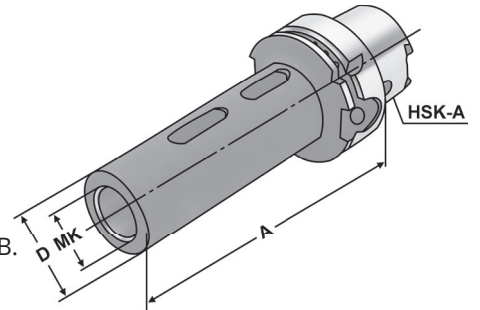

ISO 12164-1  
(DIN 69893-1)

HSK - A

$\nabla \leq 0,005$

G6,3  
15.000 min<sup>-1</sup>

5

Bestell-Nr. Order no. Référence	HSK	MK MT CM	A	D
A50.07.01	HSK-A 50	1	100	25
A50.07.02	HSK-A 50	2	120	32
A50.07.03	HSK-A 50	3	140	40
A63.07.01	HSK-A 63	1	100	25
A63.07.02	HSK-A 63	2	120	32
A63.07.03	HSK-A 63	3	140	40
A63.07.04	HSK-A 63	4	160	48
A80.07.01	HSK-A 80	1	110	25
A80.07.02	HSK-A 80	2	120	32
A80.07.03	HSK-A 80	3	140	40
A80.07.04	HSK-A 80	4	160	48
A100.07.01	HSK-A 100	1	110	25
A100.07.02	HSK-A 100	2	120	32
A100.07.03	HSK-A 100	3	150	40
A100.07.04	HSK-A 100	4	170	48
A100.07.05	HSK-A 100	5	200	63





Adaptor sleeves for MT with drawbar thread DIN 6364  
 Douilles de réduction pour CM avec filetage DIN 6364

DIN 69893 (HSK-A)



**Verwendung:**  
 Zum Spannen von Werkzeugen mit Morsekegelschaft und Anzugsgewinde nach DIN 228-1 Form A.

**Application:**  
 For clamping tools with Morse taper shank and thread according to DIN 228-1 form A.

**Application:**  
 Pour le serrage d'outils avec queue cône Morse et filetage suivant DIN 228-1 forme A.

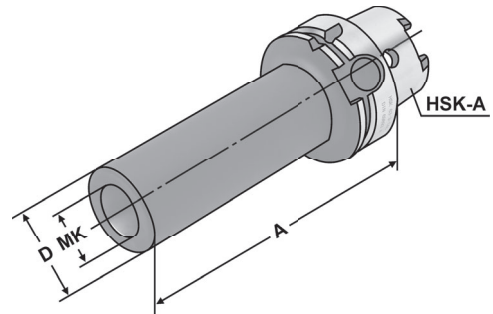

ISO 12164-1  
 (DIN 69893-1)

HSK - A

$\nabla \leq 0,005$

G6,3  
 15.000 min<sup>-1</sup>

Bestell-Nr. Order no. Référence	HSK	MK MT CM	M	A	D
A50.08.01	HSK-A 50	1	M6	100	25
A50.08.02	HSK-A 50	2	M10	120	32
A50.08.03	HSK-A 50	3	M12	140	40
A63.08.01	HSK-A 63	1	M6	100	25
A63.08.02	HSK-A 63	2	M10	120	32
A63.08.03	HSK-A 63	3	M12	140	40
A63.08.04	HSK-A 63	4	M16	160	48
A80.08.01	HSK-A 80	1	M6	110	25
A80.08.02	HSK-A 80	2	M10	120	32
A80.08.03	HSK-A 80	3	M12	150	40
A80.08.04	HSK-A 80	4	M16	170	48
A100.08.01	HSK-A 100	1	M6	110	25
A100.08.02	HSK-A 100	2	M10	120	32
A100.08.03	HSK-A 100	3	M12	150	40
A100.08.04	HSK-A 100	4	M16	170	48
A100.08.05	HSK-A 100	5	M20	200	63



**Lieferumfang:** Mit eingebauter Fräseranzugsschraube  
**Delivery:** With built-in tightening bolt  
**Livraison:** Avec vis de serrage montée





Quick change tapping chucks with length compensation on compression and expansion

Mandrins de taraudage à changement rapide avec compensation longitudinale à la compression et traction



**Verwendung:**

Zur Aufnahme von Schnellwechsel-Ein-sätzen für Gewindebohrer.

**Application:**

For the chucking of quick change adaptors for taps.

**Application:**

Pour le serrage d'adaptateurs porte-tarands à changement rapide.

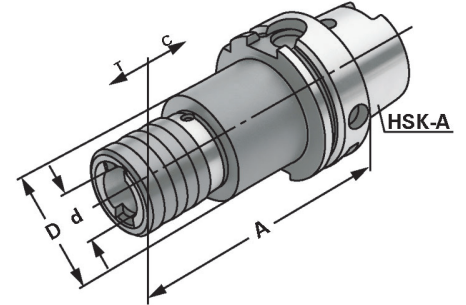

ISO 12164-1  
(DIN 69893-1)

HSK - A



5

Bestell-Nr. Order no. Référence	HSK	Spannbereich Capacity Capacité	Größe Size Taille	A	D	d	C	T
A32.16.12	HSK-A 32	M3 - M14	1	80	41	19	7	7
A40.16.12	HSK-A 40	M3 - M14	1	80	41	19	7	7
A40.16.20	HSK-A 40	M5 - M22	2	103	60	19	10	10
A50.16.12	HSK-A 50	M3 - M14	1	72	38	19	7	7
A50.16.20	HSK-A 50	M5 - M22	2	110	54	31	12	12
A63.16.12	HSK-A 63	M3 - M14	1	102	50	19	7	7
A63.16.20	HSK-A 63	M5 - M22	2	140	54	31	12	12
A63.16.36	HSK-A 63	M14 - M36	3	210	86	48	17,5	17,5
A80.16.12	HSK-A 80	M3 - M14	1	72	41	19	7	7
A80.16.20	HSK-A 80	M5 - M22	2	108	60	31	10	10
A80.16.36	HSK-A 80	M14 - M36	3	141	86	48	17,5	17,5
A100.16.12	HSK-A 100	M3 - M14	1	112	38	19	7	7
A100.16.20	HSK-A 100	M5 - M22	2	148	54	31	12	12
A100.16.36	HSK-A 100	M14 - M36	3	210	86	48	17,5	17,5

**Hinweis:** Für Bearbeitungszentren ohne Synchronspindel.  
**Note:** For machining centres without synchronous spindle.  
**Observation:** Pour centres d'usinage sans broche synchrone.





Quick change tapping chucks without length compensation on compression and expansion  
 Mandrins de taraudage à changement rapide sans compensation longitudinale à la compression et traction



**Verwendung:**  
 Zur Aufnahme von Schnellwechsel-Ein-  
 sätzen für Gewindebohrer.  
**Application:**  
 For the chucking of quick change adaptors  
 for taps.  
**Application:**  
 Pour le serrage d'adaptateurs porte-  
 tarauds à changement rapide.

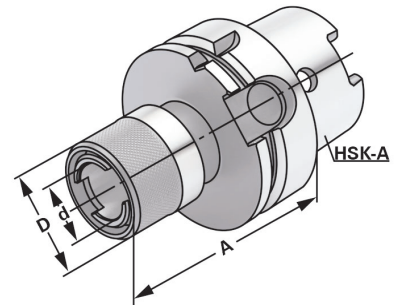

ISO 12164-1  
 (DIN 69893-1)

HSK - A



Bestell-Nr. Order no. Référence	HSK	Spannbereich Capacity Capacité	Größe Size Taille	A	D	d
A50.16.12.1	HSK-A 50	M3 - M14	1	65	38	19
A50.16.20.1	HSK-A 50	M5 - M22	2	100	54	31
A63.16.12.1	HSK-A 63	M3 - M14	1	65	38	19
A63.16.20.1	HSK-A 63	M5 - M22	2	100	54	31
A100.16.12.1	HSK-A 100	M3 - M14	1	80	38	19
A100.16.20.1	HSK-A 100	M5 - M22	2	90	54	31
A100.16.36.1	HSK-A 100	M14 - M36	3	130	86	48



**Hinweis:** Für Bearbeitungszentren mit Synchronspindel.  
**Note:** For machining centres with synchronous spindle.  
**Observation:** Pour centres d'usinage avec broche synchrone.

**Gewuchtete Ausführung**



Balanced type  
 Type équilibré

Bestell-Nr. Order no. Référence	Abmessung Size Dimension
---------------------------------------	--------------------------------

Wuchten auf G 2,5 von vorgewuchteten  
 Kemmler-Werkzeugen  
 Balancing at G 2.5 of pre-balanced Kemmler-tools  
 Equilibrage sur G 2,5 d'outils Kemmler pré-équilibrés

W25 **Ohne Wuchtprotokoll**  
 Without balancing report  
 Sans protocole d'équilibrage

W25.2 **Mit Wuchtprotokoll**  
 With balancing report  
 Avec protocole d'équilibrage

Wuchten von nicht vorgewuchteten Werkzeugen  
 Balancing of unbalanced tools  
 Equilibrage d'outils non-équilibrés

W25.1 **Ohne Wuchtprotokoll**  
 Without balancing report  
 Sans protocole d'équilibrage







Tapping chucks for synchronisation for collets DIN 6499 (ISO 15488) ER-system

Mandrins de taraudage pour synchronisation pour pinces DIN 6499 (ISO 15488) système ER

**Verwendung:**

Für Bearbeitungszentren mit Synchronspindel.

**Application:**

For machining centres with synchronous spindle.

**Application:**

Pour centres d'usinage avec broche synchrone.

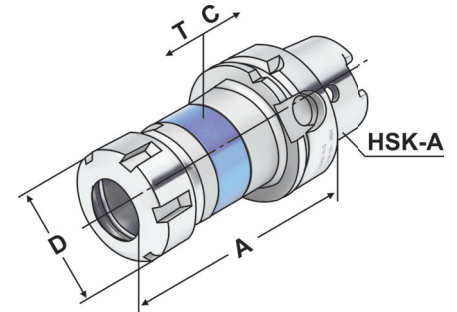
ISO 12164-1  
(DIN 69893-1)

HSK - A

 $\nabla \leq 0,060$ G6,3  
15.000 min<sup>-1</sup>

5

Bestell-Nr. Order no. Référence	HSK	Spannbereich Capacity Capacité	A	D	T	C
A40.16.02.10	HSK-A 40	M3 - M12 (ER 16)	87	28	0,5	0,5
A40.16.02.13	HSK-A 40	M3 - M16 (ER 20)	93	34	0,5	0,5
A50.16.02.10	HSK-A 50	M3 - M12 (ER 16)	87	28	0,5	0,5
A50.16.02.13	HSK-A 50	M3 - M16 (ER 20)	88	34	0,5	0,5
A50.16.02.16	HSK-A 50	M3 - M20 (ER 25)	92	42	0,5	0,5
A50.16.02.20	HSK-A 50	M3 - M27 (ER 32)	116	50	0,5	0,5
A63.16.02.10 <sup>1</sup>	HSK-A 63	M3 - M12 (ER 16) SW25	93	28	0,5	0,5
A63.16.02.10.M <sup>2</sup>	HSK-A 63	M3 - M12 (ER 16) Mini	93	22	0,5	0,5
A63.16.02.10.1.M <sup>2</sup>	HSK-A 63	M3 - M12 (ER 16) Mini	100	22	0,5	0,5
A63.16.02.13	HSK-A 63	M3 - M16 (ER 20)	94	34	0,5	0,5
A63.16.02.16	HSK-A 63	M3 - M20 (ER 25)	98	42	0,5	0,5
A63.16.02.20	HSK-A 63	M3 - M27 (ER 32)	108	50	0,5	0,5
A63.16.02.26	HSK-A 63	M3 - M33 (ER 40)	133,5	63	0,5	0,5
A80.16.02.13	HSK-A 80	M3 - M16 (ER 20)	100	34	0,5	0,5
A80.16.02.16	HSK-A 80	M3 - M20 (ER 25)	105	42	0,5	0,5
A80.16.02.20	HSK-A 80	M3 - M27 (ER 32)	110,5	50	0,5	0,5
A80.16.02.26	HSK-A 80	M3 - M33 (ER 40)	131	63	0,5	0,5
A100.16.02.10 <sup>1</sup>	HSK-A 100	M3 - M12 (ER 16) SW25	100	28	0,5	0,5
A100.16.02.10.M <sup>2</sup>	HSK-A 100	M3 - M12 (ER 16) Mini	100	22	0,5	0,5
A100.16.02.10.1.M <sup>2</sup>	HSK-A 100	M3 - M12 (ER 16) Mini	106	22	0,5	0,5
A100.16.02.13	HSK-A 100	M3 - M16 (ER 20)	101	34	0,5	0,5
A100.16.02.16	HSK-A 100	M3 - M20 (ER 25)	105	42	0,5	0,5
A100.16.02.20	HSK-A 100	M3 - M27 (ER 32)	110	50	0,5	0,5
A100.16.02.20.1	HSK-A 100	M3 - M27 (ER 32)	160	50	0,5	0,5
A100.16.02.20.2	HSK-A 100	M3 - M27 (ER 32)	190	50	0,5	0,5
A100.16.02.26	HSK-A 100	M3 - M33 (ER 40)	136	63	0,5	0,5

**Lieferumfang:** Mit gewichteter Spannmutter  
**Delivery:** With balanced clamping nut  
**Livraison:** Avec écrou de serrage équilibré

<sup>1</sup> Sechskantmutter  
<sup>1</sup> Hexagonal clamping nut  
<sup>1</sup> Écrous hexagonal

<sup>2</sup> Minimutter  
<sup>2</sup> Mini nut  
<sup>2</sup> Écrous mini





**Verwendung:**  
Zur Aufnahme von allen nach DIN 6595 genormten Vollbohrern mit Zylinderschaft.

**Application:**  
For all solid drills with cylindrical shank according to DIN 6595.

**Application:**  
Pour le serrage de forets à queue cylindrique suivant DIN 6595.

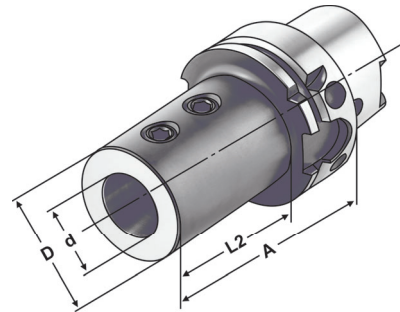

ISO 12164-1 (DIN 69893-1)    HSK - A     $\nabla \leq 0,005$     G6,3 15.000 min<sup>-1</sup>

Bestell-Nr. Order no. Référence	HSK	d	A	D	L2
A63.51.20	HSK-A 63	20	80	40	54
A63.51.25	HSK-A 63	25	90	45	59
A63.51.32	HSK-A 63	32	90	52	63
A63.51.40	HSK-A 63	40	105	63	73



**Lieferumfang:** Mit Spannschrauben  
**Delivery:** With clamping screws  
**Livraison:** Avec vis de serrage





**Verwendung:**  
Zur Aufnahme von Werkzeugen mit Zylinderschaft.

**Application:**  
For mounting tools with straight shanks.

**Application:**  
Pour le serrage d'outils avec queue cylindrique.

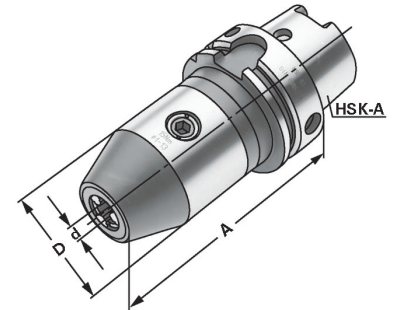

ISO 12164-1  
(DIN 69893-1)

HSK - A

$\nabla \leq 0,030$

G6,3  
15.000 min<sup>-1</sup>

14.04

5

Bestell-Nr. Order no. Référence	HSK	Spannbereich Capacity Capacité	A	D
A32.15.08	HSK-A 32	0 – 8	90	36
A40.15.08	HSK-A 40	0 – 8	90	36
A40.15.13	HSK-A 40	1,0 – 13	121	50
A40.15.16	HSK-A 40	2,5 – 16	126	50
A50.15.08	HSK-A 50	0 – 8	90	36
A50.15.13	HSK-A 50	1,0 – 13	116	50
A50.15.16	HSK-A 50	2,5 – 16	116	50
A63.15.08	HSK-A 63	0 – 8	85	36
A63.15.13	HSK-A 63	1,0 – 13	104	50
A63.15.16	HSK-A 63	2,5 – 16	109	50
A80.15.13	HSK-A 80	1,0 – 13	109	50
A80.15.16	HSK-A 80	2,5 – 16	114	50
A100.15.13	HSK-A 100	1,0 – 13	107	50
A100.15.16	HSK-A 100	2,5 – 16	112	50

**Hinweis:** Hohe Präzision und Rundlaufgenauigkeit von  $\leq 0,03$  mm. Sichere Spannung des Werkzeuges durch mechanische Spannkraftverstärkung. Kein selbständiges Lösen der Spannung während der Bearbeitung bei Links- oder Rechtslauf, sowie bei Spindelstop. Spannen und Lösen mit Sechskantschlüssel.

**Note:** High precision and accurate concentricity of  $\leq 0.03$  mm. Secure gripping of the tool through mechanical amplification of the clamping force. No automatic slackening of the clamping force while machining with either clockwise or counter clockwise rotation or on spindle stop. Clamping and releasing effected by means of an Allen wrench.

**Observation:** Précision élevée et exactitude de circularité de  $\leq 0,03$  mm. Serrage sûr de l'outil grâce à l'amplification de la force de serrage. Pas de desserrage intempestif en cours d'usinage lors de la rotation la gauche ou la droite, de même qu'en cas d'arrêt de la broche. Serrage et desserrage en utilisant un clé sur à fourche.

**Lieferumfang:** Mit Spannschlüssel  
**Delivery:** With wrench  
**Livraison:** Avec clé de serrage

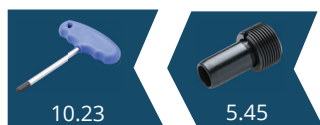



**Verwendung:**  
Zur Herstellung von Sonderwerkzeugen.

**Application:**  
*For the manufacturing of special tools.*

**Application:**  
Pour la fabrication d'outils spéciaux.

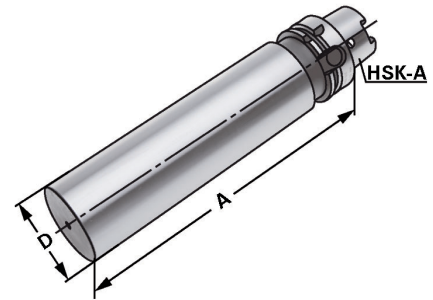
 ISO 12164-1  
 (DIN 69893-1)

HSK - A

 14.04

Bestell-Nr. Order no. Référence	HSK	D	A
A32.17.25	HSK-A 32	32,5	100
A40.17.40	HSK-A 40	40,5	160
A50.17.50	HSK-A 50	50,5	200
A63.17.63	HSK-A 63	63,5	250
A63.17.80	HSK-A 63	80,0	250
A80.17.80	HSK-A 80	80,5	250
A100.17.97	HSK-A 100	97,5	250

5

**Ausführung:** Kegel und Bund gehärtet und geschliffen. Schaft weich zur weiteren Bearbeitung.  
**Version:** *Cone and flange hardened and grinded. Soft body for later processing.*  
**Version:** Cône et collerette durcis et rectifiés. Corps doux pour un usinage ultérieur.



**Verwendung:**  
Zur Aufnahme von Werkzeugen mit Zylinderschaft nach DIN 1835 Form A+B+E und DIN 6535 Form HB+HE (größer Ø 20 mm nur mit Reduzierung).

**Application:**  
For mounting straight-shank tools acc. DIN 1835 form A+B+E and DIN 6535 form HB+HE (larger than Ø 20 mm only with reduction sleeve).

**Application:**  
Pour le serrage d'outils avec queue cylindrique suivant DIN 1835 forme A+B+E et DIN 6535 forme HB+HE (à partir de Ø 20 mm seulement avec réduction).

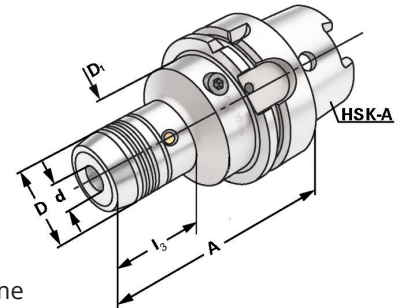

ISO 12164-1  
(DIN 69893-1)

HSK - A

$\nabla \leq 0,003$

G6,3  
15.000 min<sup>-1</sup>



5

Bestell-Nr. Order no. Référence	HSK	d	A	D	D <sub>1</sub>	l <sub>1</sub>	l <sub>2</sub>	l <sub>3</sub>
A32.H06	HSK-A 32	6	80	26	26	37	10	20
A32.H08	HSK-A 32	8	80	28	26	37	10	35
A32.H10	HSK-A 32	10	85	30	26	42	10	35
A32.H12	HSK-A 32	12	90	32	26	47	10	35
A32.H14	HSK-A 32	14	95	34	26	47	10	45
A32.H16	HSK-A 32	16	100	38	26	52	10	45
A32.H20	HSK-A 32	20	100	42	42	52	10	45
<hr/>								
A40.H06	HSK-A 40	6	80	26	34	37	10	45
A40.H08	HSK-A 40	8	80	28	34	37	10	44
A40.H10	HSK-A 40	10	85	30	34	42	10	44
A40.H12	HSK-A 40	12	90	32	34	47	10	43
A40.H14	HSK-A 40	14	90	34	34	47	10	41
A40.H16	HSK-A 40	16	90	38	34	52	10	38
A40.H18	HSK-A 40	18	90	40	34	52	10	38
A40.H20	HSK-A 40	20	90	42	34	52	10	16
<hr/>								
A50.H06	HSK-A 50	6	80	26	42	37	10	45
A50.H08	HSK-A 50	8	80	28	42	37	10	44
A50.H10	HSK-A 50	10	85	30	42	42	10	44
A50.H12	HSK-A 50	12	90	32	42	47	10	43
A50.H14	HSK-A 50	14	90	34	42	47	10	41
A50.H16	HSK-A 50	16	95	38	42	52	10	43
A50.H18	HSK-A 50	18	95	40	42	52	10	43
A50.H20	HSK-A 50	20	100	42	42	52	10	26
A50.H25	HSK-A 50	25	120	50	42	58	10	26

**Lieferumfang:** Mit Spannschlüssel  
**Delivery:** With wrench  
**Livraison:** Avec clé de serrage

l<sub>1</sub> = max. Einstecktiefe  
l<sub>1</sub> = max. clamping depth  
l<sub>1</sub> = max. profondeur d'insertion

l<sub>2</sub> = max. Verstellweg  
l<sub>2</sub> = max. length adjustment range  
l<sub>2</sub> = max. course de réglage

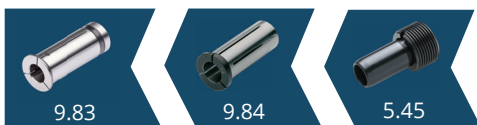



**Verwendung:**  
Zur Aufnahme von Werkzeugen mit Zylinderschaft nach DIN 1835 Form A+B+E und DIN 6535 Form HB+HE (größer Ø 20 mm nur mit Reduzierung).

**Application:**  
For mounting straight-shank tools acc. DIN 1835 form A+B+E and DIN 6535 form HB+HE (larger than Ø 20 mm only with reduction sleeve).

**Application:**  
Pour le serrage d'outils avec queue cylindrique suivant DIN 1835 forme A+B+E et DIN 6535 forme HB+HE (à partir de Ø 20 mm seulement avec réduction).

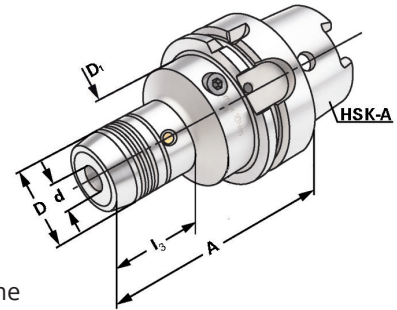

ISO 12164-1 (DIN 69893-1)    HSK - A     $\lambda \leq 0,003$     G6,3 15.000 min<sup>-1</sup>



Bestell-Nr. Order no. Référence	HSK	d	A	D	D <sub>1</sub>	l <sub>1</sub>	l <sub>2</sub>	l <sub>3</sub>
A63.H06	HSK-A 63	6	80	26	50	37	10	47
A63.H08	HSK-A 63	8	80	28	50	37	10	47
A63.H10	HSK-A 63	10	85	30	50	42	10	46
A63.H12	HSK-A 63	12	90	32	50	47	10	46
A63.H14	HSK-A 63	14	90	34	50	47	10	44
A63.H16	HSK-A 63	16	95	38	50	52	10	43
A63.H18	HSK-A 63	18	95	40	50	52	10	43
A63.H20	HSK-A 63	20	100	42	50	52	10	42
A63.H25	HSK-A 63	25	120	50	50	58	10	26
A63.H32	HSK-A 63	32	125	60	50	62	10	42
A63.H06.1	HSK-A 63	6	150	26	50	37	10	47
A63.H08.1	HSK-A 63	8	150	28	50	37	10	46
A63.H10.1	HSK-A 63	10	150	30	50	42	10	46
A63.H12.1	HSK-A 63	12	150	32	50	47	10	45
A63.H14.1	HSK-A 63	14	150	34	50	47	10	45
A63.H16.1	HSK-A 63	16	150	38	50	52	10	43,5
A63.H18.1	HSK-A 63	18	150	40	50	52	10	43
A63.H20.1	HSK-A 63	20	150	42	50	52	10	42
A63.H25.1	HSK-A 63	25	150	50	50	58	10	-
A63.H06.2	HSK-A 63	6	200	26	50	37	10	47
A63.H08.2	HSK-A 63	8	200	28	50	37	10	46
A63.H10.2	HSK-A 63	10	200	30	50	42	10	46
A63.H12.2	HSK-A 63	12	200	32	50	47	10	45
A63.H14.2	HSK-A 63	14	200	34	50	47	10	45
A63.H16.2	HSK-A 63	16	200	38	50	52	10	43,5
A63.H18.2	HSK-A 63	18	200	40	50	52	10	43
A63.H20.2	HSK-A 63	20	200	42	50	52	10	42
A63.H25.2	HSK-A 63	25	200	50	50	58	10	-

**Lieferumfang:** Mit Spannschlüssel  
**Delivery:** With wrench  
**Livraison:** Avec clé de serrage

l<sub>1</sub> = max. Einstecktiefe    l<sub>2</sub> = max. Verstellweg  
l<sub>1</sub> = max. clamping depth    l<sub>2</sub> = max. length adjustment range  
l<sub>1</sub> = max. profondeur d'insertion    l<sub>2</sub> = max. course de réglage

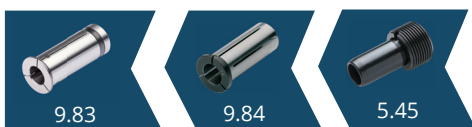



**Verwendung:**  
Zur Aufnahme von Werkzeugen mit Zylinderschaft nach DIN 1835 Form A+B+E und DIN 6535 Form HB+HE (größer Ø 20 mm nur mit Reduzierung).

**Application:**  
For mounting straight-shank tools acc. DIN 1835 form A+B+E and DIN 6535 form HB+HE (larger than Ø 20 mm only with reduction sleeve).

**Application:**  
Pour le serrage d'outils avec queue cylindrique suivant DIN 1835 forme A+B+E et DIN 6535 forme HB+HE (à partir de Ø 20 mm seulement avec réduction).

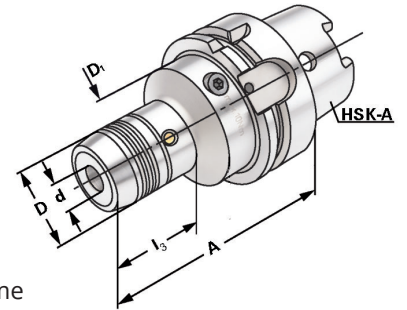

ISO 12164-1  
(DIN 69893-1)

HSK - A

$\nabla \leq 0,003$

G6,3  
15.000 min<sup>-1</sup>

14.04

5

Bestell-Nr. Order no. Référence	HSK	d	A	D	D <sub>1</sub>	l <sub>1</sub>	l <sub>2</sub>	l <sub>3</sub>
A80.H06	HSK-A 80	6	85	26	56	37	10	54
A80.H08	HSK-A 80	8	85	28	56	37	10	53
A80.H10	HSK-A 80	10	90	30	56	42	10	53
A80.H12	HSK-A 80	12	95	32	56	47	10	52
A80.H14	HSK-A 80	14	95	34	56	47	10	51
A80.H16	HSK-A 80	16	100	38	56	52	10	50
A80.H18	HSK-A 80	18	100	40	56	52	10	50
A80.H20	HSK-A 80	20	105	42	56	52	10	49
A80.H25	HSK-A 80	25	115	50	56	58	10	62
A80.H32	HSK-A 80	32	120	60	56	62	10	26
A100.H06	HSK-A 100	6	85	26	63	37	10	56
A100.H08	HSK-A 100	8	85	28	63	37	10	56
A100.H10	HSK-A 100	10	90	30	63	42	10	55
A100.H12	HSK-A 100	12	95	32	63	47	10	55
A100.H14	HSK-A 100	14	95	34	63	47	10	53
A100.H16	HSK-A 100	16	100	38	63	52	10	53
A100.H18	HSK-A 100	18	100	40	63	52	10	52
A100.H20	HSK-A 100	20	105	42	63	52	10	51
A100.H25	HSK-A 100	25	115	50	63	58	10	64
A100.H32	HSK-A 100	32	120	60	63	62	10	61
A100.H06.1	HSK-A 100	6	150	26	50	37	10	56
A100.H08.1	HSK-A 100	8	150	28	50	37	10	55,5
A100.H10.1	HSK-A 100	10	150	30	50	42	10	55
A100.H12.1	HSK-A 100	12	150	32	50	47	10	54,5
A100.H14.1	HSK-A 100	14	150	34	50	47	10	53
A100.H16.1	HSK-A 100	16	150	38	50	52	10	52,5
A100.H18.1	HSK-A 100	18	150	40	50	52	10	52
A100.H20.1	HSK-A 100	20	150	42	50	52	10	51
A100.H25.1	HSK-A 100	25	150	50	50	58	10	-
A100.H32.1	HSK-A 100	32	150	60	60	62	10	-

**Lieferumfang:** Mit Spannschlüssel  
**Delivery:** With wrench  
**Livraison:** Avec clé de serrage

l<sub>1</sub> = max. Einstecktiefe  
l<sub>1</sub> = max. clamping depth  
l<sub>1</sub> = max. profondeur d'insertion

l<sub>2</sub> = max. Verstellweg  
l<sub>2</sub> = max. length adjustment range  
l<sub>2</sub> = max. course de réglage



**Verwendung:**  
Zur Aufnahme von Werkzeugen mit Zylinderschaft nach DIN 1835 Form A+B+E und DIN 6535 Form HB+HE (größer Ø 20 mm nur mit Reduzierung).

**Application:**  
For mounting straight-shank tools acc. DIN 1835 form A+B+E and DIN 6535 form HB+HE (larger than Ø 20 mm only with reduction sleeve).

**Application:**  
Pour le serrage d'outils avec queue cylindrique suivant DIN 1835 forme A+B+E et DIN 6535 forme HB+HE (à partir de Ø 20 mm seulement avec réduction).

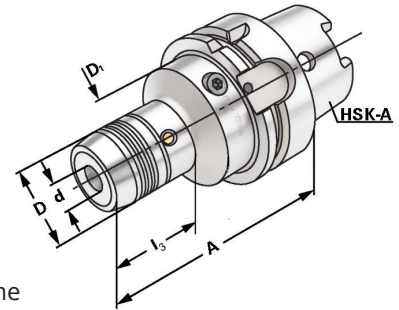

ISO 12164-1 (DIN 69893-1) HSK - A  $\nabla \leq 0,003$  G6,3 15.000 min<sup>-1</sup>



Bestell-Nr. Order no. Référence	HSK	d	A	D	D <sub>1</sub>	l <sub>1</sub>	l <sub>2</sub>	l <sub>3</sub>
A100.H06.2	HSK-A 100	6	200	26	50	37	10	56
A100.H08.2	HSK-A 100	8	200	28	50	37	10	55,5
A100.H10.2	HSK-A 100	10	200	30	50	42	10	55
A100.H12.2	HSK-A 100	12	200	32	50	47	10	54,5
A100.H14.2	HSK-A 100	14	200	34	50	47	10	53
A100.H16.2	HSK-A 100	16	200	38	50	52	10	52,5
A100.H18.2	HSK-A 100	18	200	40	50	52	10	52
A100.H20.2	HSK-A 100	20	200	42	50	52	10	51
A100.H25.2	HSK-A 100	25	200	50	50	58	10	-
A100.H32.2	HSK-A 100	32	200	60	60	62	10	-

**Lieferumfang:** Mit Spannschlüssel  
**Delivery:** With wrench  
**Livraison:** Avec clé de serrage

l<sub>1</sub> = max. Einstecktiefe  
l<sub>1</sub> = max. clamping depth  
l<sub>1</sub> = max. profondeur d'insertion

l<sub>2</sub> = max. Verstellweg  
l<sub>2</sub> = max. length adjustment range  
l<sub>2</sub> = max. course de réglage

**Gewuchtete Ausführung**

Balanced type  
Type équilibré

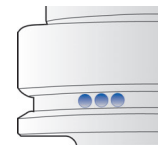

Bestell-Nr. Order no. Référence	Abmessung Size Dimension
---------------------------------------	--------------------------------

- Wuchten auf G 2,5 von vorgewuchteten Kemmler-Werkzeugen**  
Balancing at G 2.5 of pre-balanced Kemmler-tools  
Equilibrage sur G 2,5 d'outils Kemmler pré-équilibrés
- W25 **Ohne Wuchtprotokoll**  
Without balancing report  
Sans protocole d'équilibrage
  - W25.2 **Mit Wuchtprotokoll**  
With balancing report  
Avec protocole d'équilibrage
- Wuchten von nicht vorgewuchteten Werkzeugen**  
Balancing of unbalanced tools  
Equilibrage d'outils non-équilibrés
- W25.1 **Ohne Wuchtprotokoll**  
Without balancing report  
Sans protocole d'équilibrage

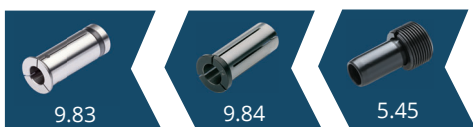



*Shrink chucks 4,5° for mounting of solid carbide and HSS-tool shanks**Mandrins de frettage 4,5° pour le serrage de queues d'outils carbures de type HM et HSS***Verwendung:**

Zur Aufnahme von Werkzeugen mit Zylinderschaft.

**Application:***For mounting straight-shank tools.***Application:**

Pour le serrage d'outils avec queue cylindrique.

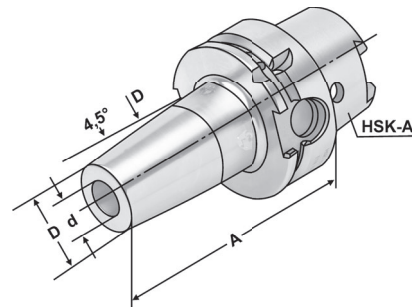
ISO 12164-1  
(DIN 69893-1)

HSK - A

 $\lambda \leq 0,003$ G2,5  
25.000 min<sup>-1</sup>

5

Bestell-Nr. Order no. Référence	HSK	d	A	D	D <sub>1</sub>	l <sub>1</sub>	l <sub>2</sub>
A32.70.03	HSK-A 32	3	60	11	15	10	-
A32.70.04	HSK-A 32	4	60	14	15	20	5
A32.70.05	HSK-A 32	5	60	16	15	20	5
A32.70.06	HSK-A 32	6	70	21	27	36	10
A32.70.08	HSK-A 32	8	70	21	27	36	10
A32.70.10	HSK-A 32	10	70	24	29	42	10
A32.70.12	HSK-A 32	12	90	24	29	47	10
A32.70.14	HSK-A 32	14	90	27	34	47	10
A32.70.16	HSK-A 32	16	90	27	34	50	10
A32.70.20	HSK-A 32	20	100	33	40	52	10
A40.70.03	HSK-A 40	3	80	11	15	10	-
A40.70.04	HSK-A 40	4	80	14	22	20	5
A40.70.05	HSK-A 40	5	80	16	22	20	5
A40.70.06	HSK-A 40	6	80	21	27	36	10
A40.70.08	HSK-A 40	8	80	21	27	36	10
A40.70.10	HSK-A 40	10	80	24	32	42	10
A40.70.12	HSK-A 40	12	90	24	32	47	10
A40.70.14	HSK-A 40	14	90	27	34	47	10
A40.70.16	HSK-A 40	16	90	27	34	50	10
A40.70.18	HSK-A 40	18	95	33	42	50	10
A40.70.20	HSK-A 40	20	100	33	42	52	10
A40.70.25	HSK-A 40	25	100	44	51	58	10

**Für Ø 3, 4 und 5 mm nur Hartmetallschäfte verwenden!***For Ø 3, 4 and 5 mm only solid carbide tool shanks must be used!*

Pour Ø 3, 4 et 5 mm il faut seulement utiliser de queues d'outils carbures de type HM!

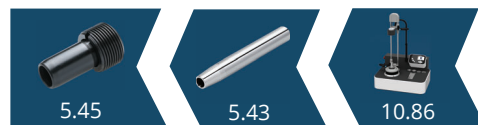
**Hinweis:** Aufnahme für Induktiv-, Kontakt- und Heißluftschumpfergeräte geeignet. Schafttoleranz bei Ø 3, 4 und 5 mm = h<sub>4</sub>, bei Ø 6 - Ø 32 mm = h<sub>6</sub>**Note:** *Toolholders suitable for induction-, contact- and hot air shrink units. Ø 3, 4, 5 with h<sub>4</sub>-tolerance and Ø 6 - Ø 32 with h<sub>6</sub>-tolerance***Observation:** Porte-outils convenables pour machines à frotter par induction, par contact, ou par air chaud. Ø 3, 4, 5 avec h<sub>4</sub>-tolerance et Ø 6 - Ø 32 avec h<sub>6</sub>-tolerancel<sub>1</sub> = max. Einstecktiefel<sub>1</sub> = max. clamping depthl<sub>1</sub> = max. profondeur d'insertionl<sub>2</sub> = max. Verstellwegl<sub>2</sub> = max. length adjustment rangel<sub>2</sub> = max. course de réglage

Shrink chucks 4,5° for mounting of solid carbide and HSS-tool shanks

Mandrins de frettage 4,5° pour le serrage de queues d'outils carbures de type HM et HSS



**Verwendung:**  
Zur Aufnahme von Werkzeugen mit Zylinderschaft.

**Application:**  
For mounting straight-shank tools.

**Application:**  
Pour le serrage d'outils avec queue cylindrique.

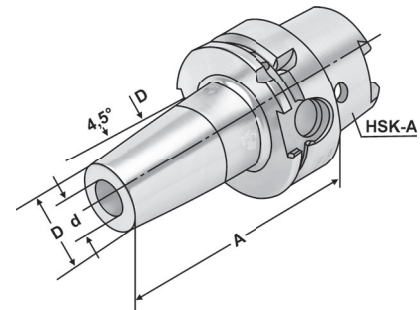

ISO 12164-1  
(DIN 69893-1)

HSK - A

$\nabla \leq 0,003$

G2,5  
25.000 min<sup>-1</sup>

Bestell-Nr. Order no. Référence	HSK	d	A	D	D <sub>1</sub>	l <sub>1</sub>	l <sub>2</sub>
A50.70.03	HSK-A 50	3	80	11	15	10	-
A50.70.04	HSK-A 50	4	80	14	22	20	5
A50.70.05	HSK-A 50	5	80	16	22	20	5
A50.70.06	HSK-A 50	6	80	21	27	36	10
A50.70.08	HSK-A 50	8	80	21	27	36	10
A50.70.10	HSK-A 50	10	85	24	32	42	10
A50.70.12	HSK-A 50	12	90	24	32	47	10
A50.70.14	HSK-A 50	14	90	27	34	47	10
A50.70.16	HSK-A 50	16	95	27	34	50	10
A50.70.18	HSK-A 50	18	95	33	42	50	10
A50.70.20	HSK-A 50	20	100	33	42	52	10
A50.70.25	HSK-A 50	25	115	44	53	58	10
A50.70.32	HSK-A 50	32	120	44	53	62	10
A50.70.06.1	HSK-A 50	6	120	21	27	20	10
A50.70.08.1	HSK-A 50	8	120	21	27	20	10
A50.70.10.1	HSK-A 50	10	120	24	32	36	10
A50.70.12.1	HSK-A 50	12	120	24	32	36	10
A50.70.14.1	HSK-A 50	14	120	27	34	41	10
A50.70.16.1	HSK-A 50	16	120	27	34	47	10
A50.70.18.1	HSK-A 50	18	120	33	42	47	10
A50.70.20.1	HSK-A 50	20	120	33	42	50	10
A50.70.03.2	HSK-A 50	3	160	11	15	10	-
A50.70.04.2	HSK-A 50	4	160	14	22	20	5
A50.70.05.2	HSK-A 50	5	160	16	22	20	5
A50.70.06.2	HSK-A 50	6	160	21	27	36	10
A50.70.08.2	HSK-A 50	8	160	21	27	36	10
A50.70.10.2	HSK-A 50	10	160	24	32	41	10
A50.70.12.2	HSK-A 50	12	160	24	32	47	10
A50.70.14.2	HSK-A 50	14	160	27	34	47	10
A50.70.16.2	HSK-A 50	16	160	27	34	50	10
A50.70.18.2	HSK-A 50	18	160	33	42	50	10
A50.70.20.2	HSK-A 50	20	160	33	42	52	10

**Hinweis:** Aufnahme für Induktiv-, Kontakt- und Heißluftschumpfergeräte geeignet.  
Schafttoleranz bei Ø 3, 4 und 5 mm = h<sub>4</sub>, bei Ø 6 – Ø 32 mm = h<sub>6</sub>

**Note:** Toolholders suitable for induction-, contact- and hot air shrink units.  
Ø 3, 4, 5 with h<sub>4</sub>-tolerance and Ø 6 – Ø 32 with h<sub>6</sub>-tolerance

**Observation:** Porte-outils convenables pour machines à frotter par induction,  
par contact, ou par air chaud.  
Ø 3, 4, 5 avec h<sub>4</sub>-tolerance et Ø 6 – Ø 32 avec h<sub>6</sub>-tolerance

l<sub>1</sub> = max. Einstecktiefe  
l<sub>1</sub> = max. clamping depth  
l<sub>1</sub> = max. profondeur d'insertion  
l<sub>2</sub> = max. Verstellweg  
l<sub>2</sub> = max. length adjustment range  
l<sub>2</sub> = max. course de réglage



Shrink chucks 4,5° for mounting of solid carbide and HSS-tool shanks

Mandrins de frettage 4,5° pour le serrage de queues d'outils carbures de type HM et HSS

**Verwendung:**

Zur Aufnahme von Werkzeugen mit Zylinderschaft.

**Application:**

For mounting straight-shank tools.

**Application:**

Pour le serrage d'outils avec queue cylindrique.

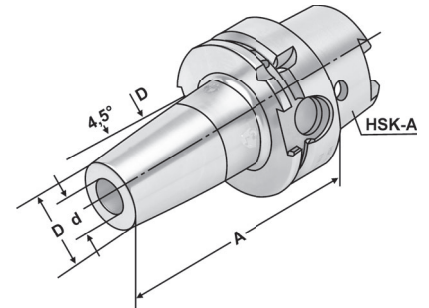
ISO 12164-1  
(DIN 69893-1)

HSK - A

 $\nabla \leq 0,003$ G2.5  
25.000 min<sup>-1</sup>

5

Bestell-Nr. Order no. Référence	HSK	d	A	D	D <sub>1</sub>	l <sub>1</sub>	l <sub>2</sub>
A63.70.03	HSK-A 63	3	80	11	15	10	-
A63.70.04	HSK-A 63	4	80	14	22	20	5
A63.70.05	HSK-A 63	5	80	16	22	20	5
A63.70.06	HSK-A 63	6	80	21	27	36	10
A63.70.08	HSK-A 63	8	80	21	27	36	10
A63.70.10	HSK-A 63	10	85	24	32	42	10
A63.70.12	HSK-A 63	12	90	24	32	47	10
A63.70.14	HSK-A 63	14	90	27	34	47	10
A63.70.16	HSK-A 63	16	95	27	34	50	10
A63.70.18	HSK-A 63	18	95	33	42	50	10
A63.70.20	HSK-A 63	20	100	33	42	52	10
A63.70.25	HSK-A 63	25	115	44	53	58	10
A63.70.32	HSK-A 63	32	120	44	53	61	10
A63.70.03.1	HSK-A 63	3	120	11	15	10	-
A63.70.04.1	HSK-A 63	4	120	14	22	20	5
A63.70.05.1	HSK-A 63	5	120	16	22	20	5
A63.70.06.1	HSK-A 63	6	120	21	27	36	10
A63.70.08.1	HSK-A 63	8	120	21	27	36	10
A63.70.10.1	HSK-A 63	10	120	24	32	42	10
A63.70.12.1	HSK-A 63	12	120	24	32	42	10
A63.70.14.1	HSK-A 63	14	120	27	34	47	10
A63.70.16.1	HSK-A 63	16	120	27	34	50	10
A63.70.18.1	HSK-A 63	18	120	33	42	50	10
A63.70.20.1	HSK-A 63	20	120	33	42	52	10
A63.70.25.1	HSK-A 63	25	120	44	53	58	10

**Für Ø 3, 4 und 5 mm nur Hartmetallschäfte verwenden!**

For Ø 3, 4 and 5 mm only solid carbide tool shanks must be used!

Pour Ø 3, 4 et 5 mm il faut seulement utiliser de queues d'outils carbures de type HM!

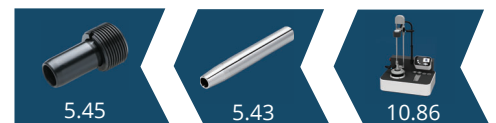
**Hinweis:** Aufnahme für Induktiv-, Kontakt- und Heißluftschumpfergeräte geeignet.  
Schafttoleranz bei Ø 3, 4 und 5 mm = h<sub>4</sub>, bei Ø 6 – Ø 32 mm = h<sub>6</sub>**Note:** Toolholders suitable for induction-, contact- and hot air shrink units.  
Ø 3, 4, 5 with h<sub>4</sub>-tolerance and Ø 6 – Ø 32 with h<sub>6</sub>-tolerance**Observation:** Porte-outils convenables pour machines à frotter par induction,  
par contact, ou par air chaud.  
Ø 3, 4, 5 avec h<sub>4</sub>-tolerance et Ø 6 – Ø 32 avec h<sub>6</sub>-tolerancel<sub>1</sub> = max. Einstecktiefel<sub>1</sub> = max. clamping depthl<sub>1</sub> = max. profondeur d'insertionl<sub>2</sub> = max. Verstellwegl<sub>2</sub> = max. length adjustment rangel<sub>2</sub> = max. course de réglage

Shrink chucks 4,5° for mounting of solid carbide and HSS-tool shanks

Mandrins de frettage 4,5° pour le serrage de queues d'outils carbures de type HM et HSS



**Verwendung:**  
Zur Aufnahme von Werkzeugen mit Zylinderschaft.

**Application:**  
For mounting straight-shank tools.

**Application:**  
Pour le serrage d'outils avec queue cylindrique.

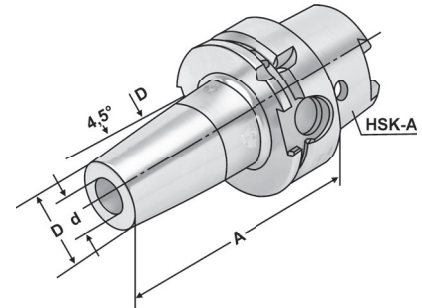

ISO 12164-1  
(DIN 69893-1)

HSK - A

$\nabla \leq 0,003$

G2,5  
25.000 min<sup>-1</sup>

Bestell-Nr. Order no. Référence	HSK	d	A	D	D <sub>1</sub>	l <sub>1</sub>	l <sub>2</sub>
A63.70.03.2	HSK-A 63	3	160	11	15	10	-
A63.70.04.2	HSK-A 63	4	160	14	22	20	5
A63.70.05.2	HSK-A 63	5	160	16	22	20	5
A63.70.06.2	HSK-A 63	6	160	21	27	36	10
A63.70.08.2	HSK-A 63	8	160	21	27	36	10
A63.70.10.2	HSK-A 63	10	160	24	32	41	10
A63.70.12.2	HSK-A 63	12	160	24	32	47	10
A63.70.14.2	HSK-A 63	14	160	27	34	47	10
A63.70.16.2	HSK-A 63	16	160	27	34	50	10
A63.70.18.2	HSK-A 63	18	160	33	42	50	10
A63.70.20.2	HSK-A 63	20	160	33	42	52	10
A63.70.25.2	HSK-A 63	25	160	44	53	58	10
A63.70.32.2	HSK-A 63	32	160	44	53	62	10
A63.70.06.3	HSK-A 63	6	200	21	27	36	10
A63.70.08.3	HSK-A 63	8	200	21	27	36	10
A63.70.10.3	HSK-A 63	10	200	24	32	41	10
A63.70.12.3	HSK-A 63	12	200	24	32	47	10
A63.70.16.3	HSK-A 63	16	200	27	34	50	10
A63.70.20.3	HSK-A 63	20	200	33	42	52	10
A63.70.25.3	HSK-A 63	25	200	44	53	58	
A63.70.32.3	HSK-A 63	32	200	44	53	62	10

Für Ø 3, 4 und 5 mm nur Hartmetallschäfte verwenden!

For Ø 3, 4 and 5 mm only solid carbide tool shanks must be used!

Pour Ø 3, 4 et 5 mm il faut seulement utiliser de queues d'outils carbures de type HM!

**Hinweis:** Aufnahme für Induktiv-, Kontakt- und Heißluftschumpfergeräte geeignet.  
Schafttoleranz bei Ø 3, 4 und 5 mm = h<sub>4</sub>, bei Ø 6 – Ø 32 mm = h<sub>6</sub>

**Note:** Toolholders suitable for induction-, contact- and hot air shrink units.  
Ø 3, 4, 5 with h<sub>4</sub>-tolerance and Ø 6 – Ø 32 with h<sub>6</sub>-tolerance

**Observation:** Porte-outils convenables pour machines à fretter par induction, par contact, ou par air chaud.  
Ø 3, 4, 5 avec h<sub>4</sub>-tolerance et Ø 6 – Ø 32 avec h<sub>6</sub>-tolerance

l<sub>1</sub> = max. Einstecktiefe      l<sub>2</sub> = max. Verstellweg  
l<sub>1</sub> = max. clamping depth      l<sub>2</sub> = max. length adjustment range  
l<sub>1</sub> = max. profondeur d'insertion      l<sub>2</sub> = max. course de réglage

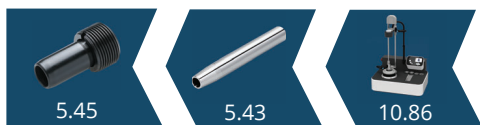



Shrink chucks 4,5° for mounting of solid carbide and HSS-tool shanks

Mandrins de frettage 4,5° pour le serrage de queues d'outils carbures de type HM et HSS

**Verwendung:**

Zur Aufnahme von Werkzeugen mit Zylinderschaft.

**Application:**

For mounting straight-shank tools.

**Application:**

Pour le serrage d'outils avec queue cylindrique.

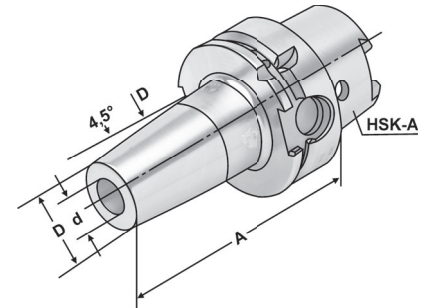
ISO 12164-1  
(DIN 69893-1)

HSK - A

 $\nabla \leq 0,003$ G2,5  
25.000 min<sup>-1</sup>

5

Bestell-Nr. Order no. Référence	HSK	d	A	D	D <sub>1</sub>	l <sub>1</sub>	l <sub>2</sub>
A80.70.04	HSK-A 80	4	80	14	22	20	5
A80.70.06	HSK-A 80	6	85	21	27	36	10
A80.70.08	HSK-A 80	8	85	21	27	36	10
A80.70.10	HSK-A 80	10	90	24	32	42	10
A80.70.12	HSK-A 80	12	95	24	32	47	10
A80.70.14	HSK-A 80	14	95	27	34	47	10
A80.70.16	HSK-A 80	16	100	27	34	50	10
A80.70.18	HSK-A 80	18	100	33	42	50	10
A80.70.20	HSK-A 80	20	105	33	42	52	10
A80.70.25	HSK-A 80	25	115	44	53	58	10
A80.70.32	HSK-A 80	32	120	44	53	61	10
A80.70.06.1	HSK-A 80	6	120	21	27	36	10
A80.70.08.1	HSK-A 80	8	120	21	27	36	10
A80.70.10.1	HSK-A 80	10	120	24	32	41	10
A80.70.12.1	HSK-A 80	12	120	24	32	47	10
A80.70.14.1	HSK-A 80	14	120	27	34	47	10
A80.70.06.2	HSK-A 80	6	160	21	27	36	10
A80.70.08.2	HSK-A 80	8	160	21	27	36	10
A80.70.10.2	HSK-A 80	10	160	24	32	41	10
A80.70.12.2	HSK-A 80	12	160	24	32	47	10
A80.70.14.2	HSK-A 80	14	160	27	34	47	10
A80.70.16.2	HSK-A 80	16	160	27	34	50	10
A80.70.18.2	HSK-A 80	18	160	33	42	50	10
A80.70.20.2	HSK-A 80	20	160	33	42	52	10
A80.70.25.2	HSK-A 80	25	160	44	53	58	10

**Für Ø 3, 4 und 5 mm nur Hartmetallschäfte verwenden!**

For Ø 3, 4 and 5 mm only solid carbide tool shanks must be used!

Pour Ø 3, 4 et 5 mm il faut seulement utiliser de queues d'outils carbures de type HM!

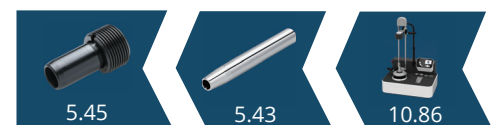
**Hinweis:** Aufnahme für Induktiv-, Kontakt- und Heißluftschumpfgeräte geeignet.  
Schafttoleranz bei Ø 3, 4 und 5 mm = h<sub>4</sub>, bei Ø 6 - Ø 32 mm = h<sub>6</sub>**Note:** Toolholders suitable for induction-, contact- and hot air shrink units.  
Ø 3, 4, 5 with h<sub>4</sub>-tolerance and Ø 6 - Ø 32 with h<sub>6</sub>-tolerance**Observation:** Porte-outils convenables pour machines à fretter par induction,  
par contact, ou par air chaud.  
Ø 3, 4, 5 avec h<sub>4</sub>-tolerance et Ø 6 - Ø 32 avec h<sub>6</sub>-tolerancel<sub>1</sub> = max. Einstecktiefel<sub>1</sub> = max. clamping depthl<sub>1</sub> = max. profondeur d'insertionl<sub>2</sub> = max. Verstellwegl<sub>2</sub> = max. length adjustment rangel<sub>2</sub> = max. course de réglage

Shrink chucks 4,5° for mounting of solid carbide and HSS-tool shanks

Mandrins de frettage 4,5° pour le serrage de queues d'outils carbures de type HM et HSS



**Verwendung:**  
Zur Aufnahme von Werkzeugen mit  
Zylinderschaft.

**Application:**  
For mounting straight-shank tools.

**Application:**  
Pour le serrage d'outils avec queue  
cylindrique.

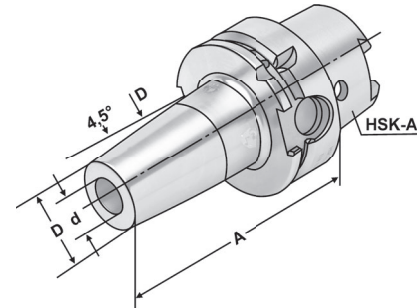

ISO 12164-1  
(DIN 69893-1)

HSK - A

$\nabla \leq 0,003$

G2,5  
25.000 min<sup>-1</sup>

Bestell-Nr. Order no. Référence	HSK	d	A	D	D <sub>1</sub>	l <sub>1</sub>	l <sub>2</sub>
A100.70.04	HSK-A 100	4	85	14	22	20	5
A100.70.05	HSK-A 100	5	85	16	22	20	5
A100.70.06	HSK-A 100	6	85	21	27	36	10
A100.70.08	HSK-A 100	8	85	21	27	36	10
A100.70.10	HSK-A 100	10	90	24	32	42	10
A100.70.12	HSK-A 100	12	95	24	32	47	10
A100.70.14	HSK-A 100	14	95	27	34	47	10
A100.70.16	HSK-A 100	16	100	27	34	50	10
A100.70.18	HSK-A 100	18	100	33	42	50	10
A100.70.20	HSK-A 100	20	105	33	42	52	10
A100.70.25	HSK-A 100	25	120	44	53	56	10
A100.70.32	HSK-A 100	32	120	44	53	62	10
A100.70.40	HSK-A 100	40	150	78	90	90	10
A100.70.50	HSK-A 100	50	150	78	90	90	10
A100.70.06.1	HSK-A 100	6	120	21	27	36	10
A100.70.08.1	HSK-A 100	8	120	21	27	36	10
A100.70.10.1	HSK-A 100	10	120	24	32	41	10
A100.70.12.1	HSK-A 100	12	120	24	32	47	10
A100.70.14.1	HSK-A 100	14	120	27	34	47	10
A100.70.16.1	HSK-A 100	16	120	27	34	50	10
A100.70.18.1	HSK-A 100	18	120	33	42	50	10
A100.70.20.1	HSK-A 100	20	120	33	42	52	10
A100.70.06.2	HSK-A 100	6	160	21	27	36	10
A100.70.08.2	HSK-A 100	8	160	21	27	36	10
A100.70.10.2	HSK-A 100	10	160	24	32	41	10
A100.70.12.2	HSK-A 100	12	160	24	32	47	10
A100.70.14.2	HSK-A 100	14	160	27	34	47	10
A100.70.16.2	HSK-A 100	16	160	27	34	50	10
A100.70.18.2	HSK-A 100	18	160	33	42	50	10
A100.70.20.2	HSK-A 100	20	160	33	42	52	10
A100.70.25.2	HSK-A 100	25	160	44	53	58	10
A100.70.32.2	HSK-A 100	32	160	44	53	62	10

**Hinweis:** Aufnahme für Induktiv-, Kontakt- und Heißluftschumpfgeräte geeignet.

**Note:** Toolholders suitable for induction-, contact- and hot air shrink units.

**Observation:** Porte-outils convenables pour machines à fretter par induction, par contact, ou par air chaud.

**l<sub>1</sub> = max. Einstecktiefe**

*l<sub>1</sub> = max. clamping depth*

*l<sub>1</sub> = max. profondeur d'insertion*

**l<sub>2</sub> = max. Verstellweg**

*l<sub>2</sub> = max. length adjustment range*

*l<sub>2</sub> = max. course de réglage*



Shrink chucks 4,5° for mounting of solid carbide and HSS-tool shanks

Mandrins de frettage 4,5° pour le serrage de queues d'outils carbures de type HM et HSS

**Verwendung:**

Zur Aufnahme von Werkzeugen mit Zylinderschaft.

**Application:**

For mounting straight-shank tools.

**Application:**

Pour le serrage d'outils avec queue cylindrique.

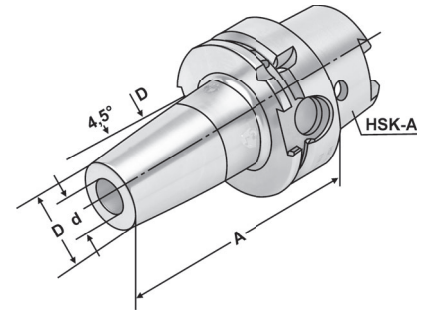
ISO 12164-1  
(DIN 69893-1)

HSK - A

 $\nabla \leq 0,003$ G2,5  
25.000 min<sup>-1</sup>

5

Bestell-Nr. Order no. Référence	HSK	d	A	D	D <sub>1</sub>	l <sub>1</sub>	l <sub>2</sub>
A100.70.06.3	HSK-A 100	6	200	21	27	36	10
A100.70.08.3	HSK-A 100	8	200	21	27	36	10
A100.70.10.3	HSK-A 100	10	200	24	32	41	10
A100.70.12.3	HSK-A 100	12	200	24	32	47	10
A100.70.14.3	HSK-A 100	14	200	27	34	47	10
A100.70.16.3	HSK-A 100	16	200	27	34	50	10
A100.70.18.3	HSK-A 100	18	200	33	42	50	10
A100.70.20.3	HSK-A 100	20	200	33	42	52	10
A100.70.25.3	HSK-A 100	25	200	44	53	58	10
A100.70.32.3	HSK-A 100	32	200	44	53	62	10
A100.70.06.4	HSK-A 100	6	250	21	27	36	10
A100.70.08.4	HSK-A 100	8	250	21	27	36	10
A100.70.10.4	HSK-A 100	10	250	24	32	41	10
A100.70.12.4	HSK-A 100	12	250	24	32	47	10
A100.70.14.4	HSK-A 100	14	250	27	34	47	10
A100.70.16.4	HSK-A 100	16	250	27	34	50	10

**Hinweis:** Aufnahme für Induktiv-, Kontakt- und Heißluftschumpfgeräte geeignet.  
Schafttoleranz bei Ø 3, 4 und 5 mm = h<sub>4</sub>, bei Ø 6 – Ø 32 mm = h<sub>6</sub>

**Note:** Toolholders suitable for induction-, contact- and hot air shrink units.  
Ø 3, 4, 5 with h<sub>4</sub>-tolerance and Ø 6 – Ø 32 with h<sub>6</sub>-tolerance

**Observation:** Porte-outils convenables pour machines à fretter par induction,  
par contact, ou par air chaud.  
Ø 3, 4, 5 avec h<sub>4</sub>-tolerance et Ø 6 – Ø 32 avec h<sub>6</sub>-tolerance

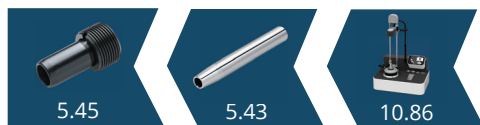
l<sub>1</sub> = max. Einstecktiefel<sub>1</sub> = max. clamping depthl<sub>1</sub> = max. profondeur d'insertionl<sub>2</sub> = max. Verstellwegl<sub>2</sub> = max. length adjustment rangel<sub>2</sub> = max. course de réglage

Shrink chucks 4,5° for mounting of solid carbide and HSS-tool shanks

Mandrins de frettage 4,5° pour le serrage de queues d'outils carbures de type HM et HSS



**Verwendung:**  
Zur Aufnahme von Werkzeugen mit Zylinderschaft.

**Application:**  
For mounting straight-shank tools.

**Application:**  
Pour le serrage d'outils avec queue cylindrique.

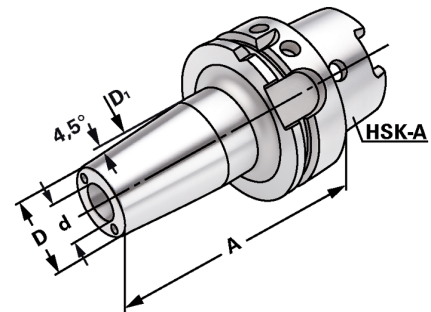

ISO 12164-1  
(DIN 69893-1)

HSK - A

$\nabla \leq 0,003$

G2,5  
25.000 min<sup>-1</sup>

Bestell-Nr. Order no. Référence	HSK	d	A	D	D <sub>1</sub>	l <sub>1</sub>	l <sub>2</sub>
A63.70.03.K	HSK-A 63	3	80	11	15	10	-
A63.70.04.K	HSK-A 63	4	80	14	22	20	5
A63.70.05.K	HSK-A 63	5	80	16	22	20	5
A63.70.06.K	HSK-A 63	6	80	21	27	36	10
A63.70.08.K	HSK-A 63	8	80	21	27	36	10
A63.70.10.K	HSK-A 63	10	85	24	32	42	10
A63.70.12.K	HSK-A 63	12	90	24	32	47	10
A63.70.14.K	HSK-A 63	14	90	27	34	47	10
A63.70.16.K	HSK-A 63	16	95	27	34	50	10
A63.70.18.K	HSK-A 63	18	95	33	42	50	10
A63.70.20.K	HSK-A 63	20	100	33	42	52	10
A63.70.25.K	HSK-A 63	25	115	44	53	58	10
A63.70.32.K	HSK-A 63	32	120	44	53	61	10
A63.70.03.1.K	HSK-A 63	3	120	11	15	10	-
A63.70.04.1.K	HSK-A 63	4	120	14	22	20	5
A63.70.05.1.K	HSK-A 63	5	120	16	22	20	5
A63.70.06.1.K	HSK-A 63	6	120	21	27	36	10
A63.70.08.1.K	HSK-A 63	8	120	21	27	36	10
A63.70.10.1.K	HSK-A 63	10	120	24	32	42	10
A63.70.12.1.K	HSK-A 63	12	120	24	32	47	10
A63.70.14.1.K	HSK-A 63	14	120	27	34	47	10
A63.70.16.1.K	HSK-A 63	16	120	27	34	50	10
A63.70.18.1.K	HSK-A 63	18	120	33	42	50	10
A63.70.20.1.K	HSK-A 63	20	120	33	42	52	10
A63.70.25.1.K	HSK-A 63	25	120	44	53	58	10

5

Für Ø 3, 4 und 5 mm nur Hartmetallschäfte verwenden!

For Ø 3, 4 and 5 mm only solid carbide tool shanks must be used!

Pour Ø 3, 4 et 5 mm il faut seulement utiliser de queues d'outils carbures de type HM!

**Hinweis:** Aufnahme für Induktiv-, Kontakt- und Heißluftschumpfgeräte geeignet.  
Schafttoleranz bei Ø 3, 4 und 5 mm = h<sub>4</sub>, bei Ø 6 – Ø 32 mm = h<sub>6</sub>

**Note:** Toolholders suitable for induction-, contact- and hot air shrink units.  
Ø 3, 4, 5 with h<sub>4</sub>-tolerance and Ø 6 – Ø 32 with h<sub>6</sub>-tolerance

**Observation:** Porte-outils convenables pour machines à fretter par induction, par contact, ou par air chaud.  
Ø 3, 4, 5 avec h<sub>4</sub>-tolerance et Ø 6 – Ø 32 avec h<sub>6</sub>-tolerance

l<sub>1</sub> = max. Einstecktiefe

l<sub>1</sub> = max. clamping depth

l<sub>1</sub> = max. profondeur d'insertion

l<sub>2</sub> = max. Verstellweg

l<sub>2</sub> = max. length adjustment range

l<sub>2</sub> = max. course de réglage





Shrink chucks 4,5° for mounting of solid carbide and HSS-tool shanks

Mandrins de frettage 4,5° pour le serrage de queues d'outils carbures de type HM et HSS

**Verwendung:**

Zur Aufnahme von Werkzeugen mit Zylinderschaft.

**Application:**

For mounting straight-shank tools.

**Application:**

Pour le serrage d'outils avec queue cylindrique.

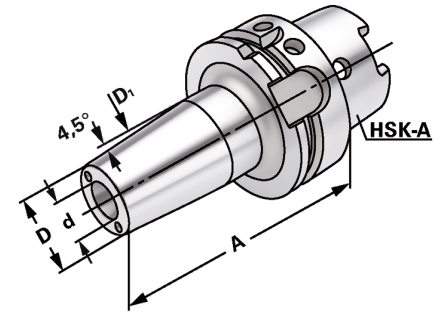
ISO 12164-1  
(DIN 69893-1)

HSK - A

 $\nabla \leq 0,003$ G2,5  
25.000 min<sup>-1</sup>

5

Bestell-Nr. Order no. Référence	HSK	d	A	D	D <sub>1</sub>	l <sub>1</sub>	l <sub>2</sub>
A63.70.06.2.K	HSK-A 63	6	160	21	27	36	10
A63.70.08.2.K	HSK-A 63	8	160	21	27	36	10
A63.70.10.2.K	HSK-A 63	10	160	24	32	42	10
A63.70.12.2.K	HSK-A 63	12	160	24	32	47	10
A63.70.14.2.K	HSK-A 63	14	160	27	34	47	10
A63.70.16.2.K	HSK-A 63	16	160	27	34	50	10
A63.70.18.2.K	HSK-A 63	18	160	33	42	50	10
A63.70.20.2.K	HSK-A 63	20	160	33	42	52	10
A63.70.25.2.K	HSK-A 63	25	160	44	53	58	10
A63.70.32.2.K	HSK-A 63	32	160	44	53	61	10
A100.70.05.K	HSK-A 100	5	80	16	22	20	5
A100.70.06.K	HSK-A 100	6	80	21	27	36	10
A100.70.08.K	HSK-A 100	8	80	21	27	36	10
A100.70.10.K	HSK-A 100	10	85	24	32	42	10
A100.70.12.K	HSK-A 100	12	90	24	32	47	10
A100.70.14.K	HSK-A 100	14	90	27	34	47	10
A100.70.16.K	HSK-A 100	16	95	27	34	50	10
A100.70.18.K	HSK-A 100	18	95	33	42	50	10
A100.70.20.K	HSK-A 100	20	100	33	42	52	10
A100.70.25.K	HSK-A 100	25	115	44	53	58	10
A100.70.32.K	HSK-A 100	32	120	44	53	61	10
A100.70.05.1.K	HSK-A 100	5	120	16	22	20	5
A100.70.06.1.K	HSK-A 100	6	120	21	27	36	10
A100.70.08.1.K	HSK-A 100	8	120	21	27	36	10
A100.70.10.1.K	HSK-A 100	10	120	24	32	42	10
A100.70.12.1.K	HSK-A 100	12	120	24	32	47	10
A100.70.14.1.K	HSK-A 100	14	120	27	34	47	10
A100.70.16.1.K	HSK-A 100	16	120	27	34	50	10
A100.70.18.1.K	HSK-A 100	18	120	33	42	50	10
A100.70.20.1.K	HSK-A 100	20	120	33	42	52	10
A100.70.25.1.K	HSK-A 100	25	120	44	53	58	10
A100.70.32.1.K	HSK-A 100	32	120	44	53	61	10

**Hinweis:** Aufnahme für Induktiv-, Kontakt- und Heißluftschumpfergeräte geeignet.Schafttoleranz bei Ø 3, 4 und 5 mm = h<sub>4</sub>, bei Ø 6 – Ø 32 mm = h<sub>6</sub>**Note:** Toolholders suitable for induction-, contact- and hot air shrink units.  
Ø 3, 4, 5 with h<sub>4</sub>-tolerance and Ø 6 – Ø 32 with h<sub>6</sub>-tolerance**Observation:** Porte-outils convenables pour machines à fretter par induction, par contact, ou par air chaud.Ø 3, 4, 5 avec h<sub>4</sub>-tolerance et Ø 6 – Ø 32 avec h<sub>6</sub>-tolerancel<sub>1</sub> = max. Einstecktiefel<sub>1</sub> = max. clamping depthl<sub>1</sub> = max. profondeur d'insertionl<sub>2</sub> = max. Verstellwegl<sub>2</sub> = max. length adjustment rangel<sub>2</sub> = max. course de réglage

Shrink chucks 3° for mounting of solid carbide and HSS-tool shanks - slim

Mandrins de frettage 3° pour le serrage de queues d'outils carbures de type HM et HSS - élancé

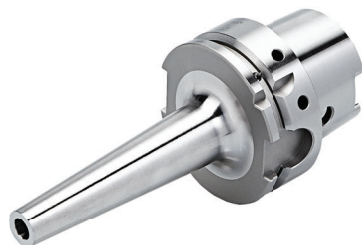

**Verwendung:**  
Zur Aufnahme von Werkzeugen mit Zylinderschaft.

**Application:**  
For mounting straight-shank tools.

**Application:**  
Pour le serrage d'outils avec queue cylindrique.

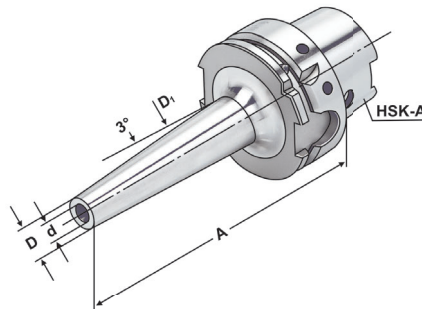

ISO 12164-1  
(DIN 69893-1)

HSK - A

$\lambda \leq 0,003$

G2,5  
25.000 min<sup>-1</sup>

Bestell-Nr. Order no. Référence	HSK	d	A	D	D <sub>1</sub>	l <sub>1</sub>	l <sub>2</sub>
A63.72.03	HSK-A 63	3	80	9	15,5	6	-
A63.72.03.1	HSK-A 63	3	120	9	19,5	6	-
A63.72.04	HSK-A 63	4	80	10	16,5	8	-
A63.72.04.1	HSK-A 63	4	120	10	20,5	8	-
A63.72.05	HSK-A 63	5	80	11	17,5	10	-
A63.72.05.1	HSK-A 63	5	120	11	21,5	10	-
A63.72.06	HSK-A 63	6	80	12	18,5	36	10
A63.72.06.1	HSK-A 63	6	120	12	22,5	36	10
A63.72.06.2	HSK-A 63	6	160	12	26,5	36	10
A63.72.08	HSK-A 63	8	80	14	20,5	36	10
A63.72.08.1	HSK-A 63	8	120	14	24,5	36	10
A63.72.08.2	HSK-A 63	8	160	14	28,5	36	10
A63.72.10	HSK-A 63	10	80	16	22,5	42	10
A63.72.10.1	HSK-A 63	10	120	16	26,5	42	10
A63.72.10.2	HSK-A 63	10	160	16	30,5	42	10
A63.72.12	HSK-A 63	12	80	18	24,5	47	10
A63.72.12.1	HSK-A 63	12	120	18	28,5	47	10
A63.72.12.2	HSK-A 63	12	160	18	32,5	47	10

**Ausführung:** schlanke Bauform (reduzierte Störkontur)  
**Version:** slim design (reduced interference contour)  
**Version:** Modèle très étroit (encombrement réduit)

Für Ø 3, 4 und 5 mm nur Hartmetallschäfte verwenden!

For Ø 3, 4 and 5 mm only solid carbide tool shanks must be used!

Pour Ø 3, 4 et 5 mm il faut seulement utiliser de queues d'outils carbures de type HM!

**Hinweis:** Aufnahmen für Induktiv-, Kontakt- und Heißluftschumpfgeräte geeignet.  
Schafttoleranz bei Ø 3, 4 und 5 mm = h<sub>4</sub>, bei Ø 6 - Ø 32 mm = h<sub>6</sub>

**Note:** Toolholders suitable for induction-, contact- and hot air shrink units.  
Ø 3, 4, 5 with h<sub>4</sub>-tolerance and Ø 6 - Ø 32 with h<sub>6</sub>-tolerance

**Observation:** Porte-outils convenables pour machines à fretter par induction, par contact, ou par air chaud.  
Ø 3, 4, 5 avec h<sub>4</sub>-tolerance et Ø 6 - Ø 32 avec h<sub>6</sub>-tolerance

l<sub>1</sub> = max. Einstecktiefe

l<sub>1</sub> = max. clamping depth

l<sub>1</sub> = max. profondeur d'insertion

l<sub>2</sub> = max. Verstellweg

l<sub>2</sub> = max. length adjustment range

l<sub>2</sub> = max. course de réglage

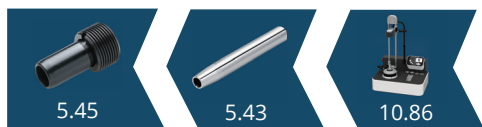



**Verwendung:**  
Zur Aufnahme von Werkzeugen mit Zylinderschaft.

**Application:**  
For mounting straight-shank tools.

**Application:**  
Pour le serrage d'outils avec queue cylindrique.

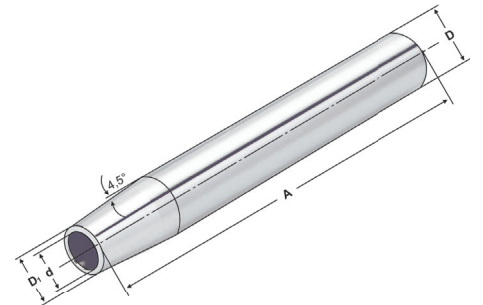

Bestell-Nr. Order no. Référence	D	d	D <sub>1</sub>	A	l <sub>1</sub>	l <sub>2</sub>
120.70.03	20	3	10	150	15	5
120.70.04	20	4	10	150	20	5
120.70.05	20	5	10	150	20	5
120.70.06*	20	6	10	150	36	10
120.70.08*	20	8	12	150	36	10
120.70.10*	20	10	14	150	42	10
120.70.12*	20	12	16	150	47	10

\* mit Anschlag | \* with end stop | \* avec butée

**Für Ø 3, 4 und 5 mm nur Hartmetallschäfte verwenden!**

*For Ø 3, 4 and 5 mm only solid carbide tool shanks must be used!*

*Pour Ø 3, 4 et 5 mm il faut seulement utiliser de queues d'outils carbures de type HM!*

**Hinweis:** Aufnahmen für Induktiv-, Kontakt- und Heißluftschumpfergeräte geeignet.  
Schafttoleranz bei Ø 3, 4 und 5 mm = h<sub>4</sub>, bei Ø 6 – Ø 32 mm = h<sub>6</sub>

**Note:** Toolholders suitable for induction-, contact- and hot air shrink units.  
Ø 3, 4, 5 with h<sub>4</sub>-tolerance and Ø 6 – Ø 32 with h<sub>6</sub>-tolerance

**Observation:** Porte-outils convenables pour machines à fretter par induction, par contact, ou par air chaud.  
Ø 3, 4, 5 avec h<sub>4</sub>-tolerance et Ø 6 – Ø 32 avec h<sub>6</sub>-tolerance

l<sub>1</sub> = max. Einstecktiefe  
l<sub>1</sub> = max. clamping depth  
l<sub>1</sub> = max. profondeur d'insertion

l<sub>2</sub> = max. Verstellweg  
l<sub>2</sub> = max. length adjustment range  
l<sub>2</sub> = max. course de réglage



Test arbors  
Mandrins de contrôle

DIN 69893 (HSK-A)



**Verwendung:**  
Zur Abnahme von Werkzeugmaschinen gemäß ISO-Empfehlung R230 oder zur Überprüfung der Werkzeugspindel.

**Application:**  
For the inspection of machine tools according to ISO recommendation R230 or for testing the tool spindle.

**Application:**  
Pour l'inspection de machine-outils suite à la recommandation ISO R230 ou pour la vérification de la broche.

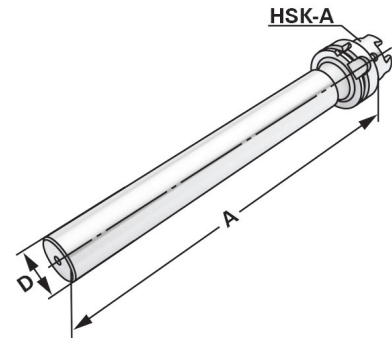

ISO 12164-1  
(DIN 69893-1)      HSK - A       $\nabla \leq 0,003$

Bestell-Nr. Order no. Référence	HSK	D	A	Toleranz Tolerance Tolérance	max. Rundlaufabweichung max. concentricity deviation Faux-rond max.
A32.18.25	HSK-A 32	25	200	0,003	0,003
A40.18.25	HSK-A 40	25	200	0,003	0,003
A50.18.32	HSK-A 50	32	346	0,003	0,003
A63.18.40	HSK-A 63	40	346	0,003	0,003
A80.18.50	HSK-A 80	40	346	0,003	0,003
A100.18.50	HSK-A 100	50	329	0,003	0,003

5

**Lieferumfang:** Auslieferung mit Prüfprotokoll  
**Delivery:** Delivery with test certificate  
**Livraison:** Livraison avec rapport d essais

### Holzkasten für Kontrolldorne

Wooden box for test arbors  
Coffret en bois pour mandrins de contrôle



**Verwendung:**  
Zur Aufbewahrung von Kontrolldornen.

**Application:**  
For the storage of test arbors.

**Application:**  
Pour la conservation de mandrins de contrôle.



Bestell-Nr. Order no. Référence	Abmessung Size Dimension	für Kegelgrößen for cones pour cônes
701.18	460 × 130 × 115	HSK 32 / 40 / 50 / 63 / 80 / 100



**Verwendung:**  
Zur zentralen Übergabe von Kühlmittel bei HSK-Werkzeugaufnahmen.

**Application:**  
*For the coolant supply through the centre of HSK toolholders.*

**Application:**  
Pour l'arrosage centrale de porte-outils HSK.

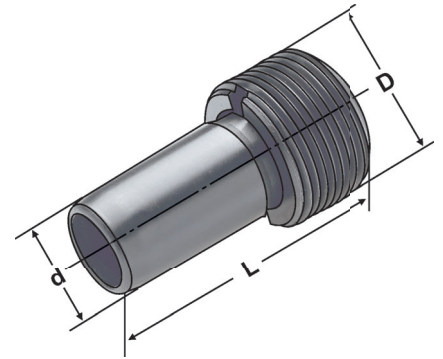

ISO 12164-1  
(DIN 69893-1)

HSK - A

5

Bestell-Nr. Order no. Référence	HSK	D	d	L
A32.700	HSK 32	M10 × 1	6	26,0
A40.700	HSK 40	M12 × 1	8	29,5
A50.700	HSK 50	M16 × 1	10	33,0
A63.700	HSK 63	M18 × 1	12	34,5
A80.700	HSK 80	M20 × 1,5	14	40,0
A100.700	HSK 100	M24 × 1,5	16	44,0

**Hinweis:** Axial abgedichtet mit zwei O-Ringen.  
Die Kühlmittelübergabeeinheit ist nach dem Einbau, gemäß DIN, minimal beweglich ( $\pm 1^\circ$ ).

**Note:** Axial sealed with two O-rings.  
After mounting, the coolant tube can be moved only to a minimum degree according to DIN ( $\pm 1^\circ$ ).

**Observation:** Etanche axiale avec deux joints toriques.  
Après le montage, la canule de lubrification peut être déplacée légèrement suivant DIN ( $\pm 1^\circ$ ).



Key for coolant tubes  
Clés pour canules de lubrification



**Verwendung:**  
Zum Montieren der Kühlmittelübergabeeinheiten in HSK-Werkzeugaufnahmen.

**Application:**  
For mounting the coolant tubes in HSK toolholders.

**Application:**  
Pour le montage de canules de lubrification dans des porte-outils HSK.

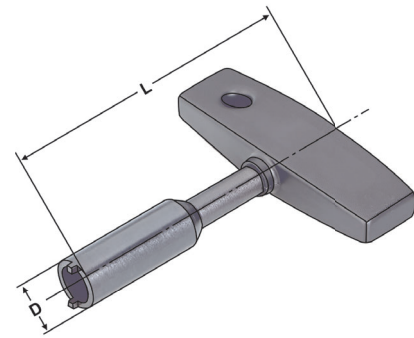

ISO 12164-1  
(DIN 69893-1)

HSK - A

Bestell-Nr. Order no. Référence	HSK	D	L
A32.701	HSK 32	8,5	115
A40.701	HSK 40	10,5	115
A50.701	HSK 50	14,5	115
A63.701	HSK 63	16,5	136
A80.701	HSK 80	18,5	136
A100.701	HSK 100	22,0	136

Vorgewuchtet  
Pre-balanced  
Pré-équilibré

G 6,3 15.000 min<sup>-1</sup>

G 2,5 **Feinwuchten gegen Aufpreis**  
G 2,5 *Fine balancing at extra charge*  
G 2,5 *Équilibrage fin contre un supplément*

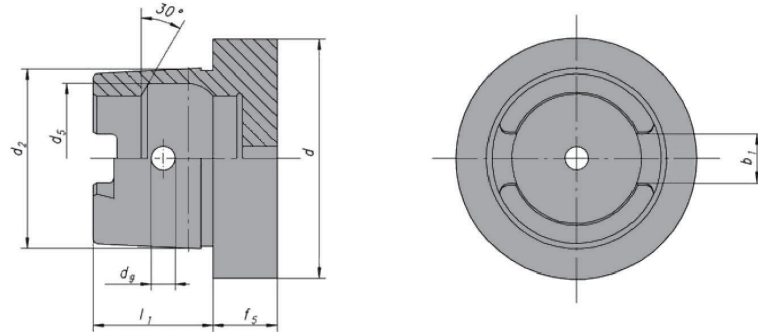

d <sub>1</sub>	l <sub>1</sub>	f <sub>5</sub>	d <sub>2</sub>	d <sub>5</sub>	d <sub>g</sub>	b <sub>1</sub>
32	16	10	24	21	4	7,05
40	20	10	30	25,5	4,6	8,05
50	25	12,5	38	32	6	10,54
63	32	12,5	48	40	7,5	12,54
80	40	16	60	50	8,5	16,04
100	50	16	75	63	12	20,02

5

**Werkstoff:** Legierter Einsatzstahl mit einer Zugfestigkeit im Kern von min. 1200 N / mm<sup>2</sup>. Einsatzgehärtet HRC 60 ± 2 (HV 700 ± 50), Härtetiefe 0,8 mm ± 0,2 mm, brüniert und präzisionsgeschliffen.

**Genauigkeit:** Kegelwinkel – Toleranzqualität < AT 3 nach DIN 7187.

**Material:** *Alloyed case-hardened steel, tensile core strength of min. 1200 N / mm<sup>2</sup>. Case hardened HRC 60 ± 2 (HV 700 ± 50), hardening depth 0.8 mm ± 0.2 mm, black-finished and precisely grinded.*

**Accuracy:** *Quality of taper < AT 3 according to DIN 7187.*

**Matière:** Acier de cémentation allié. Résistance à la traction dans le noyau de min 1200 N / mm<sup>2</sup>. Cémentation à HRC 60 ± 2 (HV 700 ± 50), profondeur de cémentation 0,8 mm ± 0,2 mm, bruni et rectifié précisément.

**Précision:** Qualité du cône < AT 3 suivant DIN 7187.





**Verwendung:**

Zur Aufnahme von Werkzeugen mit Zylinderschaft in Spannzangen.

**Application:**

For mounting straight-shank tools in collets.

**Application:**

Pour le serrage d'outils avec queue cylindrique dans des pinces de serrage.

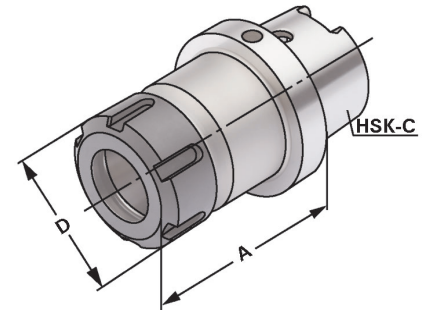
ISO 12164-1  
(DIN 69893-1)

HSK - C

 $\nabla \leq 0,003$ G6,3  
15.000 min<sup>-1</sup>

5

Bestell-Nr. Order no. Référence	HSK	Spannbereich Capacity Capacité	A	D
C25.02.07.M	HSK-C 25	1 – 6 (ER 11) Mini	40	16
C25.02.10.M	HSK-C 25	1 – 10 (ER 16) Mini	55	22
C32.02.10	HSK-C 32	1 – 10 (ER 16)	60	28
C40.02.10.M	HSK-C 40	1 – 10 (ER 16) Mini	70	22
C40.02.10	HSK-C 40	1 – 10 (ER 16)	60	28
C40.02.16	HSK-C 40	2 – 16 (ER 25)	70	42
C40.02.20	HSK-C 40	2 – 20 (ER 32)	75	50
C40.02.26	HSK-C 40	3 – 26 (ER 40)	85	63
C50.02.10	HSK-C 50	1 – 10 (ER 16)	60	28
C50.02.16	HSK-C 50	2 – 16 (ER 25)	70	42
C50.02.20	HSK-C 50	2 – 20 (ER 32)	80	50
C50.02.26	HSK-C 50	3 – 26 (ER 40)	80	63
C50.02.10.1	HSK-C 50	1 – 10 (ER 16)	100	28
C63.02.10	HSK-C 63	1 – 10 (ER 16)	60	28
C63.02.16	HSK-C 63	2 – 16 (ER 25)	70	42
C63.02.20	HSK-C 63	2 – 20 (ER 32)	75	50
C63.02.26	HSK-C 63	3 – 26 (ER 40)	80	63
C63.02.10.1	HSK-C 63	1 – 10 (ER 16)	100	28
C80.02.10	HSK-C 80	1 – 10 (ER 16)	100	28
C80.02.20	HSK-C 80	2 – 20 (ER 32)	80	50
C80.02.26	HSK-C 80	3 – 26 (ER 40)	85	63
C80.02.10.1	HSK-C 80	1 – 10 (ER 16)	160	28
C100.02.10	HSK-C 100	1 – 10 (ER 16)	100	28
C100.02.20	HSK-C 100	2 – 20 (ER 32)	80	50
C100.02.26	HSK-C 100	3 – 26 (ER 40)	90	63
C100.02.10.1	HSK-C 100	1 – 10 (ER 16)	160	28

**Lieferumfang:**Delivery:  
Livraison:Mit gewichteter Spannmutter  
With balanced clamping nut  
Avec écrou de serrage équilibré

End mill holders DIN 6359 for end mills DIN 1835-B

Porte-fraises DIN 6359 pour queues cylindriques DIN 1835-B

DIN 69893 (HSK-C)

**Verwendung:**

Zum Spannen von zylindrischen  
Werkzeugschäften mit seitlicher Spann-  
fläche nach DIN 1835 Form B (Weldon).

**Application:**

For mounting straight-shank tools with flat  
according to DIN 1835 form B (Weldon).

**Application:**

Pour le serrage d'outils avec queue  
cylindrique et avec méplat suivant DIN  
1835 forme B (Weldon).

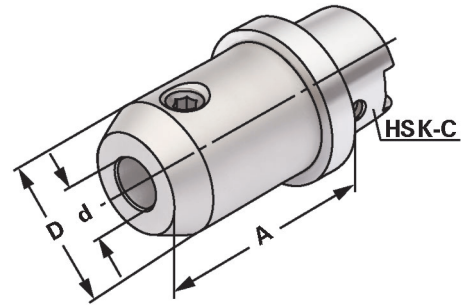
ISO 12164-1  
(DIN 69893-1)

HSK - C

 $\nabla \leq 0,003$ G6,3  
15.000 min<sup>-1</sup>

14.04

Bestell-Nr.  
Order no.  
Référence

HSK

d<sup>H4</sup>

A

D

C40.04.08	HSK-C 40	8	60	28
C40.04.10	HSK-C 40	10	70	35
C40.04.12	HSK-C 40	12	70	42
C40.04.14	HSK-C 40	14	75	44
C40.04.16	HSK-C 40	16	75	48
C40.04.18	HSK-C 40	18	80	50
C40.04.20	HSK-C 40	20	80	52
C50.04.06	HSK-C 50	6	60	25
C50.04.08	HSK-C 50	8	60	28
C50.04.10	HSK-C 50	10	65	35
C50.04.12	HSK-C 50	12	75	42
C50.04.14	HSK-C 50	14	75	44
C50.04.16	HSK-C 50	16	80	48
C50.04.18	HSK-C 50	18	80	50
C50.04.20	HSK-C 50	20	80	50
C50.04.25	HSK-C 50	25	80	50
C63.04.06	HSK-C 63	6	60	25
C63.04.08	HSK-C 63	8	60	28
C63.04.10	HSK-C 63	10	65	35
C63.04.12	HSK-C 63	12	75	42
C63.04.14	HSK-C 63	14	75	44
C63.04.16	HSK-C 63	16	80	48
C63.04.18	HSK-C 63	18	80	50
C63.04.20	HSK-C 63	20	80	52
C63.04.25	HSK-C 63	25	95	65
C63.04.32	HSK-C 63	32	100	72

**Hinweis:****Note:****Observation:**

Ab d = 25 mit zwei Spannschrauben

From d = 25 on two clamping screws

A partir de d = 25 avec deux vis de serrage

**Lieferumfang:****Delivery:****Livraison:**

Mit Spannschraube

With clamping screw

Avec vis de serrage



10.52

**Verwendung:**

Zum Spannen von zylindrischen Werkzeugschäften mit seitlicher Spannfläche nach DIN 1835 Form B (Weldon).

**Application:**

For mounting straight-shank tools with lateral flat according to DIN 1835 form B (Weldon).

**Application:**

Pour le serrage d'outils avec queue cylindrique et avec méplat suivant DIN 1835 forme B (Weldon).

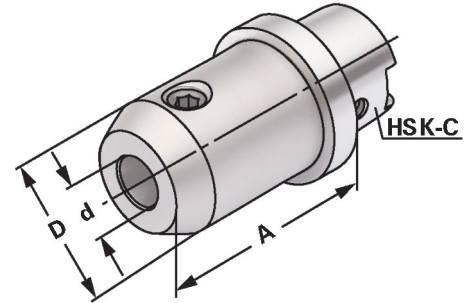
ISO 12164-1  
(DIN 69893-1)

HSK - C

 $\nabla \leq 0,003$ G6,3  
15.000 min<sup>-1</sup>

5

Bestell-Nr. Order no. Référence	HSK	d <sup>H4</sup>	A	D
C100.04.06	HSK-C 100	6	65	25
C100.04.08	HSK-C 100	8	65	28
C100.04.10	HSK-C 100	10	70	35
C100.04.12	HSK-C 100	12	75	42
C100.04.14	HSK-C 100	14	75	44
C100.04.16	HSK-C 100	16	80	48
C100.04.18	HSK-C 100	18	80	50
C100.04.20	HSK-C 100	20	85	52
C100.04.25	HSK-C 100	25	95	65
C100.04.32	HSK-C 100	32	100	72
C100.04.40	HSK-C 100	40	100	80

**Hinweis:** Ab d = 25 mit zwei Spannschrauben  
**Note:** From d = 25 on two clamping screws  
**Observation:** A partir de d = 25 avec deux vis de serrage

**Lieferumfang:** Mit Spannschraube  
**Delivery:** With clamping screw  
**Livraison:** Avec vis de serrage

**Gewuchtete Ausführung****Balanced type  
Type équilibré**

Bestell-Nr. Order no. Référence	Abmessung Size Dimension
<b>Wuchten auf G 2,5 von vorgewuchteten Kemmler-Werkzeugen</b> Balancing at G 2.5 of pre-balanced Kemmler-tools Équilibrage sur G 2,5 d'outils Kemmler pré-équilibrés	
W25	<b>Ohne Wuchtprotokoll</b> Without balancing report Sans protocole d'équilibrage
W25.2	<b>Mit Wuchtprotokoll</b> With balancing report Avec protocole d'équilibrage
<b>Wuchten von nicht vorgewuchteten Werkzeugen</b> Balancing of unbalanced tools Équilibrage d'outils non-équilibrés	
W25.1	<b>Ohne Wuchtprotokoll</b> Without balancing report Sans protocole d'équilibrage





End mill holders DIN 6359 for end mills DIN 1835-E

DIN 69893 (HSK-C)

Porte-fraises DIN 6359 pour queues cylindriques DIN 1835-E

**Verwendung:**

Zum Spannen von zylindrischen Werkzeugschäften mit geneigter Spannfläche nach DIN 1835 Form E (Whistle Notch).

**Application:**

For mounting straight-shank tools and inclined flat according to DIN 1835 form E (Whistle Notch).

**Application:**

Pour le serrage d'outils avec queue cylindrique et avec méplat incliné suivant DIN 1835 forme E (Whistle Notch).

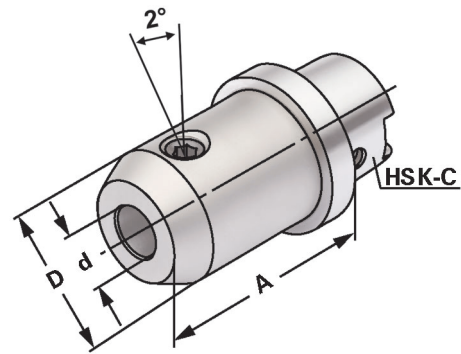
ISO 12164-1  
(DIN 69893-1)

HSK - C

 $\nabla \leq 0,003$ G6,3  
15.000 min<sup>-1</sup>Bestell-Nr.  
Order no.  
Référence

HSK

d<sup>H4</sup>

A

D

C32.05.06	HSK-C 32	6	60	25
C32.05.08	HSK-C 32	8	60	28
C32.05.10	HSK-C 32	10	65	35
C32.05.12	HSK-C 32	12	70	42
C32.05.14	HSK-C 32	14	70	44
C40.05.06	HSK-C 40	6	60	25
C40.05.08	HSK-C 40	8	60	28
C40.05.10	HSK-C 40	10	65	35
C40.05.12	HSK-C 40	12	70	40
C40.05.14	HSK-C 40	14	70	40
C40.05.16	HSK-C 40	16	75	40
C40.05.18	HSK-C 40	18	75	40
C40.05.20	HSK-C 40	20	80	48
C40.05.25	HSK-C 40	25	100	46
C50.05.06	HSK-C 50	6	60	25
C50.05.08	HSK-C 50	8	60	28
C50.05.10	HSK-C 50	10	65	35
C50.05.12	HSK-C 50	12	75	42
C50.05.14	HSK-C 50	14	75	44
C50.05.16	HSK-C 50	16	80	48
C50.05.18	HSK-C 50	18	80	50
C50.05.20	HSK-C 50	20	80	52
C50.05.25	HSK-C 50	25	85	65

**Hinweis:**

Ab d = 25 mit zwei Spannschrauben

**Note:**

From d = 25 on two clamping screws

**Observation:**

A partir de d = 25 avec deux vis de serrage

**Lieferumfang:**

Mit Spannschraube und axialer Verstellechraube

**Delivery:**

With clamping screw and axial adjustment bolt

**Livraison:**

Avec vis de serrage et vis de butée axiale



**Verwendung:**

Zum Spannen von zylindrischen Werkzeugschäften mit geneigter Spannfläche nach DIN 1835 Form E (Whistle Notch).

**Application:**

For mounting straight-shank tools and inclined flat according to DIN 1835 form E (Whistle Notch).

**Application:**

Pour le serrage d'outils avec queue cylindrique et avec méplat incliné suivant DIN 1835 forme E (Whistle Notch).

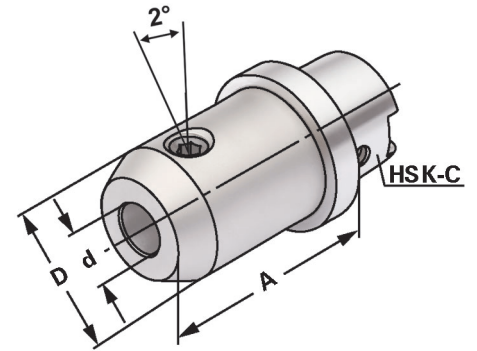
ISO 12164-1  
(DIN 69893-1)

HSK - C

 $\nabla \leq 0,003$ G6.3  
15.000 min<sup>-1</sup>

14.04

5

Bestell-Nr. Order no. Référence	HSK	d <sup>H4</sup>	A	D
C63.05.06	HSK-C 63	6	60	25
C63.05.08	HSK-C 63	8	60	28
C63.05.10	HSK-C 63	10	65	35
C63.05.12	HSK-C 63	12	75	42
C63.05.14	HSK-C 63	14	75	44
C63.05.16	HSK-C 63	16	80	48
C63.05.18	HSK-C 63	18	80	50
C63.05.20	HSK-C 63	20	80	52
C63.05.25	HSK-C 63	25	95	65
C63.05.32	HSK-C 63	32	100	72
C80.05.06	HSK-C 80	6	65	25
C80.05.08	HSK-C 80	8	65	28
C80.05.10	HSK-C 80	10	70	35
C80.05.12	HSK-C 80	12	75	42
C80.05.14	HSK-C 80	14	75	44
C80.05.16	HSK-C 80	16	80	48
C80.05.18	HSK-C 80	18	80	50
C80.05.20	HSK-C 80	20	85	52
C80.05.25	HSK-C 80	25	95	65
C80.05.32	HSK-C 80	32	100	72
C100.05.06	HSK-C 100	6	65	25
C100.05.08	HSK-C 100	8	65	28
C100.05.10	HSK-C 100	10	70	35
C100.05.12	HSK-C 100	12	75	42
C100.05.14	HSK-C 100	14	75	44
C100.05.16	HSK-C 100	16	80	48
C100.05.18	HSK-C 100	18	80	50
C100.05.20	HSK-C 100	20	85	52
C100.05.25	HSK-C 100	25	95	65
C100.05.32	HSK-C 100	32	100	72

**Hinweis:** Ab d = 25 mit zwei Spannschrauben  
**Note:** From d = 25 on two clamping screws  
**Observation:** A partir de d = 25 avec deux vis de serrage

**Lieferumfang:** Mit Spannschraube und axialer Verstellechraube  
**Delivery:** With clamping screw and axial adjustment bolt  
**Livraison:** Avec vis de serrage et vis de butée axiale



Shell mill holders DIN 6357 with enlarged contact face  
 Porte-fraises à trou lisse DIN 6357 avec face de contact élargie

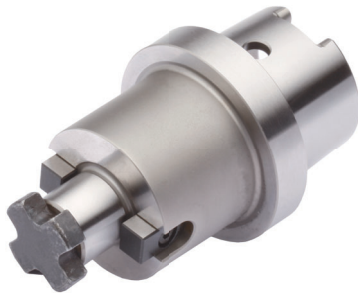

**Verwendung:**  
 Zur Aufnahme von Messerköpfen und Fräsern mit Quernut.  
**Application:**  
 For mounting milling cutters with transversal groove.  
**Application:**  
 Pour le serrage de fraises à rainure transversale.

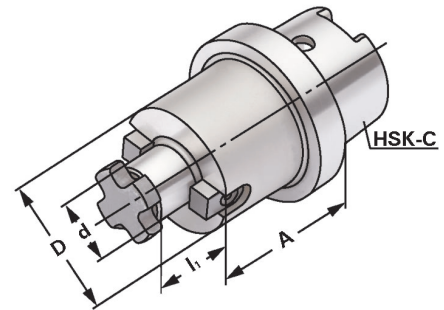

ISO 12164-1 (DIN 69893-1)    HSK - C     $\nabla \leq 0,005$     G6,3 15.000 min<sup>-1</sup>

Bestell-Nr. Order no. Référence	HSK	d <sub>H6</sub>	A	D	l <sub>1</sub>
C40.11.16	HSK-C 40	16	50	40	17
C40.11.22	HSK-C 40	22	60	40	19
C50.11.16	HSK-C 50	16	60	40	17
C50.11.22	HSK-C 50	22	60	50	19
C50.11.27	HSK-C 50	27	60	50	21
C63.11.22	HSK-C 63	22	50	48	19
C63.11.27	HSK-C 63	27	60	60	21
C63.11.32	HSK-C 63	32	60	78	24
C63.11.40	HSK-C 63	40	60	89	27
C80.11.32	HSK-C 80	32	48	78	24
C80.11.40	HSK-C 80	40	60	89	27
C80.11.32.1	HSK-C 80	32	60	78	24
C100.11.22	HSK-C 100	22	50	48	19
C100.11.27	HSK-C 100	27	50	60	21
C100.11.32	HSK-C 100	32	50	78	24
C100.11.40	HSK-C 100	40	60	89	27
C100.11.50	HSK-C 100	50	70	120	30



**d = 40/d = 50:** Für große Planfräser mit vier zusätzlichen Gewindebohrungen nach DIN 2079.  
 For large diameter face mill cutters with four additional threaded holes according to DIN 2079.  
 Pour fraises à surfacer à grands diamètres avec quatre trous taraudés additionnels suivant DIN 2079.

**Lieferumfang:** Mit Mitnehmersteinen und Kreuzschraube.  
**Delivery:** With drivers and cross head retaining screw.  
**Livraison:** Avec tenons et une vis cruciforme.





**Verwendung:**  
Zur Aufnahme von Werkzeugen mit Zylinderschaft.

**Application:**  
For mounting tools with straight shanks.

**Application:**  
Pour le serrage d'outils avec queue cylindrique.

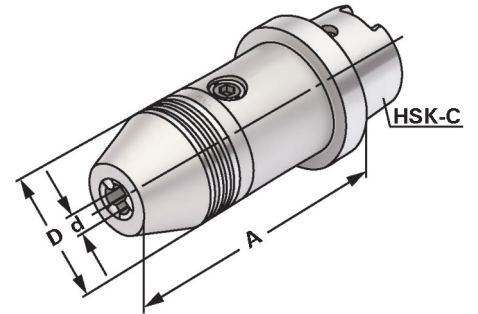

ISO 12164-1  
(DIN 69893-1)

HSK - C

$\nabla \leq 0,030$

G6,3  
15.000 min<sup>-1</sup>

14.04

5

Bestell-Nr. Order no. Référence	HSK	Spannbereich Capacity Capacité	A	D
C50.15.13	HSK-C 50	1,0 – 13	110	50
C50.15.16	HSK-C 50	2,5 – 16	115,5	50
C63.15.13	HSK-C 63	1,0 – 13	110	50
C63.15.16	HSK-C 63	2,5 – 16	115,5	50
C100.15.13	HSK-C 100	1,0 – 13	112,5	50
C100.15.16	HSK-C 100	2,5 – 16	118	50

**Hinweis:** Hohe Präzision und Rundlaufgenauigkeit von  $\leq 0,03$  mm. Sichere Spannung des Werkzeuges durch mechanische Spannkraftverstärkung. Kein selbständiges Lösen der Spannung während der Bearbeitung bei Links- oder Rechtslauf, sowie bei Spindelstop. Spannen und Lösen mit Sechskantschlüssel.

**Note:** *High precision and accurate concentricity of  $\leq 0.03$  mm. Secure gripping of the tool through mechanical amplification of the clamping force. No automatic slackening of the clamping force while machining with either clockwise or counter clockwise rotation or on spindle stop. Clamping and releasing effected by means of an Allen wrench.*

**Observation:** Précision élevée et exactitude de circularité de  $\leq 0,03$  mm. Serrage sûr de l'outil grâce à l'amplification de la force de serrage. Pas de desserrage intempestif en cours d'usinage lors de la rotation la gauche ou la droite, de même qu'en cas d'arrêt de la broche. Serrage et desserrage en utilisant un clé sur à fourche.

**Lieferumfang:** Mit Spannschlüssel  
**Delivery:** With wrench  
**Livraison:** Avec clé de serrage



10.23

Boring bar blanks  
Barres d'alésage



**Verwendung:**  
Zur Herstellung von Sonderwerkzeugen.  
**Application:**  
For the manufacturing of special tools.  
**Application:**  
Pour la fabrication d'outils spéciaux.

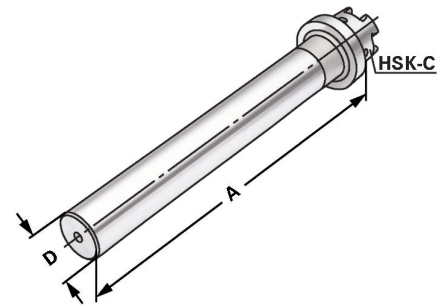

ISO 12164-1  
(DIN 69893-1)

HSK - C

Bestell-Nr. Order no. Référence	HSK	A	D
C25.17.32	HSK-C 25	110	32
C32.17.32	HSK-C 32	160	32
C40.17.50	HSK-C 40	160	43
C50.17.50	HSK-C 50	200	50
C63.17.63	HSK-C 63	250	63
C80.17.80	HSK-C 80	250	80
C100.17.93	HSK-C 100	250	93

5

**Ausführung:** Kegel und Bund gehärtet und geschliffen. Schaft weich zur weiteren Bearbeitung.  
**Version:** Cone and flange hardened and grinded. Soft body for later processing.  
**Version:** Cône et collerette durcis et rectifiés. Corps doux pour un usinage ultérieur.

### Gewuchtete Ausführung

Balanced type  
Type équilibré

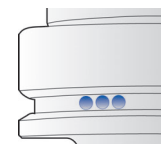

Bestell-Nr. Order no. Référence	Abmessung Size Dimension
---------------------------------------	--------------------------------

Wuchten auf G 2,5 von vorgewuchteten  
Kemmler-Werkzeugen

Balancing at G 2.5 of pre-balanced Kemmler-tools  
Équilibrage sur G 2,5 d'outils Kemmler pré-équilibrés

W25

**Ohne Wuchtprotokoll**

Without balancing report  
Sans protocole d'équilibrage

W25.2

**Mit Wuchtprotokoll**

With balancing report  
Avec protocole d'équilibrage

Wuchten von nicht vorgewuchteten Werkzeugen  
Balancing of unbalanced tools  
Équilibrage d'outils non-équilibrés

W25.1

**Ohne Wuchtprotokoll**

Without balancing report  
Sans protocole d'équilibrage





**Verwendung:**  
Zur Abnahme von Werkzeugmaschinen gemäß ISO-Empfehlung R230 oder zur Überprüfung der Werkzeugspindel.

**Application:**  
For the inspection of machine tools according to ISO recommendation R230 or for testing the tool spindle.

**Application:**  
Pour l'inspection de machine-outils suite à la recommandation ISO R230 ou pour la vérification de la broche.

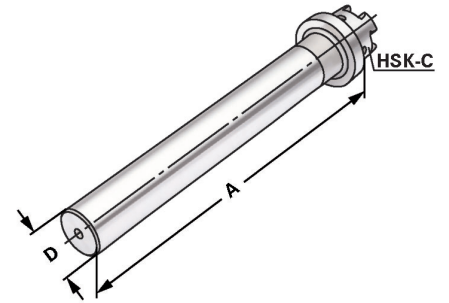

ISO 12164-1  
(DIN 69893-1)

HSK - C

$\nabla \leq 0,003$

5

Bestell-Nr. Order no. Référence	HSK	D	A	Toleranz Tolerance Tolérance	max. Rundlaufabweichung max. concentricity deviation Faux-rond max.
C32.18.25	HSK-C 32	25	160	0,003	0,003
C40.18.25	HSK-C 40	25	160	0,003	0,003
C50.18.32	HSK-C 50	32	300	0,003	0,003
C63.18.40	HSK-C 63	40	300	0,003	0,003
C80.18.40	HSK-C 80	40	300	0,003	0,003
C100.18.50	HSK-C 100	50	300	0,003	0,003

**Lieferumfang:** Auslieferung mit Prüfprotokoll  
**Delivery:** Delivery with test certificate  
**Livraison:** Livraison avec rapport d essais

## Holzkasten für Kontrolldorne

**Wooden box for test arbors**  
**Coffret en bois pour mandrins de contrôle**



**Verwendung:**  
Zur Aufbewahrung von Kontrolldornen.

**Application:**  
For the storage of test arbors.

**Application:**  
Pour la conservation de mandrins de contrôle.



Bestell-Nr.  
Order no.  
Référence

Abmessung  
Size  
Dimension

für Kegelgrößen  
for cones  
pour cônes

701.18

460 × 130 × 115

HSK 32 / 40 / 50 / 63 / 80 / 100



Technische Datenblätter, STEP/STL Modelle für die Simulation der NC-Programme und DXF-Zeichnungen zur Erstellung des Einrichteblattes stehen Online zur Verfügung.

*Technical data sheets, STEP/STL models for the simulation of NC programs and DXF drawings to create the tooling sheet are online available.*

Fiches techniques, STEP/STL modèles techniques pour la simulation de programmes CN et dessins DXF pour créer la feuille d'installation sont disponible online.

Sie können unsere Kataloge entweder direkt im Browser betrachten oder sie auf Ihren PC, Smartphone oder Tablet herunterladen (PDF-Reader notwendig).

*You can view our catalogues either directly in the browser or download to your PC, smartphone or tablet (PDF reader required).*

Vous pouvez consulter nos catalogues directement dans le navigateur ou télécharger sur votre PC, smartphone ou tablet (lecteur PDF requis).

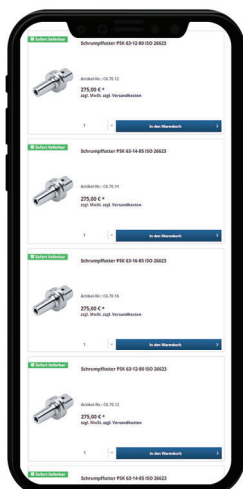

Auf unserer Internetseite können Sie die Lagerverfügbarkeit prüfen - auch auf Mobilgeräten.

*On our website you can check the stock availability - also on mobile devices.*

Vous pouvez également vérifier la disponibilité de nos produits sur le site Internet - ainsi que sur vos appareils



**Verwendung:**  
Zur Aufnahme von Werkzeugen mit Zylinderschaft nach DIN 1835 Form A+B+E und DIN 6535 Form HA+HB+HE

**Application:**  
For mounting straight-shank tools acc. DIN 1835 form A+B+E and DIN 6535 form HA+HB+HE.

**Application:**  
Pour le serrage d'outils avec queue cylindrique suivant DIN 1835 forme A+B+E et DIN 6535 forme HA+HB+HE.

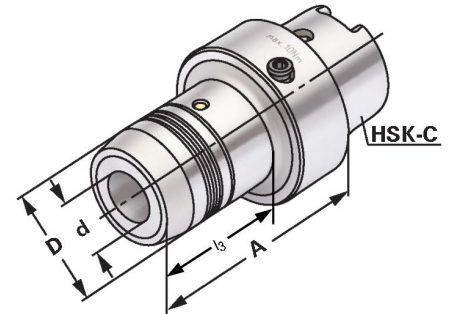

ISO 12164-1  
(DIN 69893-1)

HSK - C

$\nabla \leq 0,003$

G6,3  
15.000 min<sup>-1</sup>

14.04

5

Bestell-Nr. Order no. Référence	HSK	d	A	D	l <sub>1</sub>	l <sub>2</sub>	l <sub>3</sub>
C25.H06	HSK-C 25	6	60	26	37	10	38
C25.H08	HSK-C 25	8	60	28	37	10	38
C25.H10	HSK-C 25	10	65	30	42	10	38
C32.H06	HSK-C 32	6	60	26	37	10	35
C32.H08	HSK-C 32	8	60	28	37	10	36
C32.H10	HSK-C 32	10	65	30	42	10	52
C32.H12	HSK-C 32	12	70	32	47	10	-
C32.H14	HSK-C 32	14	75	34	47	10	65
C32.H08.1	HSK-C 32	8	67	26	37	10	42
C32.H10.1	HSK-C 32	10	72,5	30	42	10	48,5
C32.H12.1	HSK-C 32	12	76	32	47	10	-
C40.H06	HSK-C 40	6	60	26	37	10	35
C40.H08	HSK-C 40	8	60	28	37	10	36
C40.H10	HSK-C 40	10	65	30	42	10	38
C40.H12	HSK-C 40	12	70	32	47	10	47
C40.H14	HSK-C 40	14	80	34	47	10	49
C40.H16	HSK-C 40	16	80	38	52	10	49
C40.H18	HSK-C 40	18	80	40	52	10	49
C40.H20	HSK-C 40	20	80	40	52	10	49
C50.H06	HSK-C 50	6	60	26	37	10	33
C50.H08	HSK-C 50	8	60	28	37	10	33
C50.H10	HSK-C 50	10	65	30	42	10	39
C50.H12	HSK-C 50	12	75	32	47	10	44
C50.H14	HSK-C 50	14	75	34	47	10	46
C50.H16	HSK-C 50	16	80	38	52	10	51
C50.H18	HSK-C 50	18	80	40	52	10	52
C50.H20	HSK-C 50	20	80	42	52	10	58

**Lieferumfang:** Mit Spannschlüssel  
**Delivery:** With wrench  
**Livraison:** Avec clé de serrage

l<sub>1</sub> = max. Einstecktiefe  
l<sub>1</sub> = max. clamping depth  
l<sub>1</sub> = max. profondeur d'insertion

l<sub>2</sub> = max. Verstellweg  
l<sub>2</sub> = max. length adjustment range  
l<sub>2</sub> = max. course de réglage



**Verwendung:**  
Zur Aufnahme von Werkzeugen mit Zylinderschaft nach DIN 1835 Form A+B+E und DIN 6535 Form HA+HB+HE

**Application:**  
For mounting straight-shank tools acc. DIN 1835 form A+B+E and DIN 6535 form HA+HB+HE.

**Application:**  
Pour le serrage d'outils avec queue cylindrique suivant DIN 1835 forme A+B+E et DIN 6535 forme HA+HB+HE.

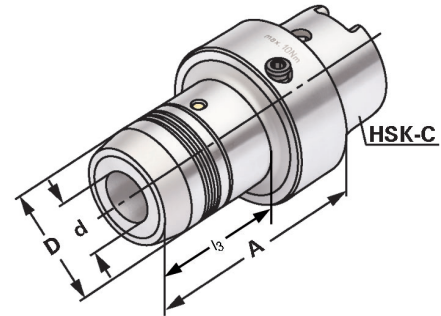

ISO 12164-1 (DIN 69893-1)    HSK - C     $\lambda \leq 0,003$     G6,3 15.000 min<sup>-1</sup>



Bestell-Nr. Order no. Référence	HSK	d	A	D	l <sub>1</sub>	l <sub>2</sub>	l <sub>3</sub>
C63.H06	HSK-C 63	6	60	26	37	10	29
C63.H08	HSK-C 63	8	60	28	37	10	29
C63.H10	HSK-C 63	10	65	30	42	10	35
C63.H12	HSK-C 63	12	75	32	47	10	40
C63.H14	HSK-C 63	14	75	34	47	10	42
C63.H16	HSK-C 63	16	80	38	52	10	47
C63.H18	HSK-C 63	18	80	40	52	10	48
C63.H20	HSK-C 63	20	80	42	52	10	54
C63.H25	HSK-C 63	25	95	50	58	10	51
C63.H32	HSK-C 63	32	100	60	62	10	59



**Lieferumfang:** Mit Spannschlüssel  
**Delivery:** With wrench  
**Livraison:** Avec clé de serrage

l<sub>1</sub> = max. Einstecktiefe    l<sub>2</sub> = max. Verstellweg  
l<sub>1</sub> = max. clamping depth    l<sub>2</sub> = max. length adjustment range  
l<sub>1</sub> = max. profondeur d'insertion    l<sub>2</sub> = max. course de réglage

## Gewuchtete Ausführung

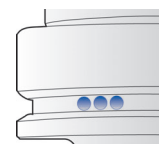

Balanced type  
Type équilibré

Bestell-Nr. Order no. Référence	Abmessung Size Dimension
---------------------------------------	--------------------------------

**Wuchten auf G 2,5 von vorgewuchteten Kemmler-Werkzeugen**  
Balancing at G 2.5 of pre-balanced Kemmler-tools  
Équilibrage sur G 2,5 d'outils Kemmler pré-équilibrés

W25    **Ohne Wuchtprotokoll**  
Without balancing report  
Sans protocole d'équilibrage

W25.2    **Mit Wuchtprotokoll**  
With balancing report  
Avec protocole d'équilibrage

**Wuchten von nicht vorgewuchteten Werkzeugen**  
Balancing of unbalanced tools  
Équilibrage d'outils non-équilibrés

W25.1    **Ohne Wuchtprotokoll**  
Without balancing report  
Sans protocole d'équilibrage





Shrink chucks 4,5° for mounting of solid carbide and HSS-tool shanks

Mandrins de frettage 4,5° pour le serrage de queues d'outils carbures de type HM et HSS

**Verwendung:**

Zur Aufnahme von Werkzeugen mit Zylinderschaft.

**Application:**

For mounting straight-shank tools.

**Application:**

Pour le serrage d'outils avec queue cylindrique.

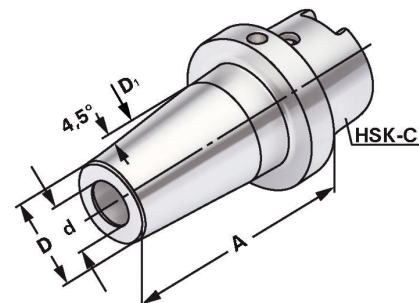
ISO 12164-1  
(DIN 69893-1)

HSK - C

 $\nabla \leq 0,003$ G2.5  
25.000 min<sup>-1</sup>

5

Bestell-Nr. Order no. Référence	HSK	d	A	D	D <sub>1</sub>	l <sub>1</sub>	l <sub>2</sub>
C32.70.06	HSK-C 32	6	65	21	27	36	10
C32.70.08	HSK-C 32	8	65	21	27	36	10
C32.70.10	HSK-C 32	10	65	24	32	42	10
C32.70.12	HSK-C 32	12	75	24	32	47	10
C32.70.14	HSK-C 32	14	80	27	34	47	10
C32.70.16	HSK-C 32	16	80	27	34	50	10
C32.70.06.1	HSK-C 32	6	75	21	27	36	10
C32.70.08.1	HSK-C 32	8	75	21	27	36	10
C32.70.10.1	HSK-C 32	10	80	24	32	42	10
C40.70.03	HSK-C 40	3	70	11	15	10	-
C40.70.04	HSK-C 40	4	70	14	22	20	5
C40.70.05	HSK-C 40	5	70	16	22	20	5
C40.70.06	HSK-C 40	6	70	21	27	36	10
C40.70.08	HSK-C 40	8	70	21	27	36	10
C40.70.10	HSK-C 40	10	70	24	32	42	10
C40.70.12	HSK-C 40	12	80	24	32	47	10
C40.70.14	HSK-C 40	14	80	27	34	47	10
C40.70.16	HSK-C 40	16	80	27	34	50	10
C40.70.18	HSK-C 40	18	80	33	42	50	10
C40.70.20	HSK-C 40	20	80	33	42	52	10
C50.70.06	HSK-C 50	6	70	21	27	36	10
C50.70.08	HSK-C 50	8	70	21	27	36	10
C50.70.10	HSK-C 50	10	75	24	32	42	10
C50.70.12	HSK-C 50	12	75	24	32	47	10
C50.70.14	HSK-C 50	14	80	27	34	47	10
C50.70.16	HSK-C 50	16	85	27	34	50	10
C50.70.18	HSK-C 50	18	85	33	42	50	10
C50.70.20	HSK-C 50	20	90	33	42	52	10

**Hinweis:** Aufnahme für Induktiv-, Kontakt- und Heißluftschumpfergeräte geeignet.  
Schafttoleranz bei Ø 3, 4 und 5 mm = h<sub>4</sub>, bei Ø 6 - Ø 32 mm = h<sub>6</sub>

**Note:** Toolholders suitable for induction-, contact- and hot air shrink units.  
Ø 3, 4, 5 with h<sub>4</sub>-tolerance and Ø 6 - Ø 32 with h<sub>6</sub>-tolerance

**Observation:** Porte-outils convenables pour machines à fretter par induction, par contact, ou par air chaud.  
Ø 3, 4, 5 avec h<sub>4</sub>-tolerance et Ø 6 - Ø 32 avec h<sub>6</sub>-tolerance

l<sub>1</sub> = max. Einstecktiefe  
l<sub>1</sub> = max. clamping depth  
l<sub>1</sub> = max. profondeur d'insertion  
l<sub>2</sub> = max. Verstellweg  
l<sub>2</sub> = max. length adjustment range  
l<sub>2</sub> = max. course de réglage

# Schrumpfutter 4,5° mit Kühlkanälen

## zum Spannen von HM und HSS Werkzeugschäften

ISO 12164 (HSK-C)

DIN 69893 (HSK-C)



*Shrink chucks 4,5° for mounting of solid carbide and HSS-tool shanks*

*Mandrins de frettage 4,5° pour le serrage de queues d'outils carbures de type HM et HSS*



**Verwendung:**  
Zur Aufnahme von Werkzeugen mit Zylinderschaft.

**Application:**  
*For mounting straight-shank tools.*

**Application:**  
Pour le serrage d'outils avec queue cylindrique.

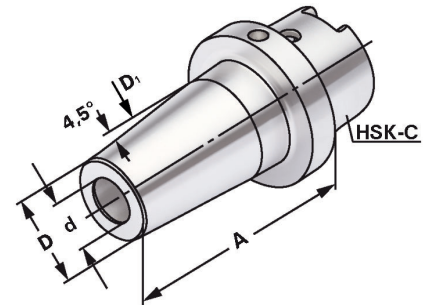

ISO 12164-1  
(DIN 69893-1)

HSK - C

$\nabla \leq 0,003$

G2,5  
25.000 min<sup>-1</sup>

Bestell-Nr. Order no. Référence	HSK	d	A	D	D <sub>1</sub>	l <sub>1</sub>	l <sub>2</sub>
C63.70.06	HSK-C 63	6	70	21	27	36	10
C63.70.08	HSK-C 63	8	70	21	27	36	10
C63.70.10	HSK-C 63	10	75	24	32	42	10
C63.70.12	HSK-C 63	12	80	24	32	47	10
C63.70.14	HSK-C 63	14	80	27	34	47	10
C63.70.16	HSK-C 63	16	85	27	34	50	10
C63.70.18	HSK-C 63	18	85	33	42	50	10
C63.70.20	HSK-C 63	20	90	33	42	52	10
C63.70.25	HSK-C 63	25	100	44	53	58	10
C63.70.32	HSK-C 63	32	110	44	53	61	10

5

**Hinweis:** Aufnahme für Induktiv-, Kontakt- und Heißluftschumpfgeräte geeignet.  
Schafttoleranz bei  $\varnothing 6 - \varnothing 32 \text{ mm} = h_6$

**Note:** *Toolholders suitable for induction-, contact- and hot air shrink units.  
 $\varnothing 6 - \varnothing 32$  with  $h_6$ -tolerance*

**Observation:** Porte-outils convenables pour machines à fretter par induction,  
par contact, ou par air chaud.  
 $\varnothing 6 - \varnothing 32$  avec  $h_6$ -tolerance

l<sub>1</sub> = max. Einstecktiefe      l<sub>2</sub> = max. Verstellweg  
l<sub>1</sub> = max. clamping depth      l<sub>2</sub> = max. length adjustment range  
l<sub>1</sub> = max. profondeur d'insertion      l<sub>2</sub> = max. course de réglage

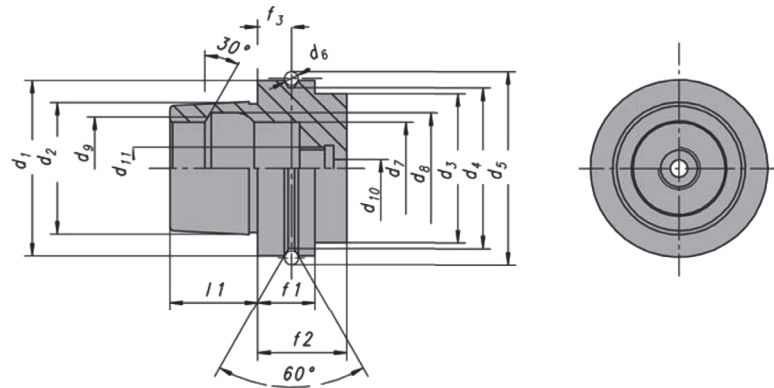

**Toolholders DIN 69893-5 form E**  
**Porte-outils DIN 69893-5 forme E**
**Vorgewuchtet**  
*Pre-balanced*  
*Pré-équilibré*
**G 6,3 15.000 min<sup>-1</sup>**
**G 2,5 Feinwuchten gegen Aufpreis**  
*G 2.5 Fine balancing at extra charge*  
*G 2,5 Equilibrage fin contre un supplément*

d <sub>1</sub>	d <sub>2</sub>	d <sub>3</sub>	d <sub>4</sub>	d <sub>5 -0,1</sub>	d <sub>6 -0,1</sub>	d <sub>8 H10</sub>	d <sub>9 H11</sub>	d <sub>10</sub>	d <sub>11</sub>	f <sub>1 -0,1</sub>	f <sub>2 min.</sub>	f <sub>3 ±0,1</sub>	l <sub>1 -0,2</sub>	l <sub>2 js10</sub>	l <sub>3</sub>
25	19 <sup>+0,006 +0,004</sup>	18,15	20	22	28,5	14	16,4	15	M8x1	10	20	4,5	13	7,21	8,5
32	24 <sup>+0,007 +0,005</sup>	23,27	26	26,5	37	17	21	19	M10x1	20	35	16	16	8,92	7,3
40	30 <sup>+0,007 +0,005</sup>	29,05	34	34,8	45	21	25,5	23	M12x1	20	35	16	20	11,42	9,5
50	38 <sup>+0,009 +0,006</sup>	36,90	42	43	59,3	26	32	29	M16x1	26	42	18	25	14,13	11,0
63	48 <sup>+0,011 +0,007</sup>	46,53	53	55	72,3	34	40	37	M18x1	26	42	18	32	18,13	14,7

**5**
**Werkstoff:** Legierter Einsatzstahl mit einer Zugfestigkeit im Kern von min. 1200 N / mm<sup>2</sup>.  
 Einsatzgehärtet HRC 60 ± 2 (HV 700 ± 50), Härtetiefe 0,8 mm ± 0,2 mm, brüniert und präzisionsgeschliffen.

**Genauigkeit:** Kegelwinkel – Toleranzqualität < AT 3 nach DIN 7187.

**Material:** *Alloyed case-hardened steel, tensile core strength of min. 1200 N / mm<sup>2</sup>.  
 Case hardened HRC 60 ± 2 (HV 700 ± 50), hardening depth 0.8 mm ± 0.2 mm, black-finished and precisely grinded.*
**Accuracy:** *Quality of taper < AT 3 according to DIN 7187.*
**Matière:** Acier de cémentation allié. Résistance à la traction dans le noyau de min 1200 N / mm<sup>2</sup>.  
 Cémentation à HRC 60 ± 2 (HV 700 ± 50), profondeur de cémentation 0,8 mm ± 0,2 mm, bruni et rectifié précisément.

**Précision:** Qualité du cône < AT 3 suivant DIN 7187.



Index  
Sommaire







## DIN 6499 (ISO 15488) System ER

Collet chucks for collets DIN 6499 (ISO 15488) ER-system

Mandrins à pinces pour pinces DIN 6499 (ISO 15488) système ER

**Verwendung:**

Zur Aufnahme von Werkzeugen mit Zylinderschaft in Spannzangen.

**Application:**

For mounting straight-shank tools in collets.

**Application:**

Pour le serrage d'outils avec queue cylindrique dans des pinces de serrage.

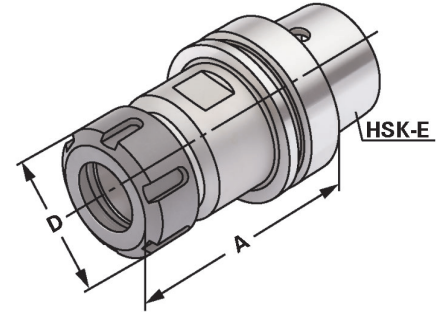
ISO 12164-1  
(DIN 69893-1)

HSK - E

 $\nabla \leq 0,003$ G6,3  
15.000 min<sup>-1</sup>

14.04

5

Bestell-Nr. Order no. Référence	HSK	Spannbereich Capacity Capacité	A	D
E25.02.10.M	HSK-E 25	1 – 10 (ER 16) Mini	52	22
E25.02.10	HSK-E 25	1 – 10 (ER 16)	65	28
E25.02.16.M	HSK-E 25	1 – 16 (ER 25) Mini	70	35
E32.02.07.M	HSK-E 32	1 – 7 (ER 11) Mini	60	16
E32.02.10.M	HSK-E 32	1 – 10 (ER 16) Mini	65	22
E32.02.13.M	HSK-E 32	1 – 13 (ER 20) Mini	75	28
E32.02.16.M	HSK-E 32	1 – 16 (ER 25) Mini	85	35
E32.02.20	HSK-E 32	2 – 20 (ER 32)	95	50
E40.02.10.M	HSK-E 40	1 – 10 (ER 16) Mini	100	22
E40.02.10	HSK-E 40	1 – 10 (ER 16)	65	28
E40.02.16	HSK-E 40	1 – 16 (ER 25)	75	42
E40.02.20	HSK-E 40	2 – 20 (ER 32)	100	50
E50.02.10	HSK-E 50	1 – 10 (ER 16)	80	28
E50.02.16	HSK-E 50	1 – 16 (ER 25)	80	42
E50.02.20	HSK-E 50	2 – 20 (ER 32)	85	50
E50.02.26	HSK-E 50	3 – 26 (ER 40)	100	63
E63.02.10.1	HSK-E 63	1 – 10 (ER 16)	75	28
E63.02.16	HSK-E 63	1 – 16 (ER 25)	80	42
E63.02.20	HSK-E 63	2 – 20 (ER 32)	90	50
E63.02.26	HSK-E 63	3 – 26 (ER 40)	120	63

**Lieferumfang:** Mit gewuchteter Spannmutter  
**Delivery:** With balanced clamping nut  
**Livraison:** Avec écrou de serrage équilibré



End mill holders DIN 6359 for end mills DIN 1835-B  
Porte-fraises DIN 6359 pour queues cylindriques DIN 1835-B



**Verwendung:**  
Zum Spannen von zylindrischen Werkzeugschäften mit seitlicher Spannfläche nach DIN 1835 Form B (Weldon).

**Application:**  
For mounting straight-shank tools with lateral flat according to DIN 1835 form B (Weldon).

**Application:**  
Pour le serrage d'outils avec queue cylindrique et avec méplat suivant DIN 1835 forme B (Weldon).

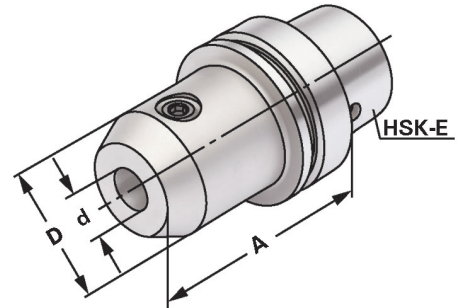

ISO 12164-1  
(DIN 69893-1)

HSK - E

$\nabla \leq 0,003$

G6,3  
15.000 min<sup>-1</sup>

14.04

Bestell-Nr. Order no. Référence	HSK	d <sup>H4</sup>	A	D
E32.04.06	HSK-E 32	6	60	25
E32.04.08	HSK-E 32	8	60	28
E32.04.10	HSK-E 32	10	65	35
E40.04.06	HSK-E 40	6	60	25
E40.04.08	HSK-E 40	8	60	28
E40.04.10	HSK-E 40	10	60	35
E40.04.12	HSK-E 40	12	70	42
E40.04.14	HSK-E 40	14	75	44
E40.04.16	HSK-E 40	16	75	48
E40.04.20	HSK-E 40	20	75	52
E50.04.06	HSK-E 50	6	65	25
E50.04.08	HSK-E 50	8	65	28
E50.04.10	HSK-E 50	10	65	35
E50.04.12	HSK-E 50	12	80	42
E50.04.14	HSK-E 50	14	80	44
E50.04.16	HSK-E 50	16	80	48
E50.04.18	HSK-E 50	18	80	50
E50.04.20	HSK-E 50	20	80	52
E50.04.25	HSK-E 50	25	102	65
E63.04.06	HSK-E 63	6	65	25
E63.04.08	HSK-E 63	8	65	28
E63.04.10	HSK-E 63	10	65	35
E63.04.12	HSK-E 63	12	80	42
E63.04.14	HSK-E 63	14	80	44
E63.04.16	HSK-E 63	16	80	48
E63.04.18	HSK-E 63	18	80	50
E63.04.20	HSK-E 63	20	80	52
E63.04.25	HSK-E 63	25	110	65
E63.04.32	HSK-E 63	32	110	72
E63.04.40	HSK-E 63	40	120	63

**Hinweis:** Ab d = 25 mit zwei Spannschrauben  
**Note:** From d = 25 on two clamping screws  
**Observation:** A partir de d = 25 avec deux vis de serrage

**Lieferumfang:** Mit Spannschraube  
**Delivery:** With clamping screw  
**Livraison:** Avec vis de serrage



End mill holders DIN 6359 for end mills DIN 1835-E  
Porte-fraises DIN 6359 pour queues cylindriques DIN 1835-E



**Verwendung:**  
Zum Spannen von zylindrischen Werkzeugschäften mit geneigter Spannfläche nach DIN 1835 Form E (Whistle Notch).

**Application:**  
For mounting straight-shank tools and inclined flat according to DIN 1835 form E (Whistle Notch).

**Application:**  
Pour le serrage d'outils avec queue cylindrique et avec méplat incliné suivant DIN 1835 forme E (Whistle Notch).

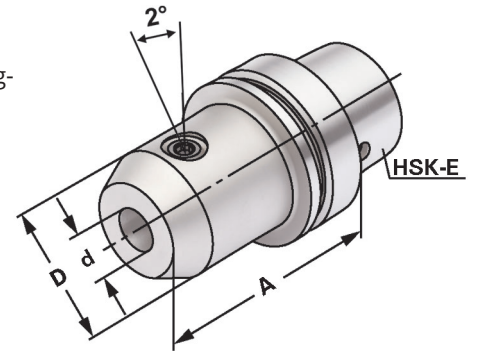

ISO 12164-1  
(DIN 69893-1)

HSK - E

$\nabla \leq 0,003$

G6,3  
15.000 min<sup>-1</sup>



5

Bestell-Nr. Order no. Référence	HSK	d <sup>H4</sup>	A	D
E32.05.06	HSK-E 32	6	60	25
E32.05.08	HSK-E 32	8	80	28
E32.05.10	HSK-E 32	10	80	35
E40.05.06	HSK-E 40	6	60	25
E40.05.08	HSK-E 40	8	80	28
E40.05.10	HSK-E 40	10	80	35
E40.05.12	HSK-E 40	12	90	42
E40.05.14	HSK-E 40	14	90	44
E40.05.16	HSK-E 40	16	90	48
E50.05.06	HSK-E 50	6	80	25
E50.05.08	HSK-E 50	8	80	28
E50.05.10	HSK-E 50	10	80	35
E50.05.12	HSK-E 50	12	90	42
E50.05.14	HSK-E 50	14	90	44
E50.05.16	HSK-E 50	16	90	48
E50.05.18	HSK-E 50	18	90	50
E50.05.20	HSK-E 50	20	100	52
E63.05.06	HSK-E 63	6	80	25
E63.05.08	HSK-E 63	8	80	28
E63.05.10	HSK-E 63	10	80	35
E63.05.12	HSK-E 63	12	90	42
E63.05.14	HSK-E 63	14	90	44
E63.05.16	HSK-E 63	16	100	48
E63.05.18	HSK-E 63	18	100	50
E63.05.20	HSK-E 63	20	100	52
E63.05.25	HSK-E 63	25	110	65
E63.05.32	HSK-E 63	32	110	72

**Hinweis:** Ab d = 25 mit zwei Spannschrauben  
**Note:** From d = 25 on two clamping screws  
**Observation:** A partir de d = 25 avec deux vis de serrage

**Lieferumfang:** Mit Spannschraube und axialer Verstelle schraube  
**Delivery:** With clamping screw and axial adjustment bolt  
**Livraison:** Avec vis de serrage et vis de butée axiale





mit vergrößerter Anlagefläche

Shell mill holders DIN 6357 with enlarged contact face  
 Porte-fraises à trou lisse DIN 6357 avec face de contact élargie



**Verwendung:**  
 Zur Aufnahme von Messerköpfen und Fräsern mit Quernut.  
**Application:**  
 For mounting milling cutters with transversal groove.  
**Application:**  
 Pour le serrage de fraises à rainure transversale.

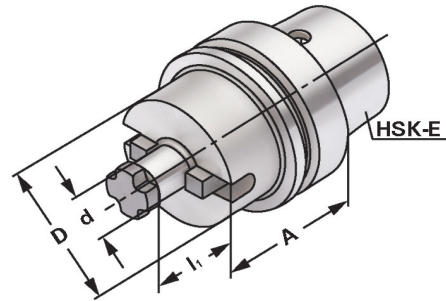

ISO 12164-1 (DIN 69893-1) HSK - E  $\lambda \leq 0,005$  G6,3 15.000 min<sup>-1</sup>

Bestell-Nr. Order no. Référence	HSK	d <sub>h6</sub>	A	l <sub>1</sub>	D
E32.11.16	HSK-E 32	16	50	17	34
E40.11.16	HSK-E 40	16	50	17	34
E40.11.22	HSK-E 40	22	50	19	48
E40.11.27	HSK-E 40	27	55	21	60
E50.11.16	HSK-E 50	16	50	17	38
E50.11.22	HSK-E 50	22	60	19	48
E50.11.27	HSK-E 50	27	60	21	58
E50.11.32	HSK-E 50	32	60	24	65
E63.11.16	HSK-E 63	16	50	17	38
E63.11.22	HSK-E 63	22	60	19	48
E63.11.27	HSK-E 63	27	60	21	58
E63.11.32	HSK-E 63	32	60	24	65
E63.11.40	HSK-E 63	40	60	27	89



**Lieferumfang:** Mit Mitnehmersteinen und Kreuzschraube.  
**Delivery:** With drivers and cross head retaining screw.  
**Livraison:** Avec tenons and une vis cruciforme.

**Gewuchtete Ausführung**

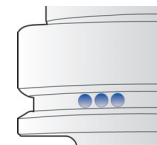

**Balanced type**  
**Type équilibré**

Bestell-Nr. Order no. Référence	Abmessung Size Dimension
---------------------------------------	--------------------------------

- Wuchten auf G 2,5 von vorgewuchteten Kemmler-Werkzeugen**  
*Balancing at G 2.5 of pre-balanced Kemmler-tools*  
 Equilibrage sur G 2,5 d'outils Kemmler pré-équilibrés
- W25 **Ohne Wuchtprotokoll**  
 Without balancing report  
 Sans protocole d'équilibrage
  - W25.2 **Mit Wuchtprotokoll**  
 With balancing report  
 Avec protocole d'équilibrage
- Wuchten von nicht vorgewuchteten Werkzeugen**  
*Balancing of unbalanced tools*  
 Equilibrage d'outils non-équilibrés
- W25.1 **Ohne Wuchtprotokoll**  
 Without balancing report  
 Sans protocole d'équilibrage





CNC-Drill chucks for clockwise and counter clockwise rotation  
Mandrins de perçage CNC pour rotation gauche-droite



**Verwendung:**  
Zur Aufnahme von Werkzeugen mit Zylinderschaft.  
**Application:**  
For mounting tools with straight shanks.  
**Application:**  
Pour le serrage d'outils avec queue cylindrique.

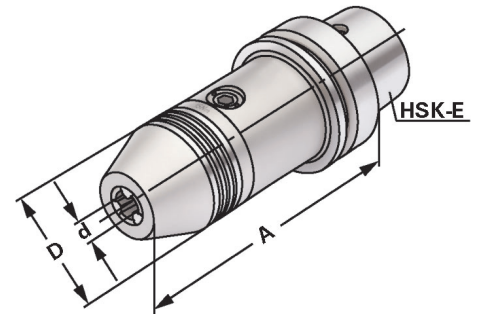

ISO 12164-1  
(DIN 69893-1)

HSK - E

$\nabla \leq 0,030$

G6,3  
15.000 min<sup>-1</sup>



5

Bestell-Nr. Order no. Référence	HSK	Spannbereich Capacity Capacité	A	D
E25.15.08	HSK-E 25	0 – 8	70,0	36
E32.15.08	HSK-E 32	0 – 8	75,0	36
E40.15.08	HSK-E 40	0 – 8	80,0	36
E40.15.13	HSK-E 40	1,0 – 13	119,0	50
E40.15.16	HSK-E 40	2,5 – 16	124,5	50
E50.15.08	HSK-E 50	0 – 8	80	36
E50.15.13	HSK-E 50	1,0 – 13	121,0	50
E50.15.16	HSK-E 50	2,5 – 16	126,5	50
E63.15.13	HSK-E 63	1,0 – 13	123,5	50
E63.15.16	HSK-E 63	2,5 – 16	129,0	50

**Hinweis:** Hohe Präzision und Rundlaufgenauigkeit von  $\leq 0,03$  mm. Sichere Spannung des Werkzeuges durch mechanische Spannkraftverstärkung. Kein selbständiges Lösen der Spannung während der Bearbeitung bei Links- oder Rechtslauf, sowie bei Spindelstop. Spannen und Lösen mit Sechskantschlüssel.

**Note:** High precision and accurate concentricity of  $\leq 0.03$  mm. Secure gripping of the tool through mechanical amplification of the clamping force. No automatic slacking of the clamping force while machining with either clockwise or counter clockwise rotation or on spindle stop. Clamping and releasing effected by means of an Allen wrench.

**Observation:** Précision élevée et exactitude de circularité de  $\leq 0,03$  mm. Serrage sûr de l'outil grâce à l'amplification de la force de serrage. Pas de desserrage intempestif en cours d'usinage lors de la rotation la gauche ou la droite, de même qu'en cas d'arrêt de la broche. Serrage et desserrage en utilisant un clé sur à fourche.

**Lieferumfang:** Mit Spannschlüssel  
**Delivery:** With wrench  
**Livraison:** Avec clé de serrage



10.23

Boring bar blanks  
Barres d'alésage



**Verwendung:**  
Zur Herstellung von Sonderwerkzeugen.  
**Application:**  
*For the manufacturing of special tools.*  
**Application:**  
Pour la fabrication d'outils spéciaux.

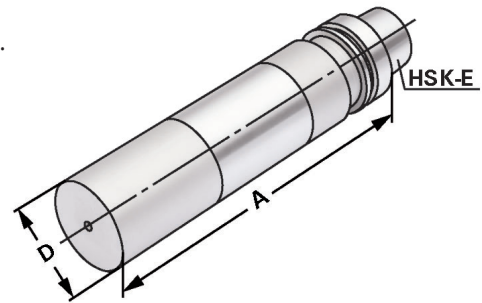

ISO 12164-1  
(DIN 69893-1)

HSK - E

Bestell-Nr. Order no. Référence	HSK	A	D
E25.17.30	HSK-E 25	40	30,0
E32.17.32	HSK-E 32	100	32,5
E40.17.40	HSK-E 40	125	40,5
E50.17.50	HSK-E 50	125	50,5
E63.17.63	HSK-E 63	250	63,5

5

**Ausführung:** Kegel und Bund gehärtet und geschliffen. Schaft weich zur weiteren Bearbeitung.  
**Version:** *Cone and flange hardened and grinded. Soft body for later processing.*  
**Version:** Cône et collerette durcis et rectifiés. Corps doux pour un usinage ultérieur.



*Hydraulic expansion chucks*  
Mandrins expansibles hydrauliques



**Verwendung:**  
Zur Aufnahme von Werkzeugen mit Zylinderschaft nach DIN 1835 Form A+B+E und DIN 6535 Form HA+HB+HE (größer Ø 20 mm nur mit Reduzierung).

**Application:**  
For mounting straight-shank tools acc. DIN 1835 form A+B+E and DIN 6535 form HA+HB+HE (larger than dia. 20 mm only with reduction sleeve).

**Application:**  
Pour le serrage d'outils avec queue cylindrique suivant DIN 1835 forme A+B+E et DIN 6535 forme HA+HB+HE.

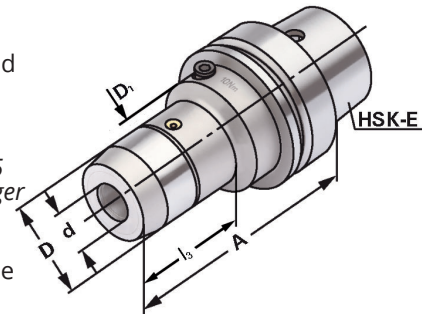

ISO 12164-1  
(DIN 69893-1)

HSK - E

$\nabla \leq 0,003$

G6,3  
15.000 min<sup>-1</sup>

14.04

5

Bestell-Nr. Order no. Référence	HSK	d	A	D	D <sub>1</sub>	l <sub>1</sub>	l <sub>2</sub>	l <sub>3</sub>
E25.H06	HSK-E 25	6	70	26	20	37	10	38
E25.H08	HSK-E 25	8	80	28	20	37	10	-
E25.H10	HSK-E 25	10	85	30	20	42	10	-
E25.H12	HSK-E 25	12	90	32	20	47	10	-
E32.H06	HSK-E 32	6	80	26	26	37	10	60
E32.H08	HSK-E 32	8	80	28	26	37	10	-
E32.H10	HSK-E 32	10	85	30	26	42	10	-
E32.H12	HSK-E 32	12	90	32	26	47	10	-
E40.H06	HSK-E 40	6	80	26	34	37	10	35
E40.H08	HSK-E 40	8	80	28	34	37	10	36
E40.H10	HSK-E 40	10	85	30	34	42	10	41
E40.H12	HSK-E 40	12	90	32	34	47	10	47
E40.H14	HSK-E 40	14	90	34	34	47	10	70
E40.H16	HSK-E 40	16	100	38	34	52	10	-
E40.H20	HSK-E 40	20	100	42	34	52	10	-
E50.H06	HSK-E 50	6	80	26	42	37	10	54
E50.H08	HSK-E 50	8	80	28	42	37	10	54
E50.H10	HSK-E 50	10	85	30	42	42	10	59
E50.H12	HSK-E 50	12	90	32	42	47	10	64
E50.H14	HSK-E 50	14	90	34	42	47	10	64
E50.H16	HSK-E 50	16	95	38	42	52	10	69
E50.H18	HSK-E 50	18	95	40	42	52	10	69
E50.H20	HSK-E 50	20	100	42	42	52	10	74

**Lieferumfang:** Mit Spannschlüssel  
**Delivery:** With wrench  
**Livraison:** Avec clé de serrage

l<sub>1</sub> = max. Einstecktiefe      l<sub>2</sub> = max. Verstellweg  
l<sub>1</sub> = max. clamping depth      l<sub>2</sub> = max. length adjustment range  
l<sub>1</sub> = max. profondeur d'insertion      l<sub>2</sub> = max. course de réglage





Hydraulic expansion chucks  
Mandrins expansibles hydrauliques



**Verwendung:**  
Zur Aufnahme von Werkzeugen mit Zylinderschaft nach DIN 1835 Form A+B+E und DIN 6535 Form HA+HB+HE (größer Ø 20 mm nur mit Reduzierung).

**Application:**  
For mounting straight-shank tools acc. DIN 1835 form A+B+E and DIN 6535 form HA+HB+HE (larger than dia. 20 mm only with reduction sleeve).

**Application:**  
Pour le serrage d'outils avec queue cylindrique suivant DIN 1835 forme A+B+E et DIN 6535 forme HA+HB+HE.

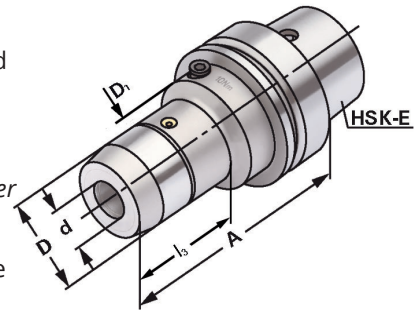

ISO 12164-1 (DIN 69893-1)    HSK - E     $\nabla \leq 0,003$     G6,3 15.000 min<sup>-1</sup>



Bestell-Nr. Order no. Référence	HSK	d	A	D	D <sub>1</sub>	l <sub>1</sub>	l <sub>2</sub>	l <sub>3</sub>
E63.H06	HSK-E 63	6	80	26	50	37	10	33
E63.H08	HSK-E 63	8	80	28	50	37	10	33,5
E63.H10	HSK-E 63	10	85	30	50	42	10	39
E63.H12	HSK-E 63	12	90	32	50	47	10	44,5
E63.H14	HSK-E 63	14	90	34	50	47	10	46
E63.H16	HSK-E 63	16	95	38	50	52	10	51,5
E63.H18	HSK-E 63	18	95	40	50	52	10	52
E63.H20	HSK-E 63	20	100	42	50	52	10	58
E63.H25	HSK-E 63	25	120	50	50	58	10	59
E63.H32	HSK-E 63	32	125	60	60	62	10	59

**Lieferumfang:** Mit Spannschlüssel  
**Delivery:** With wrench  
**Livraison:** Avec clé de serrage

l<sub>1</sub> = max. Einstecktiefe    l<sub>2</sub> = max. Verstellweg  
l<sub>1</sub> = max. clamping depth    l<sub>2</sub> = max. length adjustment range  
l<sub>1</sub> = max. profondeur d'insertion    l<sub>2</sub> = max. course de réglage







## zum Spannen von HM und HSS Werkzeugschäften

*Shrink chucks 4,5° for mounting of solid carbide and HSS-tool shanks*

Mandrins de frettage 4,5° pour le serrage de queues d'outils carbures de type HM et HSS

**Verwendung:**

Zur Aufnahme von Werkzeugen mit Zylinderschaft.

**Application:**

For mounting straight-shank tools.

**Application:**

Pour le serrage d'outils avec queue cylindrique.

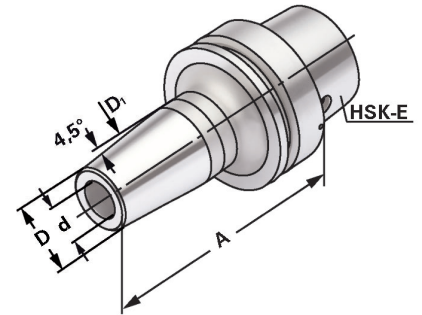
ISO 12164-1  
(DIN 69893-1)

HSK - E

 $\nabla \leq 0,003$ G2,5  
25.000 min<sup>-1</sup>

5

Bestell-Nr. Order no. Référence	HSK	d	A	D	D <sub>1</sub>	l <sub>1</sub>	l <sub>2</sub>
E25.70.03	HSK-E 25	3	40	11	15	10	-
E25.70.04	HSK-E 25	4	40	16	22	20	-
E25.70.05	HSK-E 25	5	50	16	22	20	-
E25.70.06	HSK-E 25	6	50	21	26	36	-
E25.70.08	HSK-E 25	8	50	21	26	36	-
E25.70.10	HSK-E 25	10	50	21	26	42	-
E25.70.12	HSK-E 25	12	50	24	26	47	-
E32.70.03	HSK-E 32	3	70	11	15	10	-
E32.70.04	HSK-E 32	4	70	16	22	20	5
E32.70.05	HSK-E 32	5	70	16	22	20	5
E32.70.06	HSK-E 32	6	70	21	26	36	10
E32.70.08	HSK-E 32	8	70	21	26	36	10
E32.70.10	HSK-E 32	10	70	24	26	42	10
E32.70.12	HSK-E 32	12	80	24	26	47	10
E32.70.04.1	HSK-E 32	4	160	14	21	10	5
E32.70.05.1	HSK-E 32	5	160	16	24	20	5
E32.70.06.1	HSK-E 32	6	160	21	27	36	5
E32.70.08.1	HSK-E 32	8	160	21	27	36	10
E32.70.10.1	HSK-E 32	10	160	24	32	41	10
E32.70.12.1	HSK-E 32	12	160	24	32	47	10
E40.70.03	HSK-E 40	3	75	11	15	10	-
E40.70.04	HSK-E 40	4	80	16	22	20	5
E40.70.05	HSK-E 40	5	80	16	22	20	5
E40.70.06	HSK-E 40	6	80	21	27	36	10
E40.70.08	HSK-E 40	8	80	21	27	36	10
E40.70.10	HSK-E 40	10	80	24	32	42	10
E40.70.12	HSK-E 40	12	90	24	32	47	10
E40.70.14	HSK-E 40	14	90	27	34	47	10
E40.70.16	HSK-E 40	16	90	27	34	50	10

**Hinweis:** Aufnahme für Induktiv-, Kontakt- und Heißluftschumpfgeräte geeignet. Schafttoleranz bei Ø 3, 4 und 5 mm = h<sub>4</sub>, bei Ø 6 – Ø 32 mm = h<sub>6</sub>**Note:** Toolholders suitable for induction-, contact- and hot air shrink units. Ø 3, 4, 5 with h<sub>4</sub>-tolerance and Ø 6 – Ø 32 with h<sub>6</sub>-tolerance**Observation:** Porte-outils convenables pour machines à fretter par induction, par contact, ou par air chaud. Ø 3, 4, 5 avec h<sub>4</sub>-tolerance et Ø 6 – Ø 32 avec h<sub>6</sub>-tolerance

l<sub>1</sub> = max. Einstecktiefe  
 l<sub>1</sub> = max. clamping depth  
 l<sub>1</sub> = max. profondeur d'insertion  
 l<sub>2</sub> = max. Verstellweg  
 l<sub>2</sub> = max. length adjustment range  
 l<sub>2</sub> = max. course de réglage

## zum Spannen von HM und HSS Werkzeugschäften

Shrink chucks 4,5° for mounting of solid carbide and HSS-tool shanks

Mandrins de frettage 4,5° pour le serrage de queues d'outils carbures de type HM et HSS



**Verwendung:**  
Zur Aufnahme von Werkzeugen mit Zylinderschaft.

**Application:**  
For mounting straight-shank tools.

**Application:**  
Pour le serrage d'outils avec queue cylindrique.

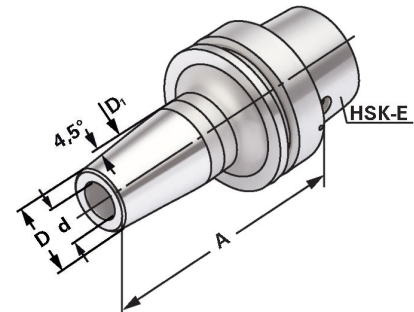
ISO 12164-1  
(DIN 69893-1)

HSK - E

 $\lambda \leq 0,003$ G2,5  
25.000 min<sup>-1</sup>

Bestell-Nr. Order no. Référence	HSK	d	A	D	D <sub>1</sub>	l <sub>1</sub>	l <sub>2</sub>
E40.70.06.1	HSK-E 40	6	130	21	27	36	10
E40.70.08.1	HSK-E 40	8	130	21	27	36	10
E40.70.10.1	HSK-E 40	10	130	24	32	41	10
E40.70.12.1	HSK-E 40	12	130	24	32	47	10
E40.70.14.1	HSK-E 40	14	130	27	34	47	10
E40.70.16.1	HSK-E 40	16	130	27	34	50	10
E50.70.03	HSK-E 50	3	80	11	15	10	-
E50.70.04	HSK-E 50	4	80	16	22	20	5
E50.70.05	HSK-E 50	5	80	16	22	20	5
E50.70.06	HSK-E 50	6	80	21	27	36	10
E50.70.08	HSK-E 50	8	80	21	27	36	10
E50.70.10	HSK-E 50	10	85	24	32	42	10
E50.70.12	HSK-E 50	12	90	24	32	47	10
E50.70.14	HSK-E 50	14	90	27	34	47	10
E50.70.16	HSK-E 50	16	95	27	34	50	10
E50.70.18	HSK-E 50	18	95	33	42	50	10
E50.70.20	HSK-E 50	20	100	33	42	52	10
E50.70.03.1	HSK-E 50	3	120	11	21	10	-
E50.70.04.1	HSK-E 50	4	120	14	21	10	5
E50.70.05.1	HSK-E 50	5	120	16	24	20	5
E50.70.06.1	HSK-E 50	6	120	21	27	36	10
E50.70.08.1	HSK-E 50	8	120	21	27	36	10
E50.70.10.1	HSK-E 50	10	120	24	32	42	10
E50.70.12.1	HSK-E 50	12	120	24	32	47	10
E50.70.14.1	HSK-E 50	14	120	27	34	47	10
E50.70.16.1	HSK-E 50	16	120	27	34	50	10
E50.70.18.1	HSK-E 50	18	120	33	42	50	10
E50.70.20.1	HSK-E 50	20	120	33	42	52	10

Für Ø 3, 4 und 5 mm nur Hartmetallschäfte verwenden!

For Ø 3, 4 and 5 mm only solid carbide tool shanks must be used!

Pour Ø 3, 4 et 5 mm il faut seulement utiliser de queues d'outils carbures de type HM!

**Hinweis:** Aufnahme für Induktiv-, Kontakt- und Heißluftschumpfgeräte geeignet.  
Schafttoleranz bei Ø 3, 4 und 5 mm = h<sub>4</sub>, bei Ø 6 - Ø 32 mm = h<sub>6</sub>

**Note:** Toolholders suitable for induction-, contact- and hot air shrink units.  
Ø 3, 4, 5 with h<sub>4</sub>-tolerance and Ø 6 - Ø 32 with h<sub>6</sub>-tolerance

**Observation:** Porte-outils convenables pour machines à fretter par induction, par contact, ou par air chaud.  
Ø 3, 4, 5 avec h<sub>4</sub>-tolerance et Ø 6 - Ø 32 avec h<sub>6</sub>-tolerance

l<sub>1</sub> = max. Einstecktiefe  
l<sub>1</sub> = max. clamping depth  
l<sub>1</sub> = max. profondeur d'insertion  
l<sub>2</sub> = max. Verstellweg  
l<sub>2</sub> = max. length adjustment range  
l<sub>2</sub> = max. course de réglage



## zum Spannen von HM und HSS Werkzeugschäften

*Shrink chucks 4,5° for mounting of solid carbide and HSS-tool shanks*

Mandrins de frettage 4,5° pour le serrage de queues d'outils carbures de type HM et HSS

**Verwendung:**

Zur Aufnahme von Werkzeugen mit Zylinderschaft.

**Application:**

For mounting straight-shank tools.

**Application:**

Pour le serrage d'outils avec queue cylindrique.

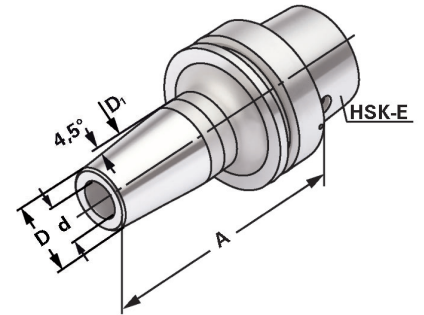
ISO 12164-1  
(DIN 69893-1)

HSK - E

 $\nabla \leq 0,003$ G2,5  
25.000 min<sup>-1</sup>

5

Bestell-Nr. Order no. Référence	HSK	d	A	D	D <sub>1</sub>	l <sub>1</sub>	l <sub>2</sub>
E50.70.03.2	HSK-E 50	3	160	11	21	10	-
E50.70.04.2	HSK-E 50	4	160	14	21	10	5
E50.70.05.2	HSK-E 50	5	160	16	24	20	5
E50.70.06.2	HSK-E 50	6	160	21	27	36	10
E50.70.08.2	HSK-E 50	8	160	21	27	36	10
E50.70.10.2	HSK-E 50	10	160	24	32	41	10
E50.70.12.2	HSK-E 50	12	160	24	32	47	10
E50.70.14.2	HSK-E 50	14	160	27	34	47	10
E50.70.16.2	HSK-E 50	16	160	27	34	50	10
E50.70.18.2	HSK-E 50	18	160	33	42	50	10
E50.70.20.2	HSK-E 50	20	160	33	42	52	10
E63.70.03	HSK-E 63	3	80	11	15	10	-
E63.70.04	HSK-E 63	4	80	14	22	20	5
E63.70.05	HSK-E 63	5	80	16	22	20	5
E63.70.06	HSK-E 63	6	80	21	27	36	10
E63.70.08	HSK-E 63	8	80	21	27	36	10
E63.70.10	HSK-E 63	10	85	24	32	41	10
E63.70.12	HSK-E 63	12	90	24	32	47	10
E63.70.14	HSK-E 63	14	90	27	34	47	10
E63.70.16	HSK-E 63	16	95	27	34	50	10
E63.70.18	HSK-E 63	18	95	33	42	50	10
E63.70.20	HSK-E 63	20	100	33	42	52	10
E63.70.25	HSK-E 63	25	115	44	53	58	10
E63.70.32	HSK-E 63	32	120	44	53	62	10

**Für Ø 3, 4 und 5 mm nur Hartmetallschäfte verwenden!***For Ø 3, 4 and 5 mm only solid carbide tool shanks must be used!*

Pour Ø 3, 4 et 5 mm il faut seulement utiliser de queues d'outils carbures de type HM!

**Hinweis:** Aufnahme für Induktiv-, Kontakt- und Heißluftschumpfergeräte geeignet. Schafttoleranz bei Ø 3, 4 und 5 mm = h<sub>4</sub>, bei Ø 6 - Ø 32 mm = h<sub>6</sub>**Note:** Toolholders suitable for induction-, contact- and hot air shrink units. Ø 3, 4, 5 with h<sub>4</sub>-tolerance and Ø 6 - Ø 32 with h<sub>6</sub>-tolerance**Observation:** Porte-outils convenables pour machines à fretter par induction, par contact, ou par air chaud. Ø 3, 4, 5 avec h<sub>4</sub>-tolerance et Ø 6 - Ø 32 avec h<sub>6</sub>-tolerance

l<sub>1</sub> = max. Einstecktiefe      l<sub>2</sub> = max. Verstellweg  
 l<sub>1</sub> = max. clamping depth      l<sub>2</sub> = max. length adjustment range  
 l<sub>1</sub> = max. profondeur d'insertion      l<sub>2</sub> = max. course de réglage



## zum Spannen von HM und HSS Werkzeugschäften

Shrink chucks 4,5° for mounting of solid carbide and HSS-tool shanks

Mandrins de frettage 4,5° pour le serrage de queues d'outils carbures de type HM et HSS



**Verwendung:**  
Zur Aufnahme von Werkzeugen mit  
Zylinderschaft.

**Application:**  
For mounting straight-shank tools.

**Application:**  
Pour le serrage d'outils avec queue  
cylindrique.

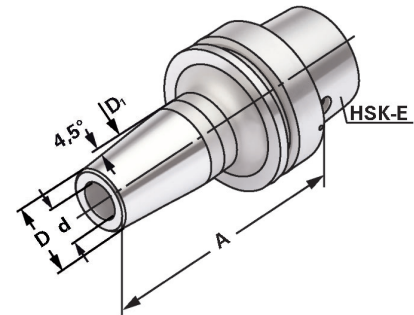
ISO 12164-1  
(DIN 69893-1)

HSK - E

 $\nabla \leq 0,003$ G2,5  
25.000 min<sup>-1</sup>

Bestell-Nr. Order no. Référence	HSK	d	A	D	D <sub>1</sub>	l <sub>1</sub>	l <sub>2</sub>
E63.70.04.1	HSK-E 63	4	120	14	21	10	5
E63.70.06.1	HSK-E 63	6	120	21	27	36	10
E63.70.08.1	HSK-E 63	8	120	21	27	36	10
E63.70.10.1	HSK-E 63	10	120	24	32	41	10
E63.70.12.1	HSK-E 63	12	120	24	32	47	10
E63.70.16.1	HSK-E 63	16	120	27	34	50	10
E63.70.03.2	HSK-E 63	3	160	11	21	10	-
E63.70.04.2	HSK-E 63	4	160	14	21	10	5
E63.70.05.2	HSK-E 63	5	160	16	24	20	5
E63.70.06.2	HSK-E 63	6	160	21	27	36	10
E63.70.08.2	HSK-E 63	8	160	21	27	36	10
E63.70.10.2	HSK-E 63	10	160	24	32	41	10
E63.70.12.2	HSK-E 63	12	160	24	32	47	10
E63.70.14.2	HSK-E 63	14	160	27	34	47	10
E63.70.16.2	HSK-E 63	16	160	27	34	50	10
E63.70.18.2	HSK-E 63	18	160	33	42	50	10
E63.70.20.2	HSK-E 63	20	160	33	42	52	10
E63.70.25.2	HSK-E 63	25	160	44	42	58	10

Für Ø 3, 4 und 5 mm nur Hartmetallschäfte verwenden!

For Ø 3, 4 and 5 mm only solid carbide tool shanks must be used!

Pour Ø 3, 4 et 5 mm il faut seulement utiliser de queues d'outils carbures de type HM!

**Hinweis:** Aufnahme für Induktiv-, Kontakt- und Heißluftschumpfergeräte geeignet.  
Schafttoleranz bei Ø 3, 4 und 5 mm = h<sub>4</sub>, bei Ø 6 – Ø 32 mm = h<sub>6</sub>

**Note:** Toolholders suitable for induction-, contact- and hot air shrink units.  
Ø 3, 4, 5 with h<sub>4</sub>-tolerance and Ø 6 – Ø 32 with h<sub>6</sub>-tolerance

**Observation:** Porte-outils convenables pour machines à fretter par induction,  
par contact, ou par air chaud.  
Ø 3, 4, 5 avec h<sub>4</sub>-tolerance et Ø 6 – Ø 32 avec h<sub>6</sub>-tolerance

l<sub>1</sub> = max. Einstecktiefe      l<sub>2</sub> = max. Verstellweg  
l<sub>1</sub> = max. clamping depth      l<sub>2</sub> = max. length adjustment range  
l<sub>1</sub> = max. profondeur d'insertion      l<sub>2</sub> = max. course de réglage

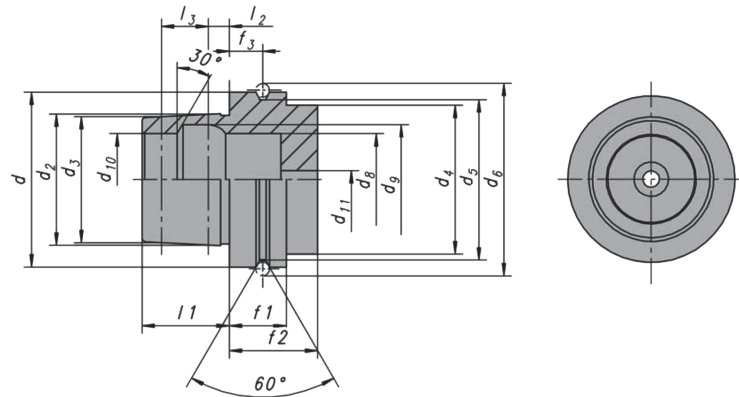

**Toolholders DIN 69893-6 form F**  
**Porte-outils DIN 69893-6 forme F**
**Vorgewuchtet**  
*Pre-balanced*  
*Pré-équilibré*
**G 6,3 15.000 min<sup>-1</sup>**
**G 2,5 Feinwuchten gegen Aufpreis**  
*G 2.5 Fine balancing at extra charge*  
*G 2,5 Equilibrage fin contre un supplément*

d <sub>1</sub>	d <sub>2</sub>	d <sub>3</sub>	d <sub>4</sub>	d <sub>5 -0,1</sub>	d <sub>6 -0,1</sub>	d <sub>8 H10</sub>	d <sub>9 H11</sub>	d <sub>10</sub>	f <sub>1 -0,1</sub>	f <sub>2 min.</sub>	f <sub>3 ±0,1</sub>	l <sub>1 -0,2</sub>	l <sub>2</sub>	l <sub>3</sub>	
50	30	<sup>+0,007</sup> / <sub>+0,005</sub>	29,05 <sup>+0,005</sup> / <sub>+0,003</sub>	42	43	59,3	21	25,5	23	26	42	18	20	4	9,5
63	38	<sup>+0,009</sup> / <sub>+0,006</sub>	36,90 <sup>+0,006</sup> / <sub>+0,003</sub>	53	55	72,3	26	32	29	26	42	18	25	5	11

**5**
**Werkstoff:** Legierter Einsatzstahl mit einer Zugfestigkeit im Kern von min. 1200 N / mm<sup>2</sup>. Einsatzgehärtet HRC 60 ± 2 (HV 700 ± 50), Härtetiefe 0,8 mm ± 0,2 mm, brüniert und präzisionsgeschliffen.

**Genauigkeit:** Kegelwinkel – Toleranzqualität < AT 3 nach DIN 7187.

**Material:** *Alloyed case-hardened steel, tensile core strength of min. 1200 N / mm<sup>2</sup>. Case hardened HRC 60 ± 2 (HV 700 ± 50), hardening depth 0.8 mm ± 0.2 mm, black-finished and precisely grinded.*
**Accuracy:** *Quality of taper < AT 3 according to DIN 7187.*
**Matière:** Acier de cémentation allié. Résistance à la traction dans le noyau de min 1200 N / mm<sup>2</sup>. Cémentation à HRC 60 ± 2 (HV 700 ± 50), profondeur de cémentation 0,8 mm ± 0,2 mm, bruni et rectifié précisément.

**Précision:** Qualité du cône < AT 3 suivant DIN 7187.



Index  
Table de matières

5.79	5.80	5.81	5.83
5.84	5.85	5.86	5.87
5.88	5.89	5.91	



DIN 6388 (ISO 10897) System OZ

Collet chucks for collets DIN 6388 (ISO 10897) OZ-system  
Mandrins à pinces pour pinces DIN 6388 (ISO 10897) système OZ



**Verwendung:**  
Zur Aufnahme von Werkzeugen mit Zylinderschaft in Spannzangen.  
**Application:**  
For mounting straight-shank tools in collets.  
**Application:**  
Pour le serrage d'outils avec queue cylindrique dans des pinces de serrage.

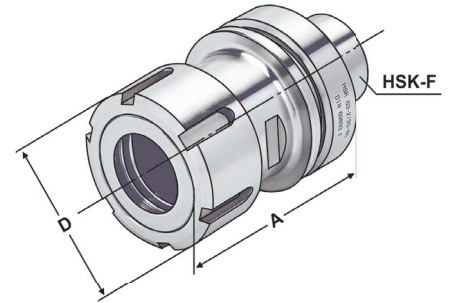

ISO 12164 (DIN 69893)	HSK - F	$\nabla \leq 0,003$	G2,5 25.000 min <sup>-1</sup>	1.4.04
--------------------------	---------	---------------------	----------------------------------	--------

Bestell-Nr. Order no. Référence	HSK	Spannbereich Capacity d Capacité	A	D
F63.01.25	HSK-F 63	2 – 25 (OZ 25)	85	60

5

**Lieferumfang:** Mit gewuchteter Spannmutter  
**Delivery:** With balanced clamping nut  
**Livraison:** Avec écrou de serrage équilibré

Gewuchtete Ausführung

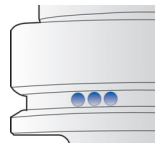

Balanced type  
Type équilibré

Bestell-Nr. Order no. Référence	Abmessung Size Dimension
---------------------------------------	--------------------------------

Wuchten auf G 2,5 von vorgewuchteten  
Kemmler-Werkzeugen  
Balancing at G 2.5 of pre-balanced Kemmler-tools  
Equilibrage sur G 2,5 d'outils Kemmler pré-équilibrés

W25 **Ohne Wuchtprotokoll**  
Without balancing report  
Sans protocole d'équilibrage

W25.2 **Mit Wuchtprotokoll**  
With balancing report  
Avec protocole d'équilibrage

Wuchten von nicht vorgewuchteten Werkzeugen  
Balancing of unbalanced tools  
Equilibrage d'outils non-équilibrés

W25.1 **Ohne Wuchtprotokoll**  
Without balancing report  
Sans protocole d'équilibrage



## DIN 6499 (ISO 15488) System ER

Collet chucks for collets DIN 6499 (ISO 15488) ER-system

Mandrins à pinces pour pinces DIN 6499 (ISO 15488) système ER

**Verwendung:**

Zur Aufnahme von Werkzeugen mit Zylinderschaft in Spannzangen.

**Application:**

For mounting straight-shank tools in collets.

**Application:**

Pour le serrage d'outils avec queue cylindrique dans des pinces de serrage.

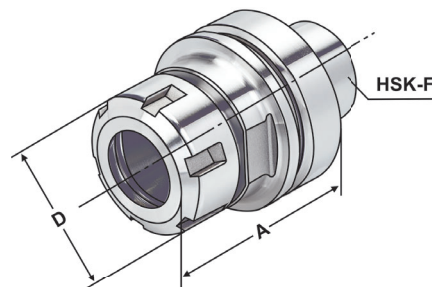
ISO 12164  
(DIN 69893)

HSK - F

 $\nabla \leq 0,003$ G2,5  
25.000 min<sup>-1</sup>

14.04

Bestell-Nr. Order no. Référence	HSK	Spannbereich Capacity d Capacité	A	D
F40.02.10	HSK-F 40	1 - 10 (ER 16)	60	28
F40.02.16	HSK-F 40	1 - 16 (ER 25)	60	42
F50.02.16	HSK-F 50	1 - 16 (ER 25)	70	42
F50.02.20	HSK-F 50	2 - 20 (ER 32)	80	50
F50.02.26	HSK-F 50	3 - 26 (ER 40)	80	63
F63.02.10	HSK-F 63	1 - 10 (ER 16)	60	28
F63.02.16	HSK-F 63	2 - 16 (ER 25)	70	42
F63.02.20	HSK-F 63	2 - 20 (ER 32)	70	50
F63.02.26	HSK-F 63	3 - 26 (ER 40)	75	63
F63.02.10.1	HSK-F 63	1 - 10 (ER 16)	100	28
F63.02.16.1	HSK-F 63	2 - 16 (ER 25)	100	42
F63.02.20.1	HSK-F 63	2 - 20 (ER 32)	100	50
F63.02.26.1	HSK-F 63	3 - 26 (ER 40)	100	63
F63.02.10.2	HSK-F 63	1 - 10 (ER 16)	160	28
F63.02.16.2	HSK-F 63	2 - 16 (ER 25)	160	42
F63.02.20.2	HSK-F 63	2 - 20 (ER 32)	160	50
F63.02.26.2	HSK-F 63	3 - 26 (ER 40)	160	63

**Lieferumfang:** Mit gewuchteter Spannmutter  
**Delivery:** With balanced clamping nut  
**Livraison:** Avec écrou de serrage équilibré







End mill holders DIN 6359 for end mills DIN 1835-B  
Porte-fraises DIN 6359 pour queues cylindriques DIN 1835-B



**Verwendung:**  
Zum Spannen von zylindrischen  
Werkzeugschäften mit seitlicher Spann-  
fläche nach DIN 1835 Form B (Weldon).

**Application:**  
For mounting straight-shank tools with flat  
according to DIN 1835 form B (Weldon).

**Application:**  
Pour le serrage d'outils avec queue  
cylindrique et avec méplat suivant DIN  
1835 forme B (Weldon).

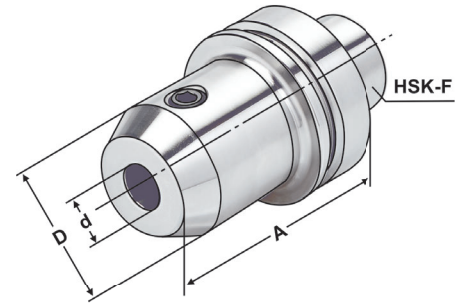

ISO 12164  
(DIN 69893)

HSK - F

$\nabla \leq 0,003$

G2,5  
25.000 min<sup>-1</sup>

14.04

5

Bestell-Nr. Order no. Référence	HSK	d <sup>H4</sup>	A	D
F63.04.06	HSK-F 63	6	65	25
F63.04.08	HSK-F 63	8	65	28
F63.04.10	HSK-F 63	10	65	35
F63.04.12	HSK-F 63	12	80	42
F63.04.14	HSK-F 63	14	80	44
F63.04.16	HSK-F 63	16	80	48
F63.04.18	HSK-F 63	18	80	48
F63.04.20	HSK-F 63	20	80	52
F63.04.25	HSK-F 63	25	110	65
F63.04.32	HSK-F 63	32	110	72

**Hinweis:** Ab d = 25 mit zwei Spannschrauben  
**Note:** From d = 25 on two clamping screws  
**Observation:** A partir de d = 25 avec deux vis de serrage

**Lieferumfang:** Mit Spannschraube  
**Delivery:** With clamping screw  
**Livraison:** Avec vis de serrage



End mill holders DIN 6359 for end mills DIN 1835-E  
Porte-fraises DIN 6359 pour queues cylindriques DIN 1835-E



**Verwendung:**  
Zum Spannen von zylindrischen  
Werkzeugschäften mit geneigter Spannflä-  
che nach DIN 1835 Form E (Whistle Notch).

**Application:**  
For mounting straight-shank tools and  
inclined flat according to DIN 1835 form E  
(Whistle Notch).

**Application:**  
Pour le serrage d'outils avec queue  
cylindrique et avec méplat incliné suivant  
DIN 1835 forme E (Whistle Notch).

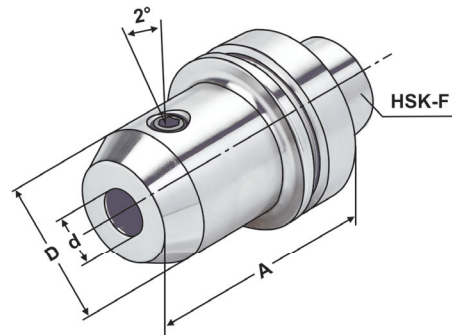

ISO 12164  
(DIN 69893)

HSK - F

$\nabla \leq 0,003$

G2,5  
25.000 min<sup>-1</sup>

14.04

Bestell-Nr.  
Order no.  
Référence

HSK

d<sup>H4</sup>

A

D

F63.05.06	HSK-F 63	6	100	25
F63.05.08	HSK-F 63	8	100	28
F63.05.10	HSK-F 63	10	100	35
F63.05.12	HSK-F 63	12	100	42
F63.05.14	HSK-F 63	14	100	44
F63.05.16	HSK-F 63	16	100	48
F63.05.18	HSK-F 63	18	100	48
F63.05.20	HSK-F 63	20	100	52
F63.05.25	HSK-F 63	25	120	65
F63.05.32	HSK-F 63	32	120	72

5

**Hinweis:** Ab d = 25 mit zwei Spannschrauben  
**Note:** From d = 25 on two clamping screws  
**Observation:** A partir de d = 25 avec deux vis de serrage

**Lieferumfang:** Mit Spannschraube und axialer Verstelle schraube  
**Delivery:** With clamping screw and axial adjustment bolt  
**Livraison:** Avec vis de serrage et vis de butée axiale

## Gewuchtete Ausführung

Balanced type  
Type équilibré



Bestell-Nr. Order no. Référence	Abmessung Size Dimension
---------------------------------------	--------------------------------

**Wuchten auf G 2,5 von vorgewuchteten  
Kemmler-Werkzeugen**  
Balancing at G 2.5 of pre-balanced Kemmler-tools  
Équilibrage sur G 2,5 d'outils Kemmler pré-équilibrés

W25 **Ohne Wuchtprotokoll**  
Without balancing report  
Sans protocole d'équilibrage

W25.2 **Mit Wuchtprotokoll**  
With balancing report  
Avec protocole d'équilibrage

**Wuchten von nicht vorgewuchteten Werkzeugen**  
Balancing of unbalanced tools  
Équilibrage d'outils non-équilibrés

W25.1 **Ohne Wuchtprotokoll**  
Without balancing report  
Sans protocole d'équilibrage





mit vergrößerter Anlagefläche

Shell mill holders DIN 6357 with enlarged contact face  
Porte-fraises à trou lisse DIN 6357 avec face de contact élargie



**Verwendung:**  
Zur Aufnahme von Messerköpfen und Fräsern mit Quernut.

**Application:**  
For mounting milling cutters with transversal groove.

**Application:**  
Pour le serrage de fraises à rainure transversale.

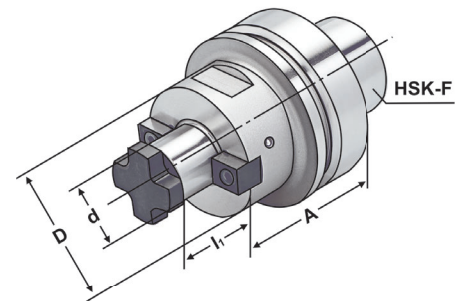

ISO 12164  
(DIN 69893)

HSK - F

$\nabla \leq 0,005$

G2,5  
25.000 min<sup>-1</sup>



5

Bestell-Nr. Order no. Référence	HSK	d <sub>H6</sub>	A	l <sub>1</sub>	D
F63.11.16	HSK-F 63	16	50	17	40
F63.11.22	HSK-F 63	22	50	19	48
F63.11.27	HSK-F 63	27	60	21	60
F63.11.32	HSK-F 63	32	60	24	78
F63.11.40	HSK-F 63	40	100	27	89
F63.11.16.1	HSK-F 63	16	100	17	40
F63.11.22.1	HSK-F 63	22	100	19	48
F63.11.27.1	HSK-F 63	27	100	21	60
F63.11.32.1	HSK-F 63	32	100	24	78
F63.11.16.2	HSK-F 63	16	160	17	40
F63.11.22.2	HSK-F 63	22	160	19	48
F63.11.27.2	HSK-F 63	27	160	21	60

**d = 40:** Für große Planfräser mit vier zusätzlichen Gewindebohrungen nach DIN 2079  
For large diameter face mill cutters with four additional threaded holes according to DIN 2079  
Pour fraises à surfacer à grands diamètres avec quatre trous taraudés additionnels suivant DIN 2079

**Lieferumfang:** Mit Mitnehmersteinen und Kreuzschraube.  
**Delivery:** With drivers and cross head retaining screw.  
**Livraison:** Avec tenons et une vis cruciforme.

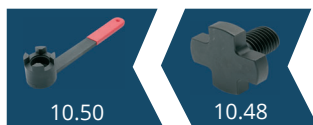

*CNC-Drill chucks for clockwise and counter clockwise rotation*  
Mandrins de perçage CNC pour rotation gauche-droite



**Verwendung:**  
Zur Aufnahme von Werkzeugen mit Zylinderschaft.

**Application:**  
*For mounting tools with straight shanks.*

**Application:**  
Pour le serrage d'outils avec queue cylindrique.

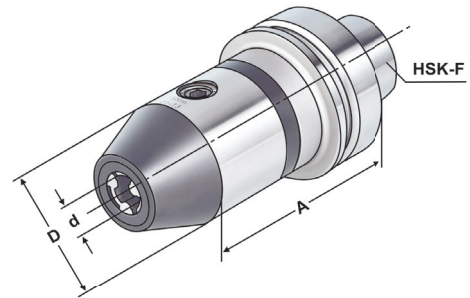

ISO 12164  
(DIN 69893)

HSK - F

$\lambda \leq 0,030$

G2,5  
25.000 min<sup>-1</sup>

 14.04

Bestell-Nr. Order no. Référence	HSK	Spannbereich Capacity Capacité	A	D
F63.15.13	HSK-F 63	1,0 – 13	110	50
F63.15.16	HSK-F 63	2,5 – 16	115	50

5

**Hinweis:** Hohe Präzision und Rundlaufgenauigkeit von  $\leq 0,03$  mm. Sichere Spannung des Werkzeuges durch mechanische Spannkraftverstärkung. Kein selbständiges Lösen der Spannung während der Bearbeitung bei Links- oder Rechtslauf, sowie bei Spindelstop. Spannen und Lösen mit Sechskantschlüssel.

**Note:** *High precision and accurate concentricity of  $\leq 0.03$  mm. Secure gripping of the tool through mechanical amplification of the clamping force. No automatic slackening of the clamping force while machining with either clockwise or counter clockwise rotation or on spindle stop. Clamping and releasing effected by means of an Allen wrench.*

**Observation:** Précision élevée et exactitude de circularité de  $\leq 0,03$  mm. Serrage sûr de l'outil grâce à l'amplification de la force de serrage. Pas de desserrage intempestif en cours d'usinage lors de la rotation la gauche ou la droite, de même qu'en cas d'arrêt de la broche. Serrage et desserrage en utilisant un clé sur à fourche.

**Lieferumfang:** Mit Spannschlüssel  
**Delivery:** *With wrench*  
**Livraison:** Avec clé de serrage



10.23



mit Längenausgleich auf Druck und Zug

Quick change tapping chucks with length compensation on compression and expansion

Mandrins de taraudage à changement rapide avec compensation longitudinale à la compression et traction



Verwendung:

Zur Aufnahme von Schnellwechsel-Einsätzen für Gewindebohrer.

Application:

For the chucking of quick change adaptors for taps.

Application:

Pour le serrage d'adapteurs porte-tarands à changement rapide.

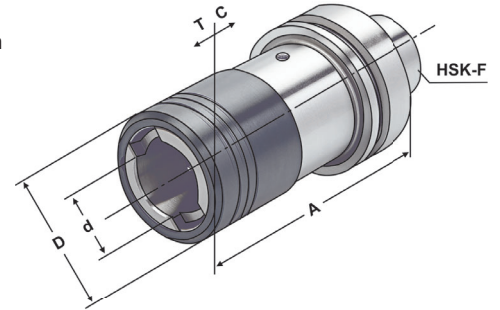

ISO 12164 (DIN 69893)	HSK - F	G2.5 25.000 min <sup>-1</sup>
--------------------------	---------	----------------------------------

Bestell-Nr. Order no. Référence	HSK	Spannbereich Capacity Capacité	Größe Size Taille	A	D	d	C	T
F63.16.12	HSK-F 63	M3 – M14	1	102	36	19	7	7
F63.16.20	HSK-F 63	M5 – M22	2	140	53	31	12	12



**Hinweis:** Für Bearbeitungszentren ohne Synchronspindel.  
**Note:** For machining centres without synchronous spindle.  
**Observation:** Pour centres d'usinage sans broche synchrone.





Adaptor sleeves for MT with tang DIN 6383  
 Douilles de réduction pour CM à tenon DIN 6383



**Verwendung:**  
 Zur Aufnahme von Werkzeugen mit Morsekegelschaft und Austreibblappen nach DIN 228-1 Form B.

**Application:**  
 For mounting tools with Morse taper shank and tang according to DIN 228-1 form B.

**Application:**  
 Pour le serrage d'outils avec queue cône Morse et tenon suivant DIN 228-1 forme B.

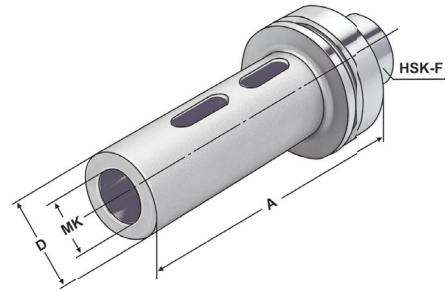

ISO 12164 (DIN 69893)    HSK - F     $\nabla \leq 0,005$     G2,5 25.000 min<sup>-1</sup>

Bestell-Nr. Order no. Référence	HSK	MK MT CM	A	D
F63.07.01	HSK-F 63	1	100	25
F63.07.02	HSK-F 63	2	120	32
F63.07.03	HSK-F 63	3	140	40
F63.07.04	HSK-F 63	4	160	48





Boring bar blanks  
Barres d'alésage



**Verwendung:**  
Zur Herstellung von Sonderwerkzeugen.  
**Application:**  
*For the manufacturing of special tools.*  
**Application:**  
Pour la fabrication d'outils spéciaux.

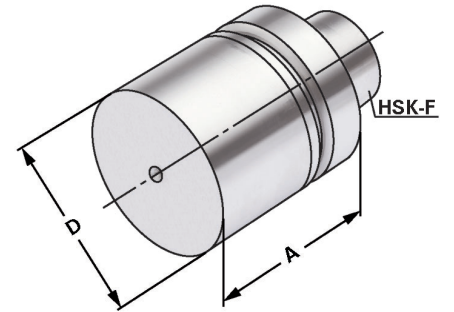

ISO 12164  
(DIN 69893)

HSK - F

Bestell-Nr.  
Order no.  
Référence

HSK

A

D

F63.17.63

HSK-F 63

125

63

F63.17.63.1

HSK-F 63

250

63

5

**Ausführung:** Kegel und Bund gehärtet und geschliffen. Schaft weich zur weiteren Bearbeitung.  
**Version:** *Cone and flange hardened and adjusted. Soft body for later processing.*  
**Version:** Cône et collerette durcis et rectifiés. Corps doux pour un usinage ultérieur.



**Test arbors**  
Mandrins de contrôle



**Verwendung:**  
Zur Abnahme von Werkzeugmaschinen gemäß ISO-Empfehlung R230 oder zur Überprüfung der Werkzeugspindel.

**Application:**  
*For the inspection of machine tools according to ISO recommendation R230 or for testing the tool spindle.*

**Application:**  
Pour l'inspection de machine-outils suite à la recommandation ISO R230 ou pour la vérification de la broche.

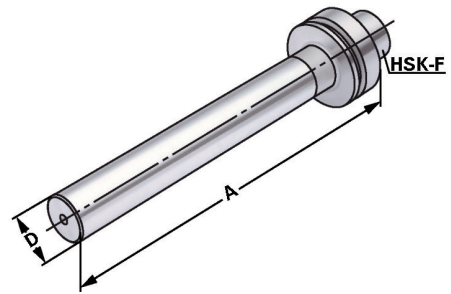

ISO 12164 (DIN 69893)    HSK - F     $\nabla \leq 0,003$

Bestell-Nr. Order no. Référence	HSK	A	D	Toleranz Tolerance Tolérance	max. Rundlaufabweichung max. concentricity deviation Faux-rond max.
F63.18.40	HSK-F 63	250	40	0,003	0,003



**Lieferumfang:** Auslieferung mit Prüfprotokoll  
**Delivery:** Delivery with test certificate  
**Livraison:** Livraison avec rapport d essais

**Holzkasten für Kontrolldorne**

**Wooden box for test arbors**  
Coffret en bois pour mandrins de contrôle



**Verwendung:**  
Zur Aufbewahrung von Kontrolldornen.

**Application:**  
*For the storage of test arbors.*

**Application:**  
Pour la conservation de mandrins de contrôle.



Bestell-Nr. Order no. Référence	Abmessung Size Dimension	für Kegelgrößen for cones pour cônes
701.18	460 × 130 × 115	HSK 32 / 40 / 50 / 63 / 80 / 100





## zum Spannen von HM und HSS Werkzeugschäften

*Shrink chucks 4,5° for mounting of solid carbide and HSS-tool shanks*

Mandrins de frettage 4,5° pour le serrage de queues d'outils carbures de type HM et HSS

**Verwendung:**

Zur Aufnahme von Werkzeugen mit Zylinderschaft.

**Application:**

For mounting straight-shank tools.

**Application:**

Pour le serrage d'outils avec queue cylindrique.

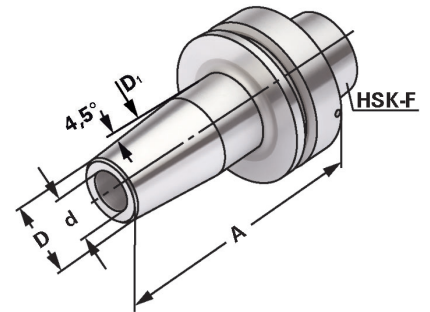
ISO 12164  
(DIN 69893)

HSK - F

 $\nabla \leq 0,003$ G2,5  
25.000 min<sup>-1</sup>

5

Bestell-Nr. Order no. Référence	HSK	d	A	D	D <sub>1</sub>	l <sub>1</sub>	l <sub>2</sub>
F63.70.03	HSK-F 63	3	80	11	15	10	-
F63.70.04	HSK-F 63	4	80	14	22	20	5
F63.70.05	HSK-F 63	5	80	16	22	20	5
F63.70.06	HSK-F 63	6	80	21	27	36	10
F63.70.08	HSK-F 63	8	80	21	27	36	10
F63.70.10	HSK-F 63	10	85	24	32	42	10
F63.70.12	HSK-F 63	12	90	24	32	47	10
F63.70.14	HSK-F 63	14	95	27	34	47	10
F63.70.16	HSK-F 63	16	95	27	34	50	10
F63.70.18	HSK-F 63	18	95	33	42	50	10
F63.70.20	HSK-F 63	20	100	33	42	52	10
F63.70.25	HSK-F 63	25	115	44	54	58	10
F63.70.03.1	HSK-F 63	3	120	11	15	10	-
F63.70.04.1	HSK-F 63	4	120	16	22	20	5
F63.70.05.1	HSK-F 63	5	120	16	22	20	5
F63.70.06.1	HSK-F 63	6	120	21	27	36	10
F63.70.08.1	HSK-F 63	8	120	21	27	36	10
F63.70.10.1	HSK-F 63	10	120	24	32	42	10
F63.70.12.1	HSK-F 63	12	120	24	32	47	10
F63.70.14.1	HSK-F 63	14	120	27	34	47	10
F63.70.16.1	HSK-F 63	16	120	27	34	50	10
F63.70.18.1	HSK-F 63	18	120	33	42	50	10

**Für Ø 3, 4 und 5 mm nur Hartmetallschäfte verwenden!***For Ø 3, 4 and 5 mm only solid carbide tool shanks must be used!*

Pour Ø 3, 4 et 5 mm il faut seulement utiliser de queues d'outils carbures de type HM!

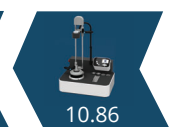
**Hinweis:** Aufnahme für Induktiv-, Kontakt- und Heißluftschumpfgeräte geeignet. Schafttoleranz bei Ø 3, 4 und 5 mm = h<sub>4</sub>, bei Ø 6 – Ø 32 mm = h<sub>6</sub>**Note:** Toolholders suitable for induction-, contact- and hot air shrink units. Ø 3, 4, 5 with h<sub>4</sub>-tolerance and Ø 6 – Ø 32 with h<sub>6</sub>-tolerance**Observation:** Porte-outils convenables pour machines à frotter par induction, par contact, ou par air chaud. Ø 3, 4, 5 avec h<sub>4</sub>-tolerance et Ø 6 – Ø 32 avec h<sub>6</sub>-tolerancel<sub>1</sub> = max. Einstecktiefel<sub>2</sub> = max. Verstellwegl<sub>1</sub> = max. clamping depthl<sub>2</sub> = max. length adjustment rangel<sub>1</sub> = max. profondeur d'insertionl<sub>2</sub> = max. course de réglage

## zum Spannen von HM und HSS Werkzeugschäften

Shrink chucks 4,5° for mounting of solid carbide and HSS-tool shanks

Mandrins de frettage 4,5° pour le serrage de queues d'outils carbures de type HM et HSS



**Verwendung:**  
Zur Aufnahme von Werkzeugen mit Zylinderschaft.

**Application:**  
For mounting straight-shank tools.

**Application:**  
Pour le serrage d'outils avec queue cylindrique.

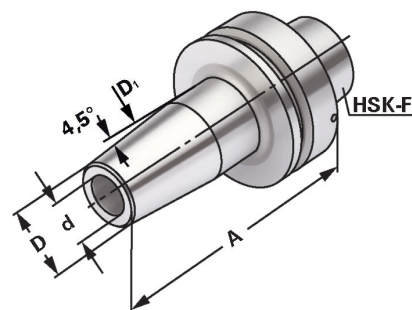
ISO 12164  
(DIN 69893)

HSK - F

 $\lambda \leq 0,003$ G2,5  
25.000 min<sup>-1</sup>

Bestell-Nr. Order no. Référence	HSK	d	A	D	D <sub>1</sub>	l <sub>1</sub>	l <sub>2</sub>
F63.70.04.2	HSK-F 63	4	160	16	22	20	5
F63.70.05.2	HSK-F 63	5	160	16	22	20	5
F63.70.06.2	HSK-F 63	6	160	21	27	36	10
F63.70.08.2	HSK-F 63	8	160	21	27	36	10
F63.70.10.2	HSK-F 63	10	160	24	32	42	10
F63.70.12.2	HSK-F 63	12	160	24	32	47	10
F63.70.14.2	HSK-F 63	14	160	27	34	47	10
F63.70.16.2	HSK-F 63	16	160	27	34	50	10
F63.70.18.2	HSK-F 63	18	160	33	42	50	10
F63.70.20.2	HSK-F 63	20	160	33	42	52	10

5

Für Ø 3, 4 und 5 mm nur Hartmetallschäfte verwenden!

For Ø 3, 4 and 5 mm only solid carbide tool shanks must be used!

Pour Ø 3, 4 et 5 mm il faut seulement utiliser de queues d'outils carbures de type HM!

**Hinweis:** Aufnahme für Induktiv-, Kontakt- und Heißluftschumpfgeräte geeignet.  
Schafttoleranz bei Ø 3, 4 und 5 mm = h<sub>4</sub>, bei Ø 6 – Ø 32 mm = h<sub>6</sub>

**Note:** Toolholders suitable for induction-, contact- and hot air shrink units.  
Ø 3, 4, 5 with h<sub>4</sub>-tolerance and Ø 6 – Ø 32 with h<sub>6</sub>-tolerance

**Observation:** Porte-outils convenables pour machines à fretter par induction,  
par contact, ou par air chaud.  
Ø 3, 4, 5 avec h<sub>4</sub>-tolerance et Ø 6 – Ø 32 avec h<sub>6</sub>-tolerance

l<sub>1</sub> = max. Einstecktiefel<sub>2</sub> = max. Verstellwegl<sub>1</sub> = max. clamping depthl<sub>2</sub> = max. length adjustment rangel<sub>1</sub> = max. profondeur d'insertion l<sub>2</sub> = max. course de réglage

5.43

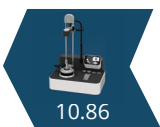

10.86



Hydraulic expansion chucks  
Mandrins expansibles hydrauliques



**Verwendung:**  
Zur Aufnahme von Werkzeugen mit Zylinderschaft nach DIN 1835 Form A+B+E und DIN 6535 Form HA+HB+HE (größer Ø 20 mm nur mit Reduzierung).

**Application:**  
For mounting straight-shank tools acc. DIN 1835 form A+B+E and DIN 6535 form HA+HB+HE (larger).

**Application:**  
Pour le serrage d'outils avec queue cylindrique suivant DIN 1835 forme A+B+E et DIN 6535 forme HA+HB+HE (à partir de dia. 20 mm seulement avec réduction).

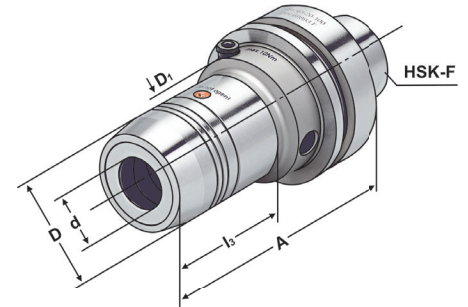

ISO 12164 (DIN 69893)	HSK - F	$\nabla \leq 0,003$	G2,5 25.000 min <sup>-1</sup>	14.04
--------------------------	---------	---------------------	----------------------------------	-------

5

Bestell-Nr. Order no. Référence	HSK	d	A	D	D <sub>1</sub>	l <sub>1</sub>	l <sub>2</sub>	l <sub>3</sub>
F63.H06	HSK-F 63	6	100	26	50	37	10	45
F63.H08	HSK-F 63	8	100	28	50	37	10	44
F63.H10	HSK-F 63	10	100	30	50	42	10	46
F63.H12	HSK-F 63	12	100	32	50	47	10	45,5
F63.H14	HSK-F 63	14	100	34	50	47	10	44
F63.H16	HSK-F 63	16	100	38	50	52	10	44
F63.H18	HSK-F 63	18	100	40	50	52	10	42
F63.H20	HSK-F 63	20	100	42	50	52	10	42
F63.H25	HSK-F 63	25	120	50	50	58	10	26
F63.H32	HSK-F 63	32	125	60	50	62	10	26

Lieferumfang: Mit Spannschlüssel  
Delivery: With wrench  
Livraison: Avec clé de serrage

l<sub>1</sub> = max. Einstecktiefe  
l<sub>1</sub> = max. clamping depth  
l<sub>1</sub> = max. profondeur d'insertion  
l<sub>2</sub> = max. Verstellweg  
l<sub>2</sub> = max. length adjustment range  
l<sub>2</sub> = max. course de réglage

## Gewuchtete Ausführung

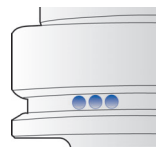

Balanced type  
Type équilibré

Bestell-Nr. Order no. Référence	Abmessung Size Dimension
---------------------------------------	--------------------------------

**Wuchten auf G 2,5 von vorgewuchteten Kemmler-Werkzeugen**  
Balancing at G 2.5 of pre-balanced Kemmler-tools  
Équilibrage sur G 2,5 d'outils Kemmler pré-équilibrés

W25 **Ohne Wuchtprotokoll**  
Without balancing report  
Sans protocole d'équilibrage

W25.2 **Mit Wuchtprotokoll**  
With balancing report  
Avec protocole d'équilibrage

**Wuchten von nicht vorgewuchteten Werkzeugen**  
Balancing of unbalanced tools  
Équilibrage d'outils non-équilibrés

W25.1 **Ohne Wuchtprotokoll**  
Without balancing report  
Sans protocole d'équilibrage





Technische Datenblätter, STEP/STL Modelle für die Simulation der NC-Programme und DXF-Zeichnungen zur Erstellung des Einrichteblattes stehen Online zur Verfügung.

*Technical data sheets, STEP/STL models for the simulation of NC programs and DXF drawings to create the tooling sheet are online available.*

Fiches techniques, STEP/STL modèles techniques pour la simulation de programmes CN et dessins DXF pour créer la feuille d'installation sont disponible online.

Sie können unsere Kataloge entweder direkt im Browser betrachten oder sie auf Ihren PC, Smartphone oder Tablet herunterladen (PDF-Reader notwendig).

*You can view our catalogues either directly in the browser or download to your PC, smartphone or tablet (PDF reader required).*

Vous pouvez consulter nos catalogues directement dans le navigateur ou télécharger sur votre PC, smartphone ou tablet (lecteur PDF requis).



Auf unserer Internetseite können Sie die Lagerverfügbarkeit prüfen - auch auf Mobilgeräten.

*On our website you can check the stock availability - also on mobile devices.*

Vous pouvez également vérifier la disponibilité de nos produits sur le site Internet - ainsi que sur vos appareils

