

TOOL HOLDERS

HSK-T

HSK-T TOOLING SYSTEM

HSK-T 工具系统

HSK-T Boring Bar Holder	004
复合刀具, 镗孔刀夹	004
HSK-T Turning Tools for Facing	005
复合车刀座, 端面加工	005
HSK-T Turning Tools for External and Facing.....	006
复合车刀座, 外径端面加工	006
HSK-T Turning Tools for External and Cut-off.....	007
复合车刀座, 外径切断加工	007
HSK-T Turning Tools for External and Facing.....	008
复合车刀座, 外径端面加工	008
HSK-T Turning Tools for Internal.....	009
复合车刀座, 内孔加工	009
HSK-T Turning Tools for External.....	010
复合车刀座, 外圆加工	010



HSK

HSK-T Boring Bar Holder

复合刀具, 镗孔刀夹

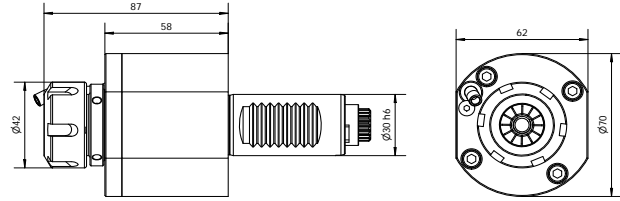

Size	d1	d2	l1	l2
HSK40T-E2-06-055	6	34	55	35
HSK40T-E2-08-055	8	34	55	35
HSK40T-E2-10-055	10	34	55	35
HSK40T-E2-12-055	12	36	55	35
HSK40T-E2-16-070	16	40	70	50
HSK40T-E2-20-085	20	44	85	65
HSK63T-E2-06-060	6	34	60	34
HSK63T-E2-08-060	8	34	60	34
HSK63T-E2-10-060	10	34	60	34
HSK63T-E2-12-060	12	36	60	34
HSK63T-E2-16-075	16	40	75	49
HSK63T-E2-20-075	20	44	75	49
HSK63T-E2-25-075	25	50	75	49
HSK63T-E2-32-090	32	56	90	64
HSK63T-E2-40-090	40	63	90	64
HSK100T-E2-06-070	6	34	70	41
HSK100T-E2-08-070	8	34	70	41
HSK100T-E2-10-070	10	34	70	41
HSK100T-E2-12-070	12	36	70	41
HSK100T-E2-16-085	16	40	85	56
HSK100T-E2-20-085	20	44	85	56
HSK100T-E2-25-085	25	50	85	56
HSK100T-E2-32-100	32	56	100	71
HSK100T-E2-40-100	40	63	100	71
HSK100T-E2-50-120	50	88	120	91

HSK·T Turning Tools for Facing
复合车刀座, 端面加工

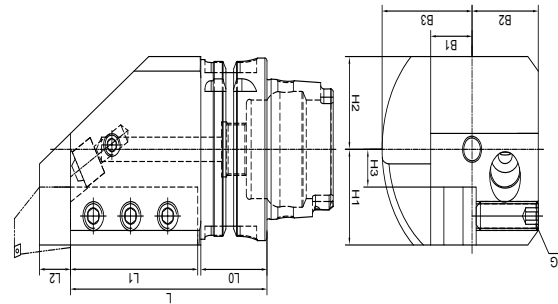
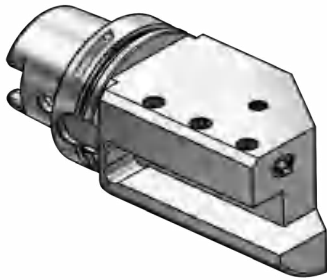

Size	L	L1	L2	B1	B2	B3	H1	H2	H3	L0	G
HSK50T-SBV2020R-95	95	60	15	20	25	43.5	25	25	5	31	M10
HSK50T-SBV2020L-95	95	60	15	20	25	43.5	25	25	5	31	M10
HSK63T-SBV2020R-95	95	60	15	20	32	43.5	33	32	13	32	M10
HSK63T-SBV2020L-95	95	60	15	20	32	43.5	33	32	13	32	M10
HSK63T-SBV2525R-105	105	70	20	25	32	45	30	30	5	32	M12
HSK63T-SBV2525L-105	105	70	20	25	32	45	30	30	5	32	M12
HSK100T-SBV2525R-150	150	110	20	25	37	59	48	43	23	35	M12
HSK100T-SBV2525L-150	150	110	20	25	37	59	48	43	23	35	M12
HSK100T-SBV3232R-150	150	110	20	32	40	68.5	45	43	15	35	M14
HSK100T-SBV3232L-150	150	110	20	32	40	68.5	45	43	15	35	M14

HSK

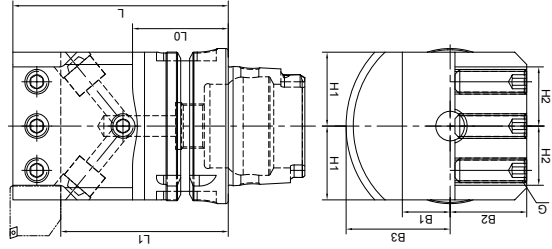
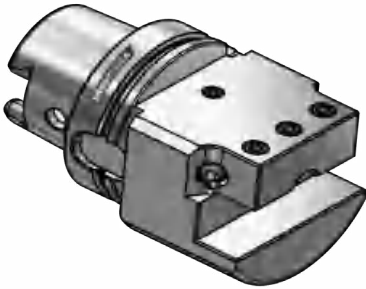
HSK-T Turning Tools for External and Facing
复合车刀座, 外径端面加工

Size	L	L1	B1	B2	B3	H1	H2	L0	G
HSK50T-SBH2020N-90	90	70	20	25	43.5	27.5	-	40	M10
HSK50T-SBH2020N-120	120	100	20	25	43.5	27.5	-	70	M10
HSK63T-SBH2020N-90	90	70	20	32	43.5	30	-	40	M10
HSK63T-SBH2525N-90	90	65	25	32	53	40.5	29.5	40	M12
HSK63T-SBH2525N-120	120	95	25	32	53	40.5	29.5	70	M12
HSK100T-SBH2525N-105	105	80	25	32	59	48	37	35	M12
HSK100T-SBH2525N-150	150	125	25	32	59	48	37	35	M12
HSK100T-SBH3232N-105	105	75	32	40	68.5	57	43	35	M14

HSK-T Turning Tools for External and Cut-off

复合车刀座, 外径切断加工

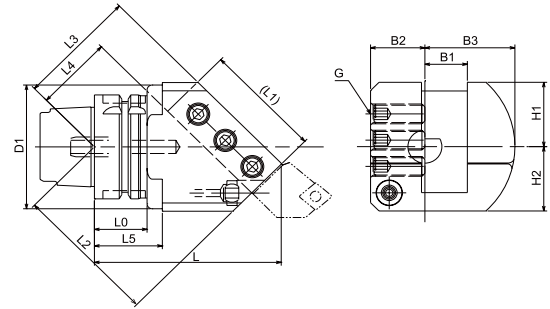

Size	L	L1	L2	L3	L4	L5	D1	B1	B2	B3	H1	H2	L0	G
HSK50T-SBN2020R-110	110	60	83.1	72.8	52.8	-	-	20	25	43.5	35	35	31	M10
HSK50T-SBN2020L-110	110	60	83.1	72.8	52.8	-	-	20	25	43.5	35	35	31	M10
HSK63T-SBN2020R-110	110	60	83.1	72.8	52.8	-	-	20	32	43.5	35	35	32	M10
HSK63T-SBN2020L-110	110	60	83.1	72.8	52.8	-	-	20	32	43.5	35	35	32	M10
HSK63T-SBN2525R-110	110	70	85.2	70.8	45.8	40	90	25	32	53	39	39	32	M12
HSK63T-SBN2525L-110	110	70	85.2	70.8	45.8	40	90	25	32	53	39	39	32	M12
HSK100T-SBN2525R-135	135	70	102.9	88.5	63.5	-	-	25	32	59	43	43	35	M12
HSK100T-SBN2525L-135	135	70	102.9	88.5	63.5	-	-	25	32	59	43	43	35	M12
HSK100T-SBN3232R-140	140	85	109.9	89	59	-	-	32	37	68.5	48	43	35	M14
HSK100T-SBN3232L-140	140	85	109.9	89	59	-	-	32	37	68.5	48	43	35	M14

HSK

HSK-T Turning Tools for External and Facing

复合车刀座, 外径端面加工

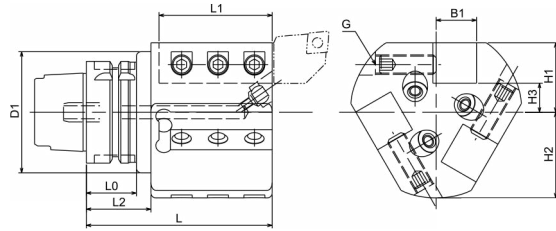
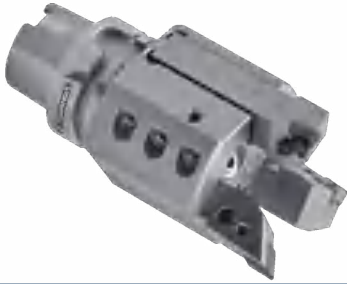

Size	L	L1	L2	D1	B1	H1	H2	H3	L0	G
HSK50T-SBT2020R-95	95	60	-	-	20	35	43.5	15	31	M10
HSK50T-SBT2020L-95	95	60	-	-	20	35	43.5	15	31	M10
HSK63T-SBT2020R-95	95	60	-	-	20	35	43.5	15	32	M10
HSK63T-SBT2020L-95	95	60	-	-	20	35	43.5	15	32	M10
HSK63T-SBT2525R-115	115	70	40	90	25	43	53	18	32	M12
HSK63T-SBT2525L-115	115	70	40	90	25	43	53	18	32	M12
HSK100T-SBT2525R-150	150	110	-	-	25	48	59	23	35	M12
HSK100T-SBT2525L-150	150	110	-	-	25	48	59	23	35	M12

HSK-T Turning Tools for Internal
复合车刀座, 内孔加工

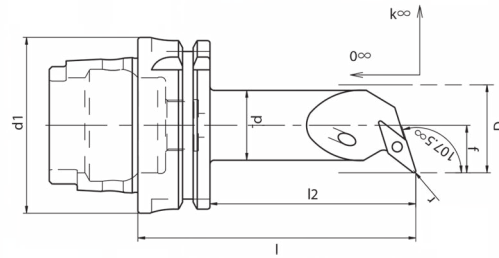

Size	d	l	l2	f	k°	D	r	Inserts N.
HSK63T-SVQBR11-85	20	85	59	13	-8	25	0.4	VB..1102..
HSK63T-SVQBL11-85	20	85	59	13	-8	25	0.4	VB..1102..
HSK63T-SVQBR11-100	25	100	74	17	-5	32	0.4	VB..1102..
HSK63T-SVQBL11-100	25	100	74	17	-5	32	0.4	VB..1102..
HSK63T-SVQBR16-120	32	120	94	22	-10	40	0.8	VB..1604..
HSK63T-SVQBL16-120	32	120	94	22	-10	40	0.8	VB..1604..
HSK63T-SVQBR16-140	40	140	114	27	-10	50	0.8	VB..1604..
HSK63T-SVQBL16-140	40	140	114	27	-10	50	0.8	VB..1604..

HSK

HSK-T Turning Tools for External 复合车刀座, 外圆加工

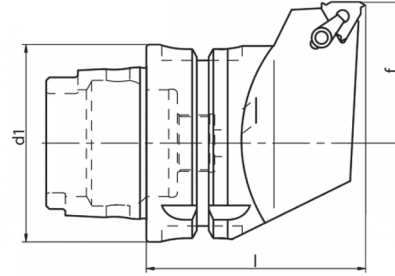

Size	l	f	r	Inserts N.
HSK40T-SDJCR11-50	50	27	0.8	DC..11T3..
HSK40T-SDJCL11-50	50	27	0.8	DC..11T3..
HSK50T-SDJCR11-60	60	35	0.8	DC..11T3..
HSK50T-SDJCL11-60	60	35	0.8	DC..11T3..
HSK63T-SDJCR11-70	70	45	0.8	DC..11T3..
HSK63T-SDJCL11-70	70	45	0.8	DC..11T3..

