

BORING

TOOL HOLDERS

CK 镗刀柄系列

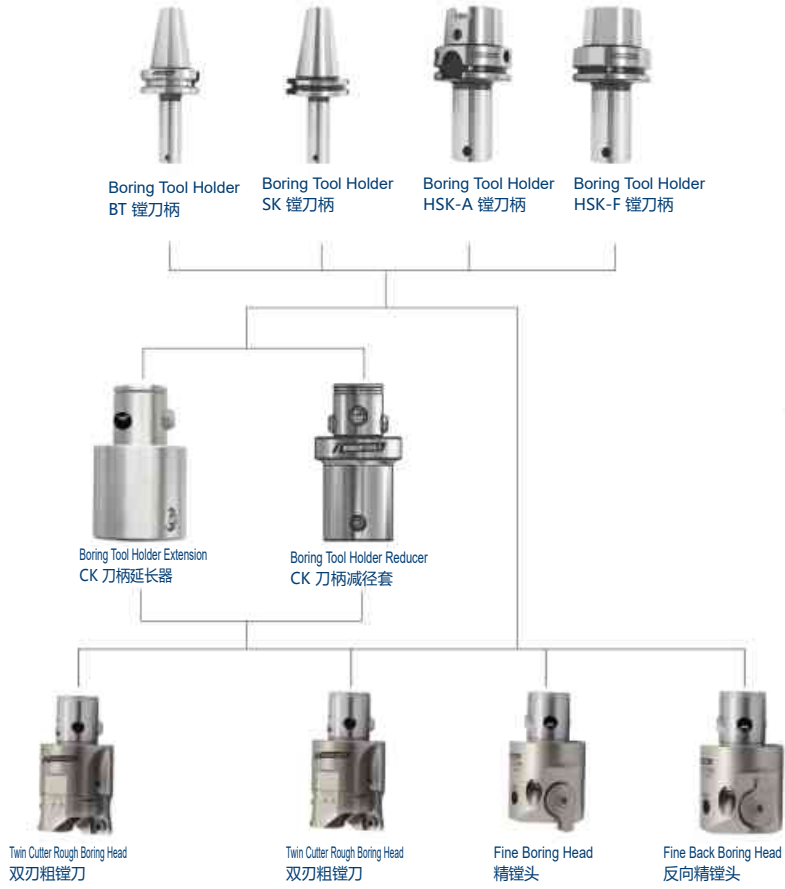

桥镗刀柄系列

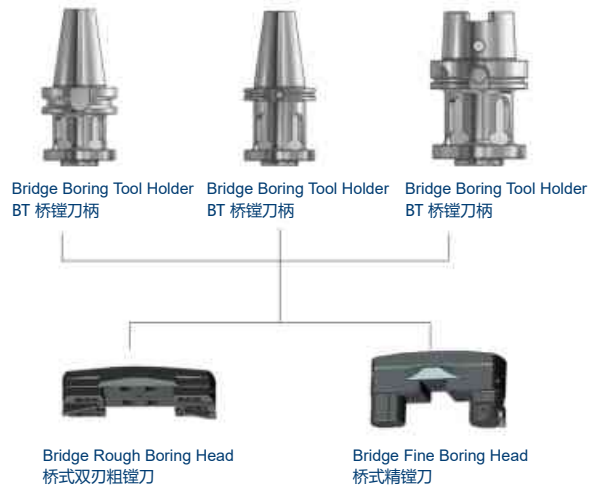

BORING TOOLING SYSTEM BORING 工具系统

Boring Tool Holder.....	004
镗刀柄.....	004
Boring Tool Holder Extension.....	012
CK 刀柄延长器.....	012
Boring Tool Holder Reducer.....	013
CK 刀柄减径套.....	013
Twin Cutter Rough Boring Head	014
双刃粗镗刀.....	014
Bridge Boring Tool Holder.....	016
BST 桥镗刀柄.....	016
Bridge Rough Boring Head.....	019
桥式双刃粗镗刀.....	019
Bridge Fine Boring Head	020
桥式精镗刀.....	020
Fine Boring Head.....	021
精镗头.....	021
Fine Back Boring Head.....	022
反向精镗头.....	022
Small Fine Boring Head	023
精镗小刀夹.....	023



Boring Tool Holder

镗刀柄

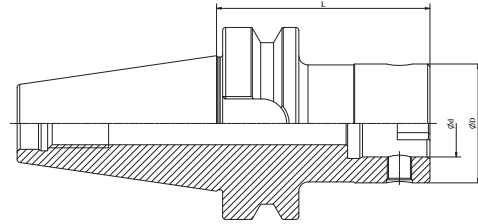

Size	CK No.	D	d	L
BT30-CK1-55	CK1	19	11	55
BT30-CK1-70	CK1	19	11	70
BT30-CK2-80	CK2	24	14	80
BT30-CK3-80	CK3	31	18	80
BT30-CK4-70	CK4	39	22	70
BT30-CK5-70	CK5	50	28	70
BT30-CK6-60	CK6	64	36	60
BT40-CK1-70	CK1	19	11	70
BT40-CK1-100	CK1	19	11	100
BT40-CK1-130	CK1	19	11	130
BT40-CK2-75	CK2	24	14	75
BT40-CK2-100	CK2	24	14	100
BT40-CK2-130	CK2	24	14	130
BT40-CK3-80	CK3	31	18	80
BT40-CK3-100	CK3	31	18	100
BT40-CK3-135	CK3	31	18	135
BT40-CK3-165	CK3	31	18	165
BT40-CK4-70	CK4	39	22	70
BT40-CK4-100	CK4	39	22	100
BT40-CK4-150	CK4	39	22	150
BT40-CK4-170	CK4	39	22	170
BT40-CK5-80	CK5	50	28	80
BT40-CK5-150	CK5	50	28	150
BT40-CK5-180	CK5	50	28	180
BT40-CK6-100	CK6	64	36	100
BT40-CK6-150	CK6	64	36	150
BT40-CK6-180	CK6	64	36	180

Boring Tool Holder 镗刀柄

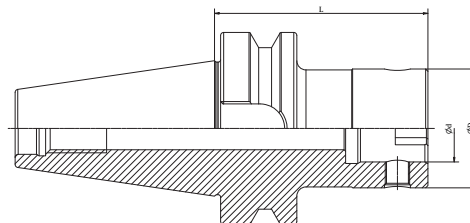

Size	CK No.	D	d	L
BT50-CK1-80	CK1	19	11	80
BT50-CK1-115	CK1	19	11	115
BT50-CK1-145	CK1	19	11	145
BT50-CK2-80	CK2	24	14	80
BT50-CK2-105	CK2	24	14	105
BT50-CK2-135	CK2	24	14	135
BT50-CK2-165	CK2	24	14	165
BT50-CK3-85	CK3	31	18	85
BT50-CK3-110	CK3	31	18	110
BT50-CK3-140	CK3	31	18	140
BT50-CK3-170	CK3	31	18	170
BT50-CK4-100	CK4	39	22	100
BT50-CK4-160	CK4	39	22	160
BT50-CK4-205	CK4	39	22	205
BT50-CK5-90	CK5	50	28	90
BT50-CK5-165	CK5	50	28	165
BT50-CK5-210	CK5	50	28	210
BT50-CK5-270	CK5	50	28	270
BT50-CK6-85	CK6	64	36	85
BT50-CK6-155	CK6	64	36	155
BT50-CK6-215	CK6	64	36	215
BT50-CK6-250	CK6	64	36	250
BT50-CK6-300	CK6	64	36	300
BT50-CK6-350	CK6	64	36	350
BT50-CK7-85	CK7	90	46	85
BT50-CK7-100	CK7	90	46	100
BT50-CK7-180	CK7	90	46	180
BT50-CK7-250	CK7	90	46	250
BT50-CK7-320	CK7	90	46	320
BT50-CK7-350	CK7	90	46	350

Boring Tool Holder

镗刀柄

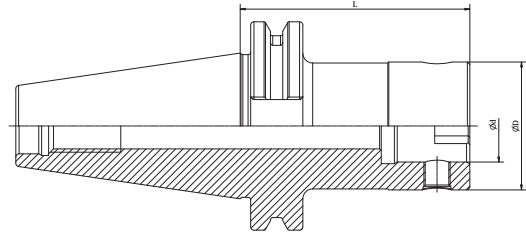

Size	CK No.	D	d	L
SK30-CK1-70	CK1	19	11	70
SK30-CK2-70	CK2	24	14	70
SK30-CK3-75	CK3	31	18	75
SK30-CK4-50	CK4	39	22	50
SK30-CK5-50	CK5	50	28	50
SK30-CK6-60	CK6	64	36	60
SK40-CK1-70	CK1	19	11	70
SK40-CK1-100	CK1	19	11	100
SK40-CK2-50	CK2	24	14	50
SK40-CK2-100	CK2	24	14	100
SK40-CK3-50	CK3	31	18	50
SK40-CK3-100	CK3	31	18	100
SK40-CK3-135	CK3	31	18	135
SK40-CK3-165	CK3	31	18	165
SK40-CK4-50	CK4	39	22	20
SK40-CK4-100	CK4	39	22	100
SK40-CK4-150	CK4	39	22	150
SK40-CK5-80	CK5	50	28	50
SK40-CK5-100	CK5	50	28	100
SK40-CK5-150	CK5	50	28	150
SK40-CK5-180	CK5	50	28	180
SK40-CK6-90	CK6	64	36	90
SK40-CK6-150	CK6	64	36	150
SK40-CK6-180	CK6	64	36	180
SK40-CK7-100	CK7	90	46	100

Boring Tool Holder
镗刀柄

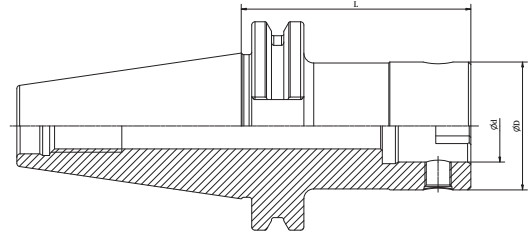

Size	CK No.	D	d	L
SK50-CK1-80	CK1	19	11	80
SK50-CK2-80	CK2	24	14	80
SK50-CK2-105	CK2	24	14	105
SK50-CK2-135	CK2	24	14	135
SK50-CK2-165	CK2	24	14	165
SK50-CK3-85	CK3	31	18	85
SK50-CK3-110	CK3	31	18	110
SK50-CK3-140	CK3	31	18	140
SK50-CK3-170	CK3	31	18	170
SK50-CK4-70	CK4	39	22	70
SK50-CK4-100	CK4	39	22	100
SK50-CK4-160	CK4	39	22	160
SK50-CK4-200	CK4	39	22	200
SK50-CK5-90	CK5	50	28	90
SK50-CK5-160	CK5	50	28	160
SK50-CK5-210	CK5	50	28	210
SK50-CK5-250	CK5	50	28	250
SK50-CK6-85	CK6	64	36	85
SK50-CK6-160	CK6	64	36	160
SK50-CK6-200	CK6	64	36	200
SK50-CK6-250	CK6	64	36	250
SK50-CK6-300	CK6	64	36	300
SK50-CK7-85	CK7	90	46	85
SK50-CK7-150	CK7	90	46	150
SK50-CK7-210	CK7	90	46	210
SK50-CK7-250	CK7	90	46	250
SK50-CK7-300	CK7	90	46	300
SK50-CK7-350	CK7	90	46	350

Boring Tool Holder

镗刀柄

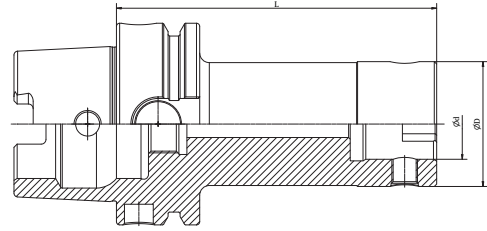

Size	CK No.	D	d	L
HSK40A-CK1-75	CK1	19	11	75
HSK40A-CK2-85	CK2	24	14	85
HSK40A-CK3-80	CK3	31	18	80
HSK40A-CK4-75	CK4	39	22	75
HSK50A-CK1-75	CK1	19	11	75
HSK50A-CK2-85	CK2	24	14	85
HSK50A-CK3-80	CK3	31	18	80
HSK50A-CK4-75	CK4	39	22	75
HSK50A-CK5-85	CK5	50	28	85

Boring Tool Holder
镗刀柄

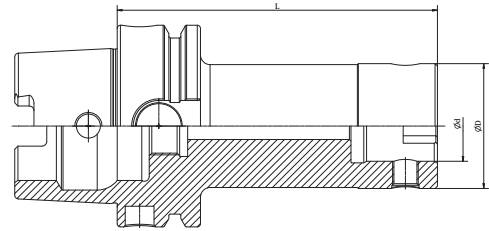

Size	CK No.	D	d	L
HSK63A-CK1-70	CK1	19	11	70
HSK63A-CK1-100	CK1	19	11	100
HSK63A-CK2-75	CK2	24	14	75
HSK63A-CK2-100	CK2	24	14	100
HSK63A-CK2-130	CK2	24	14	130
HSK63A-CK3-80	CK3	31	18	80
HSK63A-CK3-100	CK3	31	18	100
HSK63A-CK3-135	CK3	31	18	135
HSK63A-CK3-165	CK3	31	18	165
HSK63A-CK4-70	CK4	39	22	70
HSK63A-CK4-100	CK4	39	22	100
HSK63A-CK4-150	CK4	39	22	150
HSK63A-CK4-170	CK4	39	22	170
HSK63A-CK5-80	CK5	50	28	80
HSK63A-CK5-100	CK5	50	28	100
HSK63A-CK5-150	CK5	50	28	150
HSK63A-CK5-180	CK5	50	28	180
HSK63A-CK6-100	CK6	64	36	100
HSK63A-CK6-150	CK6	64	36	150
HSK63A-CK6-180	CK6	64	36	180

Boring Tool Holder

镗刀柄

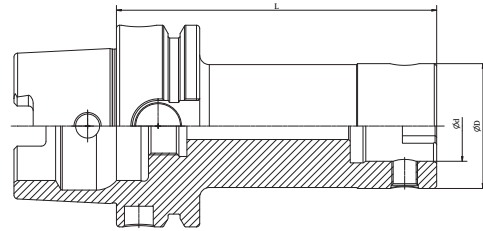

Size	CK No.	D	d	L
HSK100A-CK1-115	CK1	19	11	115
HSK100A-CK1-145	CK1	19	11	145
HSK100A-CK2-105	CK2	24	14	105
HSK100A-CK2-135	CK2	24	14	135
HSK100A-CK2-165	CK2	24	14	165
HSK100A-CK3-110	CK3	31	18	110
HSK100A-CK3-140	CK3	31	18	140
HSK100A-CK3-170	CK3	31	18	170
HSK100A-CK4-100	CK4	39	22	100
HSK100A-CK4-160	CK4	39	22	160
HSK100A-CK4-205	CK4	39	22	205
HSK100A-CK5-90	CK5	50	28	90
HSK100A-CK5-165	CK5	50	28	165
HSK100A-CK5-210	CK5	50	28	210
HSK100A-CK5-270	CK5	50	28	270
HSK100A-CK6-85	CK6	64	36	85
HSK100A-CK6-155	CK6	64	36	155
HSK100A-CK6-215	CK6	64	36	215
HSK100A-CK6-250	CK6	64	36	250
HSK100A-CK6-300	CK6	64	36	300

Boring Tool Holder
镗刀柄

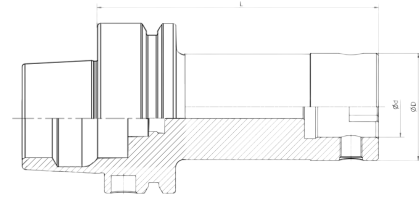

Size	CK No.	D	L
HSK63F-CK1-78	CK1	19	77.5
HSK63F-CK2-90	CK2	24	89.5
HSK63F-CK3-100	CK3	31	100
HSK63F-CK4-93	CK4	39	93
HSK63F-CK5-83	CK5	50	83

Boring Tool Holder Extension CK 刀柄延长器

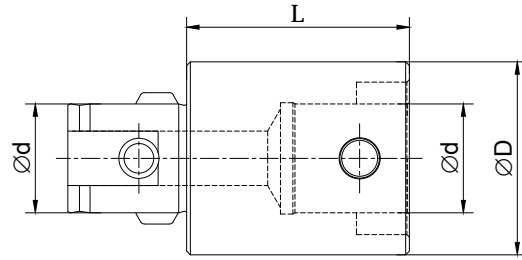

Size	CK No.	D	L
CK11-20	CK1	19	20
CK11-30	CK1	19	30
CK22-30	CK2	24	30
CK22-45	CK2	24	45
CK33-30	CK3	31	30
CK33-45	CK3	31	45
CK44-45	CK4	39	45
CK44-60	CK4	39	60
CK55-60	CK5	50	60
CK55-90	CK5	50	90
CK66-60	CK6	64	60
CK66-100	CK6	64	100
CK77-105	CK7	90	105

Usage: connect boring tool holder and boring head, to extend the working depth.

Boring Tool Holder Reducer CK 刀柄减径套

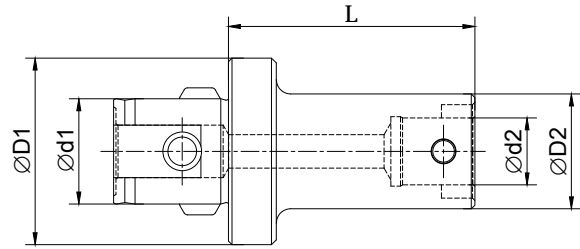

Size	CK No.1	CK No.2	D1	D2	L
CK21- 65	CK2	CK1	24	19	36
CK31- 60	CK3	CK1	31	19	40.5
CK32- 60	CK3	CK2	31	24	34.5
CK41- 75	CK4	CK1	39	19	57.5
CK42- 75	CK4	CK2	39	24	51.5
CK43- 75	CK4	CK3	39	31	47
CK51- 70	CK5	CK1	50	19	57.5
CK52- 70	CK5	CK2	50	24	51.5
CK52-100	CK5	CK2	50	24	81.5
CK53- 70	CK5	CK3	50	31	47
CK53-100	CK5	CK3	50	31	88
CK54- 70	CK5	CK4	50	39	40
CK54-100	CK5	CK4	50	39	70
CK61- 65	CK6	CK1	64	19	66.5
CK62- 80	CK6	CK2	64	24	60.6
CK62-115	CK6	CK2	64	24	95.5
CK63- 80	CK6	CK3	64	31	56
CK63-115	CK6	CK3	64	31	91
CK64- 80	CK6	CK4	64	39	49
CK64-115	CK6	CK4	64	39	84
CK65- 80	CK6	CK5	64	50	39
CK65-115	CK6	CK5	64	50	74
CK76-160	CK7	CK6	90	64	106

Usage: to connect with small size boring head.

Twin Cutter Rough Boring Head 双刃粗镗刀 (装 CC 刀片)

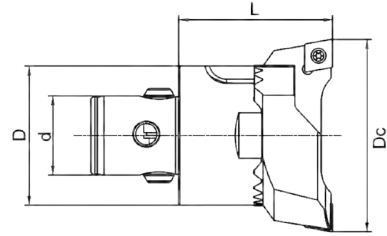

Boring Head Size	Dc	D	d	L	CK No.	Insert Seat Size	Insert	Screw	Key
CK1-R2026-33	20-26	19	11	33	CK1	2026-CC06	CC..0602	M2.5X6	T8
CK2-R2533-36	25-33	24	14	36	CK2	2533-CC06	CC..0602	M2.5X6	T8
CK3-R3242-40	32-42	31	18	40	CK3	3242-CC09	CC..09T3	M3.5X9	T15
CK4-R4154-47	41-54	39	22	47	CK4	4154-CC09	CC..09T3	M3.5X9	T15
CK5-R5370-58	53-70	50	28	58	CK5	5370-CC12	CC..1204	M5X12	T20
CK6-R68110-72	68-90	64	36	72	CK6	6890-CC12	CC..1204	M5X12	T20
CK6-R68110-72	88-110	64	36	72	CK6	88110-CC12	CC..1204	M5X12	T20
CK6-R98153-72	98-126	64	36	72	CK6	98126-CC12	CC..1204	M5X12	T20
CK6-R98153-72	125-153	64	36	72	CK6	125153-CC12	CC..1204	M5X12	T20
CK6-R148203-72	148-176	64	36	72	CK6	148176-CC12	CC..1204	M5X12	T20
CK6-R148203-72	175-203	64	36	72	CK6	175203-CC12	CC..1204	M5X12	T20
CK7-R98153-87	98-126	90	46	87	CK7	98126-CC12	CC..1204	M5X12	T20
CK7-R98153-87	125-153	90	46	87	CK7	125153-CC12	CC..1204	M5X12	T20
CK7-R148203-117	148-176	90	46	117	CK7	148176-CC12	CC..1204	M5X12	T20
CK7-R148203-117	175-203	90	46	117	CK7	175203-CC12	CC..1204	M5X12	T20

Delivery: inserts excluded, please purchase separately.
Please specify boring head and insert seat size.

Twin Cutter Rough Boring Head 双刃粗镗刀 (装 SC 刀片)

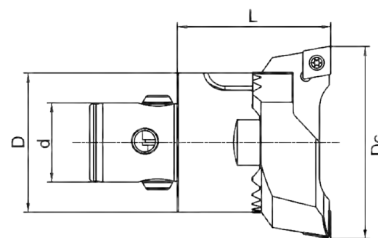

Boring Head Size	Dc	D	d	L	CK No.	Insert Seat Size	Insert	Screw	Key
CK1-R2026-33	20-26	19	11	33	CK1	2026-SC06	SC..0602	M2.5X6	T8
CK2-R2533-36	25-33	24	14	36	CK2	2533-SC06	SC..0602	M2.5X6	T8
CK3-R3242-40	32-42	31	18	40	CK3	3242-SC09	SC..09T3	M3.5X9	T15
CK4-R4154-47	41-54	39	22	47	CK4	4154-SC09	SC..09T3	M3.5X9	T15
CK5-R5370-58	53-70	50	28	58	CK5	5370-SC12	SC..1204	M5X12	T20
CK6-6890-SC12-72	68-90	64	36	72	CK6	6890-SC12	SC..1204	M5X12	T20
CK6-88110-SC12-72	88-110	64	36	72	CK6	88110-SC12	SC..1204	M5X12	T20
CK6-98126-SC12-72	98-126	64	36	72	CK6	98126-SC12	SC..1204	M5X12	T20
CK6-125153-SC12-72	125-153	64	36	72	CK6	125153-SC12	SC..1204	M5X12	T20
CK6-148176-SC12-72	148-176	64	36	72	CK6	148176-SC12	SC..1204	M5X12	T20
CK6-175203-SC12-72	175-203	64	36	72	CK6	175203-SC12	SC..1204	M5X12	T20
CK7-98126-SC12-87	98-126	90	46	87	CK7	98126-SC12	SC..1204	M5X12	T20
CK7-125153-SC12-87	125-153	90	46	87	CK7	125153-SC12	SC..1204	M5X12	T20
CK7-148176-SC12-117	148-176	90	46	117	CK7	148176-SC12	SC..1204	M5X12	T20
CK7-175203-SC12-117	175-203	90	46	117	CK7	175203-SC12	SC..1204	M5X12	T20

Delivery: inserts excluded, please purchase separately.
Please specify boring head and insert seat size.

Bridge Boring Tool Holder BST 桥镗刀柄

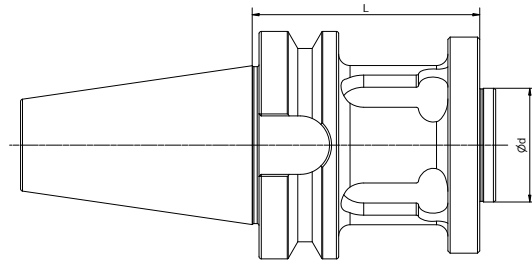

Size	D	d	L
BT40-BST-100	94	50	100
BT40-BST-150	94	50	150
BT50-BST-100	94	50	100
BT50-BST-150	94	50	150
BT50-BST-200	94	50	200
BT50-BST-250	94	50	300
BT50-BST-300	94	50	350

Bridge Boring Tool Holder
BST 桥镗刀柄

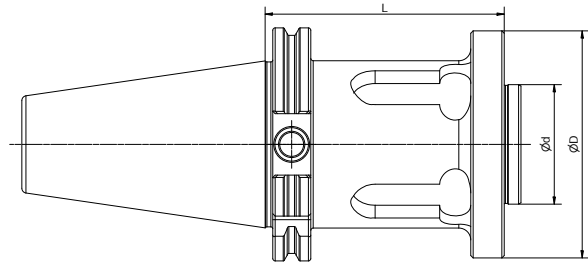

Size	D	d	L
SK50-BST-100	94	50	100
SK50-BST-150	94	50	150
SK50-BST-200	94	50	200

Bridge Boring Tool Holder BST 桥镗刀柄

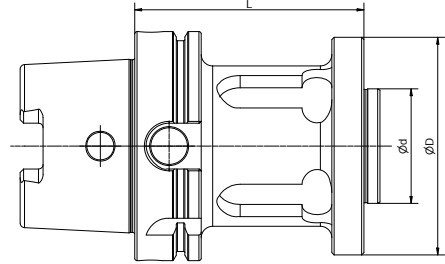

Size	D	d	L
HSK100A-BST-100	94	50	100
HSK100A-BST-150	94	50	150
HSK100A-BST-200	94	50	200
HSK100A-BST-250	94	50	300
HSK100A-BST-300	94	50	350

Bridge Rough Boring Head 桥式双刃粗镗刀

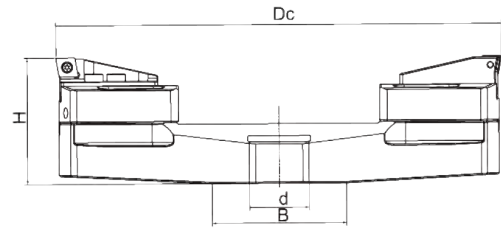

Boring Head Size	Dc	H	d	B	Bridge	Clamp Base	Insert Seat Size
BR200300-40R	200-300	85	40	88	200300.40R	BR7080-28	BR28-15-CC12
BR300400-40R	300-400	85	40	88	300400.40R	BR7080-28	BR28-15-CC12
BR400500-60R	400-500	90	60	130	400500.60R	BR7080-28	BR28-15-CC12
BR500600-60R	500-600	95	60	130	500600.60R	BR7080-28	BR28-15-CC12
BR600700-60R	600-700	100	60	130	600700.60R	BR7080-28	BR28-15-CC12

Delivery: inserts excluded, please purchase separately.

Bridge Fine Boring Head 桥式精镗刀

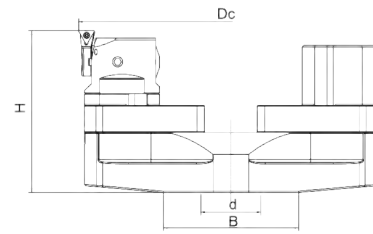

Boring Head Size	Dc	H	d	B	Bridge	Clamp Base	Balance Weight	Insert Seat Size
BF200300-40R	200-300	107	40	88	200300.40R	BF7080-34	BF7080-66	F5-1
BF300400-40R	300-400	107	40	88	300400.40R	BF7080-34	BF7080-66	F5-1
BF400500-60R	400-500	112	60	130	400500.60R	BF7080-34	BF7080-66	F5-2
BF500600-60R	500-600	117	60	130	500600.60R	BF7080-34	BF7080-66	F5-2
BF600700-60R	600-700	121	60	130	600700.60R	BF7080-34	BF7080-66	F5-3

Delivery: insert excluded, please purchase separately.

Fine Boring Head

精镗头

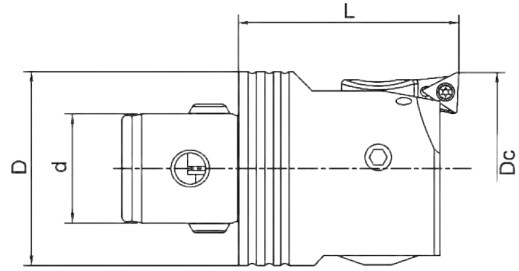

Boring Head Size	Dc	D	d	L	CK No.	Insert Seat Size	Insert
CK1-F2036-33	20-26	19	11	33	CK1	F1-1	TP08
CK1-F2036-33	25-31	19	11	33	CK1	F1-2	TP08
CK1-F2036-33	30-36	19	11	33	CK1	F1-3	TP08
CK2-F2547-36	25-33	24	14	36	CK2	F2-1	TP08
CK2-F2547-36	32-40	24	14	36	CK2	F2-2	TP08
CK2-F2547-36	39-47	24	14	36	CK2	F2-3	TP08
CK3-F3260-40	32-42	31	18	40	CK3	F3-1	TP08
CK3-F3260-40	41-51	31	18	40	CK3	F3-2	TP08
CK3-F3260-40	50-60	31	18	40	CK3	F3-3	TP08
CK4-F4166-46	41-54	39	22	46	CK4	F4-1	TC11
CK4-F4166-46	50-63	39	22	46	CK4	F4-2	TC11
CK4-F4166-46	61-74	39	22	46	CK4	F4-3	TC11
CK5-F5395-57	53-70	50	28	57	CK5	F5-1	TC11
CK5-F5395-57	65-82	50	28	57	CK5	F5-2	TC11
CK5-F5395-57	78-95	50	28	57	CK5	F5-3	TC11
CK6-F68150-71	68-100	64	36	71	CK6	F6-1	TC11
CK6-F68150-71	94-126	64	36	71	CK6	F6-2	TC11
CK6-F68150-71	118-150	64	36	71	CK6	F6-3	TC11
CK6-F100203-71	100-153	64	36	71	CK6	F6-1	TC11
CK6-F100203-71	126-179	64	36	71	CK6	F6-2	TC11
CK6-F100203-71	150-203	64	36	71	CK6	F6-3	TC11
CK7-F100203-71	100-153	90	46	117	CK7	F6-1	TC11
CK7-F100203-71	126-179	90	46	117	CK7	F6-2	TC11
CK7-F100203-71	150-203	90	46	117	CK7	F6-3	TC11

Delivery:

F*-1 insert seat is included, please order F*-2 and F*-3 separately.

Insert excluded, please purchase separately.

Fine Back Boring Head 反向精镗头

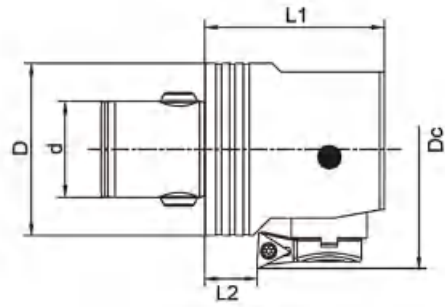

Boring Head Size	Dc	D	d	L1	L2	CK No.	Insert Seat Size	Insert
CK1-FB2036-33	31-31	19	11	33	10.5	CK1	F1-2	TP08
CK1-FB2036-33	30-36	19	11	33	10.5	CK1	F1-3	TP08
CK2-FB2547-36	36-40	24	14	36	11.5	CK2	F2-2	TP08
CK2-FB2547-36	39-47	24	14	36	11.5	CK2	F2-3	TP08
CK3-FB3260-40	46-51	31	18	40	10	CK3	F3-2	TP08
CK3-FB3260-40	50-60	31	18	40	10	CK3	F3-3	TP08
CK4-FB4166-46	53-63	39	22	46	14	CK4	F4-2	TC11
CK4-FB4166-46	61-74	39	22	46	14	CK4	F4-3	TC11
CK5-FB5395-57	62-70	50	28	57	19	CK5	F5-1	TC11
CK5-FB5395-57	65-82	50	28	57	19	CK5	F5-2	TC11
CK5-FB5395-57	78-95	50	28	57	19	CK5	F5-3	TC11
CK6-FB68150-71	80-100	64	36	71	22	CK6	F6-1	TC11
CK6-FB68150-71	94-126	64	36	71	22	CK6	F6-2	TC11
CK6-FB68150-71	118-150	64	36	71	22	CK6	F6-3	TC11
CK6-FB100203-71	112-153	64	36	71	22	CK6	F6-1	TC11
CK6-FB100203-71	126-179	64	36	71	22	CK6	F6-2	TC11
CK6-FB100203-71	150-203	64	36	71	22	CK6	F6-3	TC11
CK7-FB100203-71	112-153	90	46	71	38	CK7	F6-1	TC11
CK7-FB100203-71	126-179	90	46	71	38	CK7	F6-2	TC11
CK7-FB100203-71	150-203	90	46	71	38	CK7	F6-3	TC11

Delivery:

Insert excluded, please purchase separately.

Small Fine Boring Head 精镗小刀夹

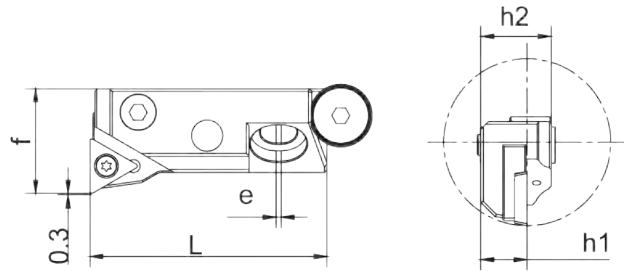

Size	Degree	Dmin	L	h1	h2	e	f	r	Insert
DF-1695L-CC06	95	28	45.5	8.8	13.5	1	16	0.4	CC..0602..
DF-1695R-CC06	95	28	45.5	8.8	13.5	1	16	0.4	CC..0602..
DF-1695L-TP09	95	28	45.5	8.8	13.5	1	16	0.4	TP..0902..
DF-1695R-TP09	95	28	45.5	8.8	13.5	1	16	0.4	TP..0902..
DF-2095L-TC11	95	36	45.5	8.8	13.5	1	20	0.4	TC..1102..
DF-2095R-TC11	95	36	45.5	8.8	13.5	1	20	0.4	TC..1102..
DF-1690L-CC06	90	28	45.5	8.8	13.5	1	16	0.4	CC..0602..
DF-1690R-CC06	90	28	45.5	8.8	13.5	1	16	0.4	CC..0602..
DF-1690L-TP09	90	28	45.5	8.8	13.5	1	16	0.4	TP..0902..
DF-1690R-TP09	90	28	45.5	8.8	13.5	1	16	0.4	TP..0902..
DF-2090L-TC11	90	36	45.5	8.8	13.5	1	20	0.4	TC..1102..
DF-2090R-TC11	90	36	45.5	8.8	13.5	1	20	0.4	TC..1102..

Delivery: insert excluded, please purchase separately.