

E460N

TOOL PRESSETTER





Interchangeable revolving spindle with mechanical rotation brake. Vacuum tool clamping. Two preloaded ball cages allow a concentricity accuracy within 4 μ m



Micrometric registration of X and Z axes by means of two wheels which are essential for the collimation of the measure both with a fixed target function and in self-collimation.



Manual axes movement. Axis unclamping by means of a single pneumatic control system.

X and Z axes block management with control maximum speed of translation 2mm/sec.



Base and column made of ground granite. The thermal inertia of this material allows the machine to be placed directly in the shop. Mechanical elements manufactured from stainless steel.



Camera system for measuring and inspection procedures. C-MOS sensor, punctiform and toroidal red light double illuminator. Telecentric optic system with low F/Number.



Large 15" touch screen for the best visualization of the tools and simple management functions to operate the measuring machine.



New electronic control: a powerful fanless PC with Linux operating system for the integrated management of the functions of measurement / inspection tools, machine origins and toolsets. Ease of use thanks to the integrated touch screen.



Inspection function for accurate control of the tool status. Possibility to increase or decrease the brightness for a better visibility.

Td SIX (Tool Data SIX)

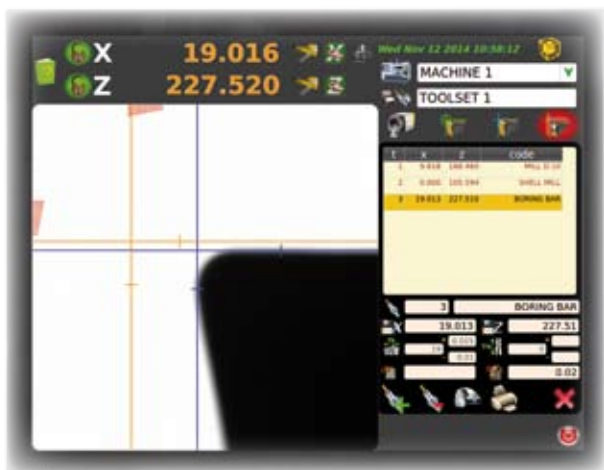

Td SIX is a new additional software function developed by Elbo Controlli, used to acquire tool's measurements, to input them into the tooling tables and create a file including tools offsets.



The data are elaborated and post-processed by the software. There are more than 50 post-processor format for the most common numerical controls available on machine tool market.

MACHINE 1 TOOLSET 1
Mon Oct 27 2014

T	Code	x	xTh	z	zTh	A	R
1	MILL D.10	9.918	10 ⁺⁰ _{-0.30}	166.46	166.5 ^{+0.05} _{-0.05}		
2	SHELL MILL	0	0	105.594	105.6	45	
3	BORING BAR	19.013	19 ^{+0.010} _{-0.01}	227.51	0		0.02

It's possible to generate and / or print a report with the theoretical values, tolerances and measurements of the selected tool table.



MACHINE 1
Mon Oct 27 2014

TOOLSET 1

T	Code	x	xTh	z	zTh	A	R
1	MILL D.10	9.918	10 ⁺⁰ _{-0.30}	166.46	166.5 ^{+0.05} _{-0.05}		
2	SHELL MILL	0	0	105.594	105.6	45	
3	BORING BAR	19.013	19 ^{+0.010} _{-0.01}	227.51	0		0.02

TECHNICAL FEAUTERS

- Measuring range: diameter max 400 mm (radius 200 mm); height max 600 mm.
- Machine structure in stainless-steel offering high mechanical resistance and long life.
- Base and column made of natural granite: linearity max error 4 µm/Mt certification with Taylor Hobson res.1 µm/Mt electronic millesimal level.
- ISO/BT/HSK/VDI etc. Interchangeable rotating spindle-holder (to be specified) max run-out error < 4 µm. Vacuum tool clamping of ISO/BT tool shanks.
- Double vault arc prismatic slideways: n°2 X axis slideways, n°1 Z axis slideway.
- Double re-circulating ball bearing slides, lubricated for life (3) (preloading slides/slideways: P/H class).
- Manual mechanical braking of the interchangeable spindle-holder rotation.
- Constant load Archimedean spiral spring (as opposed a mass counter-balance system).
- Vision-system for tool measuring and cutting inspection including:
 - C-MOS sensor - Framed image area 6,4 x 6,4 mm. ☑
 - Magnifications about 30X.
 - Telecentric lens.
 - Doublet lenses at low F/Number in order to eliminate the error of the clearness circle.
 - Episcopic illuminator with ring lens and red leds; diascopeC illuminator with red, puntiform light led.
- Machine operator interface through:
 - TFT 15" colour Touch Screen.
 - Intel Atom D.C. fanless motherboard.
 - UBUNTU LINUX operating system.
 - Data storage on solid state disk SSD.
 - X and Z axes block management with control maximum speed of translation 2mm/sec.
 - N°3 USB ports and N°1 LAN
- Standard software:
 - CNC machine origin management and adapters.
 - Tool list creation and/or single tool.
 - Td SIX (Tool Data SIX) to manage:
 - tools set and Post Processor universal generator;
 - magnetic chip code-holders (Balluff for example, hardware not included);
 - printable tool set report;
 - theoretical measurements and tolerances management.
- ELBO CONTROLLI Linear Transducers in optical glass type SLIDE 371 certified HP laser:
 - Axes resolution: X =1 µm, Z= 1 µm.
- Anti-dust cover provided for when not in use.
- Overall dimensions: Length = 1070mm, Height = 1140mm, Depth = 595 mm
- Net weight: 135 Kg

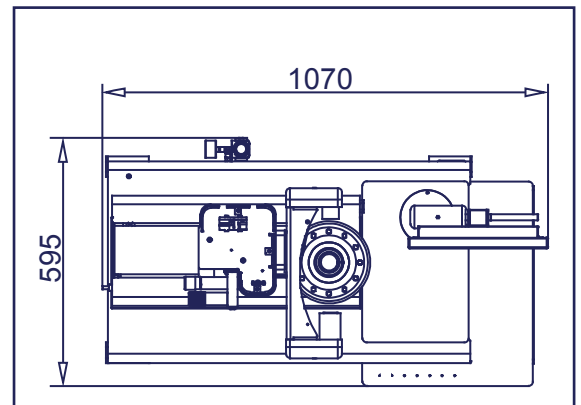
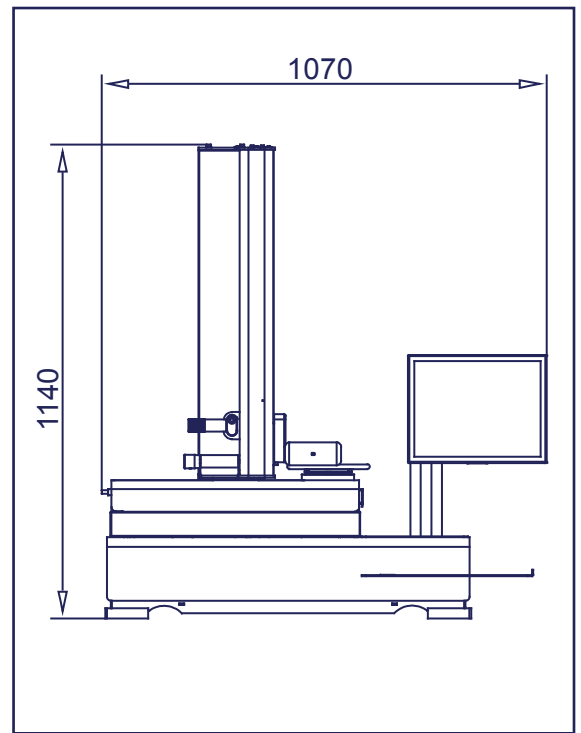

elbo controllli 

NIKKEN KOSAKUSHO EUROPE LIMITED
Precision House, Barbot Hall Industrial Estate,
Rotherham, South Yorkshire, S61 4RL

Tel: 01709 366306 www.nikken-world.com

