

 **OSAWA**  
D R I L L S   &   E N D   M I L L S

CATALOGUE 2011



## MDC - Alu mills

🇬🇧 MDC Diamond, micro grain carbide, geometry specifically designed to machine graphite and new coating MDC-Diamond with increased thickness to achieve an even longer tool life.

ALU MILLS, for Aluminium and alloy, made of micro grain carbide and HSS/Co, geometry specifically designed and polished flutes, ensure long tool life, outstanding surface finishing and accuracy even at ultra fast cutting speed.

🇮🇹 MDC Diamond, metallo duro micrograna, con geometria specifica per la lavorazione di grafite e nuovo rivestimento diamante MDC a spessore maggiorato per garantire una durata ancor più lunga.

ALU MILLS, per Alluminio e leghe, in metallo duro micrograna e HSS/Co, con geometria specifica e gole lappate, garantiscono lunga durata, finitura eccezionale e taglio preciso anche alle altissime velocità.

🇩🇪 MDC Diamond aus Hartmetall Mikrokorn, mit Spezialgeometrie entworfen für das Fresen von Graphit. Dank der neuen extrastarken MDC Diamant Beschichtung, wird eine noch längere Lebensdauer garantiert.

ALU MILLS, für Aluminium und legierungen, Fräser aus Hartmetall Mikrokorn und HSS/Co, mit Spezialgeometrie und das Reibschleifen von Rillen. Diese Fräser garantieren Lebensdauer, hervorragende Fertigungsqualität und einen genauen Schnitt auch bei Hochgeschwindigkeiten.

🇫🇷 MDC Diamond, carbure micro grain revêtu monobloc, avec géométrie spécifique pour l'usinage de la graphite et nouveau revêtement diamant MDC à grande épaisseur, pour une durée encore plus longue.

ALU MILLS, pour Aluminium et alliages, en carbure micro grain revêtu monobloc et HSS/Co, avec géométrie spécifique et goujures polies, garantissent une longue durée, une finition exceptionnelle et une coupe très précise, même à vitesse de coupe très élevée.



  
 PAGE 250

**OSAWA**  
**NORM**

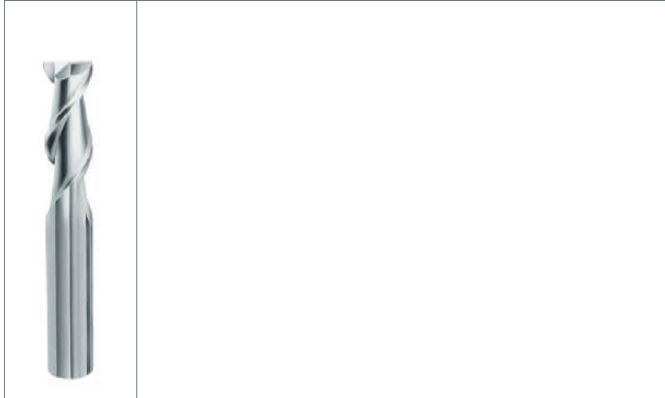
**MDCSA2**

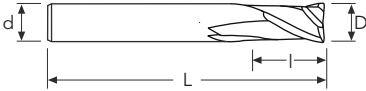

MDCSA2	
Ø mm	3~20
tol. D µ	0 / -30





Z2

MG

LAPPED

ALU



42°

D	d(h6)	l	L	Stock
mm 3	6	8	57	●
4	6	11	57	●
5	6	13	57	●
6	6	13	57	●
8	8	19	63	●
10	10	22	72	●
12	12	26	83	●
14	14	26	83	●
16	16	32	92	●
18	18	32	92	●
20	20	38	104	●

● stock standard    ○ non-standard stock    EX stock exhaustion

  
 PAGE 250

**OSAWA**  
**NORM**

**MCA212R**



**MCA212R**

Ø mm	2~12
tol. D µ	0 / -30
tol. R µ	±

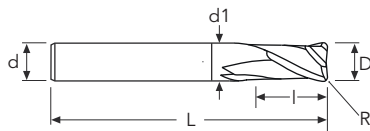

$d1 < D$



D	d(h6)	l	l1	L	Stock
mm 2 xR0.2	3	3	6	40	●
3 xR0.2	3	4	8	40	●
4 xR0.2	4	5	12	50	●
5 xR0.2	5	8	14	50	●
6 xR0.2	6	8	18	65	●
8 xR0.2	8	10	22	70	●
10 xR0.2	10	14	28	80	●
12 xR0.2	12	16	35	90	●

● stock standard   ○ non-standard stock   EX stock exhaustion

**n** **Vf**  
PAGE 251

**OSAWA**  
**NORM**

**MDCSA3**

Ø mm	~6	8~12	16~20
tol. D µ	0 / -20	0 / -25	0 / -30

**MDA310 - MDA311 - MDA312**

Ø mm	~6	8~12	16~20
tol. D µ	0 / -30	0 / -35	0 / -40

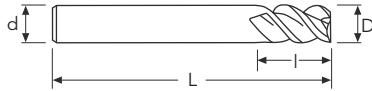

d1 < D

MG	MG	MG	MG
LAPPED	LAPPED	LAPPED	LAPPED
<b>ALU</b>	<b>ALU</b>	<b>ALU</b>	<b>ALU</b>

D	d(h6)	l	L	Stock	Stock	Stock	Stock
mm 1	4	3	50	●			
1.5	4	4.5	50	●			
2	4	6	50	●			
3	4	8	50	●			
3	6	12	75		●		
3	6	15	100			●	
4	4	11	50	●			
4	6	16	75		●		
4	6	20	100			●	
5	6	13	50	●			
5	6	20	75		●		
5	6	30	100			●	
6	6	15	50	●			
6	6	30	75		●		
8	8	20	60	●			
8	8	35	100			●	
8	8	40	150				●
10	10	25	75	●			
10	10	40	100			●	
10	10	50	150				●
12	12	30	75	●			
12	12	45	100			●	
12	12	50	150				●
16	16	40	100	●			
16	16	70	150				●
20	20	40	100	●			
20	20	80	150				●

● stock standard ○ non-standard stock EX stock exhaustion

  
 PAGE 251

**OSAWA  
NORM**

MDCAB2

Ø mm	~6	8-12
tol. D µ	0 / -20	0 / -25
tol. R µ	± 10	± 10

**NEW**

MDCAB2

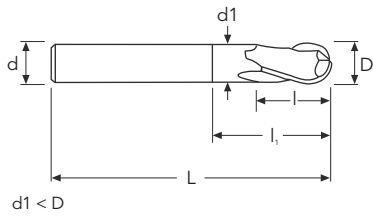

 Z2 BALL  
 MG LAPPED  
 ALU BALL NOSE  
 40°

D	d(h6)	l	l1	L	Stock
mm 1	4	2		50	●
1.5	4	3		50	●
2	4	4		50	●
3	4	6		50	●
4	4	8		50	●
5	6	10		50	●
6	6	12		50	●
8	8	16		60	●
10	10	20		75	●
12	12	24		75	●

● stock standard   ○ non-standard stock   EX stock exhaustion

  
 PAGE 252

**DIN  
844**

WSA2

Ø mm	3~6	7~10	12~18	20~25
tol.D µ	±60	±75	±90	±105

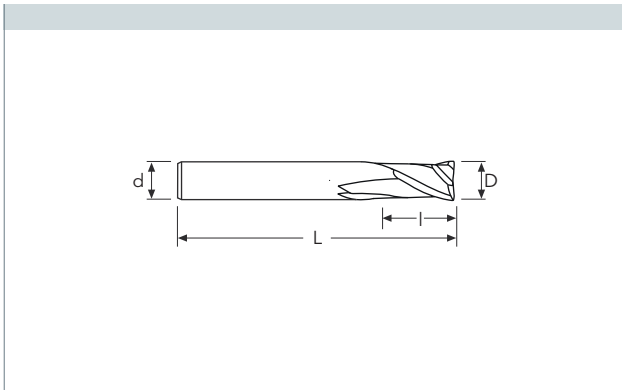
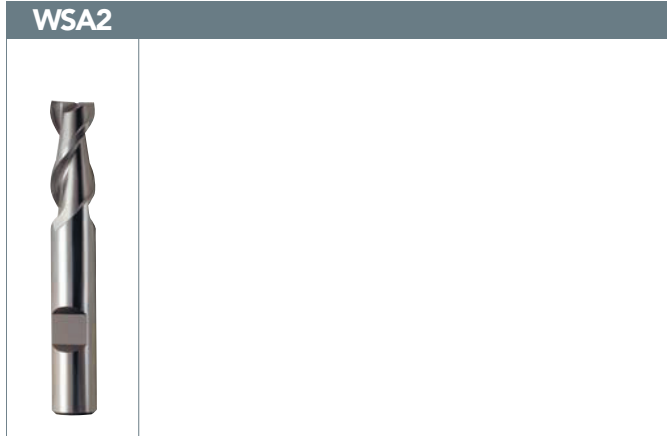

D(e8)	d(h6)	l	L	Stock
mm 2	6	7	51	●
2.5	6	8	52	●
3	6	8	52	●
4	6	11	55	●
5	6	13	57	●
6	6	13	57	●
8	10	19	69	●
10	10	22	72	●
12	12	26	83	●
14	12	26	83	●
16	16	32	92	●
18	16	32	92	●
20	20	38	104	●

● stock standard   ○ non-standard stock   EX stock exhaustion

  
 PAGE 252

**DIN**  
**844**

WSAR (js12)

Ø mm	3~6	7~10	12~18	20~25
tol.D µ	±60	±75	±90	±105

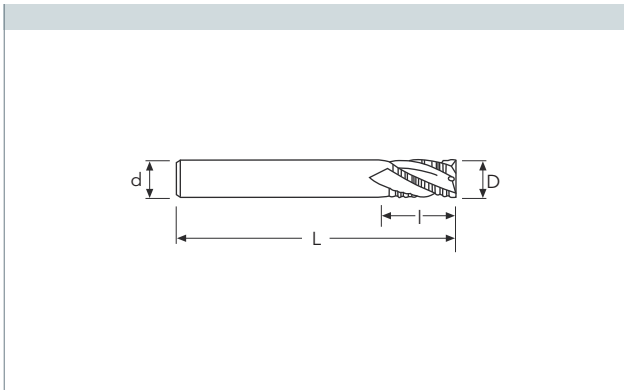
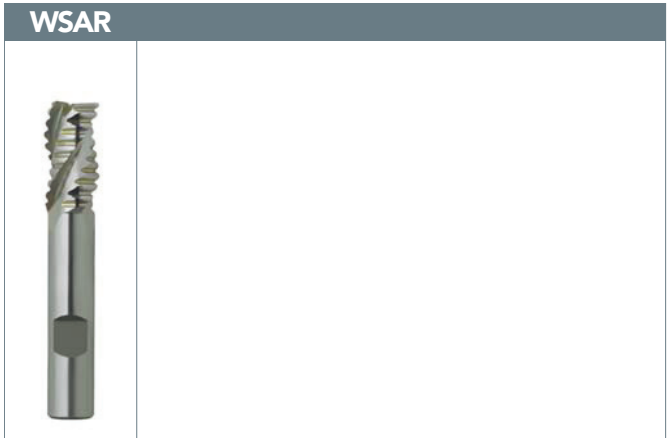

HSS/Co  
BR

ALU WR  
COARSE



D(js12)	d(h6)	l	L	Stock
mm 6	6	13	57	●
8	10	19	69	●
10	10	22	72	●
12	12	26	83	●
14	12	26	83	●
16	16	32	92	●
18	16	32	92	●
20	20	38	104	●
25	25	45	121	●

● stock standard   ○ non-standard stock   EX stock exhaustion



MDCSA2			
GROUP GRUPPO GRUPPE GROUPE	15 16		
Vc [m/min]	100~250		
HRC			
N/mm <sup>2</sup>			
Ø mm.	n	Vf	
3	10000	700	
4	10000	900	
5	10000	1000	
6	10000	1200	
8	8000	1400	
10	8000	1700	
12	8000	2100	
14	6000	1800	
16	6000	1900	
18	4000	1400	
20	4000	1600	
<b>S ap x ae</b>	0.5DxD		
<b>SM ap x ae</b>	Dx0.5*D		

\*≤Ø10 ae=0.25D

↓ Z axis : Vf = -50%

MCA212R			
GROUP GRUPPO GRUPPE GROUPE	15 16		
Vc [m/min]	130~380		
HRC			
N/mm <sup>2</sup>			
Ø mm.	n	Vf	
3	13000	900	
4	13000	1200	
5	13000	1300	
6	13000	1500	
8	10000	1800	
10	10000	2200	
12	10000	2700	
<b>S ap x ae</b>	0.5DxD		
<b>SM ap x ae</b>	Dx0.5*D		

\*≤Ø10 ae=0.25D

↓ Z axis : Vf = -50%

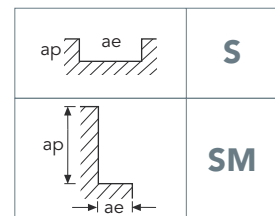

MDCSA3 - MDA310* - MDA311** - MDA312**			
GROUP GRUPPO GRUPPE GROUPE	<b>15</b> <b>16</b>		
Vc [m/min]	150~250		
HRC			
N/mm <sup>2</sup>			
Ø mm.	n	Vf	
3	21200	950	
4	16000	960	
5	12800	960	
6	10600	960	
8	8000	960	
10	6400	1150	
12	5300	1200	
16	4000	1200	
20	3200	1200	
<b>S ap x ae</b>	0.5DxD		
<b>SM ap x ae</b>	1.5Dx0.2D		

\*MDA310 n & Vf = -30%; ae = 0.1D

\*\*MDA311, MDA312 n & Vf = -50%; ap = 0.1D

↓ Z axis : Vf = -50%

MDCAB2			
GROUP GRUPPO GRUPPE GROUPE	<b>15</b> <b>16</b>		
Vc [m/min]	200~300		
HRC			
N/mm <sup>2</sup>			
Ø mm.	n	Vf	
3	26500	1300	
4	20000	1300	
5	16000	1300	
6	13300	1350	
8	10000	1400	
10	8000	1300	
12	6600	1300	
<b>C ap x p</b>	0.2Dx0.5D		

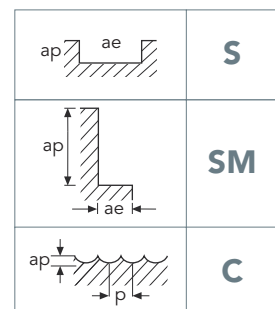

WSA2			
GROUP GRUPPO GRUPPE GROUPE	15 16		
Vc [m/min]	80~150		
HRC			
N/mm <sup>2</sup>			
Ø mm.	n	Vf	
3	8000	560	
6	7000	700	
8	6000	850	
10	5000	1200	
12	5000	1200	
14	3500	1250	
16	3500	1250	
18	2300	1300	
20	2300	1300	
S ap x ae	0.5DxD		
SM ap x ae	Dx0.5*D		

\*≤Ø10 ae=0.25D  
 ↓ Z axis : Vf = -50%

WSAR			
GROUP GRUPPO GRUPPE GROUPE	15 16		
Vc [m/min]	70~90		
HRC			
N/mm <sup>2</sup>	~500		
Ø mm.	n	Vf	
6	4500	200	
8	3100	230	
10	2500	350	
12	2000	400	
14	1800	420	
16	1600	450	
18	1400	470	
20	1200	500	
S ap x ae	DxD		
SM ap x ae	1.5Dx0.5D		

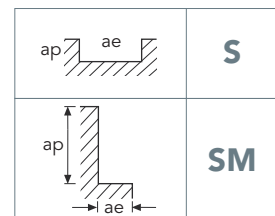

# Parameters

GROUPS / GRUPPI / GRUPPE / GROUPES	AISI	W-stoff	DIN	BS	SS
<b>1</b> <math>< 450 \text{ N/mm}^2</math> LOW CARBON AND FREE CUTTING STEEL ACCIAI A BASSO TENORE DI CARBONIO ED AUTOMATICI KOHLENSTOFFARME STÄHLE ACIERS BAS CARBONE ET POUR DÉCOLLETAGE	A570-36	1.0038	RSt 37-2	4360 40 C	1311
	A36	1.0044	St 44-2	4360 43 A	1411
	A573-81 65	1.0116	St 37-3	4360 40 B	1312
	1006	1.0201	St 36	-	1160
	A515-65	1.0345	H I	1501 161	1330
	1015	1.0401	C 15	080 M 15	1350
	1020	1.0402	C22	050 A 20	1450
	-	1.0425	H II	-	1432
	1213	1.0715	9 SMn 28	230 M 07	1912
	(12L13)	1.0718	9 SMnPb 28	-	1914
	-	1.0723	15 S 20	210 A 15	1922
	1140	1.0726	35 S 20	212 M 36	1957
	1146	1.0727	45 S 20	212 M 44	1973
	1215	1.0736	9 SMn 36	240 M 07	-
	-	1.0765	-	-	-
	1010	1.1121	Ck 10	045 M 10	1265
	-	1.1121	St 37-1	4360 40 A	1300
	1022	1.1133	GS-20Mn 5	120 M 19	1410
	1015	1.1141	Ck 15	080 M 15	1370
	1025	1.1158	Ck 25	070 M 26	1450
1018	-	-	-	-	
<b>2</b> <math>450-700 \text{ N/mm}^2</math> MEDIUM CARBON STEEL ACCIAI A MEDIO TENORE DI CARBONIO MITTELGEKÖHLTE FLUSSSTÄHLE ACIERS MOYEN CARBONE	A662 C	1.0436	ASt 45	1501 224	2103
	1035	1.0501	C 35	060 A 35	1550
	1035	1.0501	C 35	080 M 36	1550
	1045	1.0503	C 45	080 M 46	1650
	1040	1.0511	C 40	080 M 40	-
	1055	1.0535	C 55	070 M 55	1655
	-	1.0570	St 52-3	4360 50 B	2132
	A738	1.0577	ASt 52	1501 224	2107
	1039	1.1157	40Mn4	150 M 36	-
	1035	1.1181	Ck 35	060 A 35	1572
	1035	1.1183	Cf 35	080 M 36	1572
	1045	1.1191	Ck 45	808 M 46	1672
	1055	1.1203	Ck55	070 M 55	-
	1050	1.1213	Cf 53	060 A 52	1674
	1045	1.1730	C45W	En 43 B	1672
A572-60	1.8900	StE 380	4360 55 E	2145	
-	1.8905	StE 460	HP 6	-	
<b>3</b> <math>550-850 \text{ N/mm}^2</math> HIGH CARBON STEEL ACCIAI AD ELEVATO TENORE DI CARBONIO KOHLENSTOFFREICHE STÄHLE ACIERS HAUT CARBONE	1060	1.0601	C60	060 A 62	-
	1064	1.1221	Ck 60	060 A 62	1678
	1070	1.1231	Ck 67	070 A 72	1770
	1080	1.1248	Ck 75	060 A 78	1774
	1095	1.1274	Ck 101	060 A 96	1870
<b>4</b> <math>600-900 \text{ N/mm}^2</math> LOW ALLOY STEEL ACCIAI DEBOLMENTE LEGATI NIEDRIGLEGIERTE STÄHLE ACIERS FAIBLEMENT ALLIÉS	9255	1.0904	55 Si 7	250 A 53	2090
	1335	1.1167	36 Mn 5	150 M 36	2120
	1330	1.1170	28 Mn 6	150 M 28	-
	P4	1.2341	X6 CrMo 4	-	-
	52100	1.3505	100 Cr 6	534 A 99	2258
	A204A	1.5415	15 Mo 3	1501 240	2912
	8620	1.6523	21 NiCrMo 2	805 M 20	2506
	8740	1.6546	40NiCrMo22	311-Type 7	-
	-	1.6587	17CrNiMo6	820 A 16	-
	5132	1.7033	34 Cr 4	530 A 32	-
	5140	1.7035	41 Cr 4	530 A 40	-
	5140	1.7035	41 Cr 4	530 A 40	-
	5140	1.7045	42 Cr 4	530 A 40	2245
	5115	1.7131	16 MnCr 5	(527 M 20)	2511
	5155	1.7176	55 Cr 3	527 A 60	2253
	4130	1.7218	25 CrMo 4	1717CDS 110	2225
	4135 (4137)	1.7220	35 CrMo 4	708 A 37	2234
	4142	1.7223	41 CrMo 4	708 M 40	2244
	4140	1.7225	42 CrMo 4	708 M 40	2244
	4137	1.7225	42 CrMo 4	708 M 40	2244
	A387 12-2	1.7337	16 CrMo 4 4	1501 620	2216
	-	1.7361	32CrMo12	722 M 24	2240
	A182 F-22	1.7380	10 CrMo9 10	1501 622	2218
	6150	1.8159	50 CrV 4	735 A 50	2230
	-	1.8515	31 CrMo 12	722 M 24	2240
	-	-	-	-	-

AFNOR	U.N.E. / I.H.A.	JIS	UNI	EN	ISO	TRADE MARK
E 24-2 Ne	-	SS 34	Fe 360B FN	-	-	-
NFA 35-501 E 28	-	-	-	-	-	-
E 24-U	-	-	Fe37-3	-	-	-
Fd 5	-	-	-	-	-	-
A 37 CP	F.1110	SGV 410	-	-	-	-
CC 12	F.111	S 15 C	080 M 15	-	-	-
CC20	F.112	-	C20C21	-	-	-
A 42 CP	A42 RCI	SGV 410	Fe 410 1KW	-	-	-
S 250	11SMn28	SUM 22	CF9SMn28	-	-	AVP
S 250 Pb	11SMnPb28	SUM 22 L	CF9SMnPb28	-	-	-
-	F.210.F	SUM 32	-	-	-	-
35 MF 6	F.210.G	-	-	-	-	-
45 MF 4	-	-	-	-	-	-
S 300	12 SMn 35	SUM 25	CF 9 SMn 36	-	-	AVZ
-	-	-	36SMnPb14	-	-	PR 80
XC 10	F.1510	S 10 C	C10	-	-	-
-	-	S 10 C	-	-	-	-
20 M 5	F.1515	SMnC 420	G22Mn3	-	-	-
XC 18	F.1511	S 15 Ck	080 M 15	-	-	-
XC 25	F.1120	S 25 C	C25	-	-	-
-	-	SS400	Fe 360 B	-	-	-
A 48 FP	-	-	-	-	-	-
CC 35	F.113	S 35 C	C35	-	-	-
CC 35	F.113	S 35 C	C35	-	-	-
CC45	F.114	S 45 C	C45	-	-	-
AF 60 C 40	F.114.A	-	C40	-	-	-
AF 70 C 55	F.115	S 55 C	C55	-	-	-
E 36-3	-	SM 490 A, B, C	Fe 510	-	-	-
A 52 FP	-	-	-	-	-	-
35 M 5	-	-	-	-	-	-
XC 38	F.1130	S 35 C	C35	-	-	-
XC 38 TS	-	S 35 C	C36	-	-	-
XC 45	F.1140	S 45 C	C45	-	-	-
XC 55	F.1203	S55 C	C50	-	-	-
XC 48 TS	-	S 50 C	C53	-	-	-
Y342	F.1140	-	-	-	-	-
-	-	-	FeE390KG	-	-	-
-	-	-	-	-	-	-
CC55	-	-	C60	-	-	-
XC 65	F.1150	S 58 C	C60	-	-	-
XC 68	F.5103	-	C70	-	-	-
XC 75	F.5107	-	-	-	-	-
XC 100	F.5117	SUP 4	-	-	-	-
55 S 7	56Si7	-	55Si8	-	-	-
40 M 5	36Mn5	SMn 438(H)	-	-	-	-
20 M 5	-	SCMn1	C28MN	-	-	-
-	-	-	-	-	-	-
100 C 6	F.131	SUJ 2	100Cr6	-	-	-
15 D 3	16 Mo3	STBA 12	16Mo3 KW	-	-	-
20 NCD 2	F.1522	SNCM 220(H)	20NiCrMo2	-	-	-
40 NCD 2	F.129	SNCM 240	40NiCrMo2(KB)	-	-	-
18 NCD 6	14NiCrMo13	-	-	-	-	-
32 C 4	35Cr4	SCr430(H)	34Cr4(KB)	-	-	-
42 C 2	42 Cr 4	SCr 440 (H)	40Cr4	-	-	-
42 C 2	42 Cr 4	SCr 440 (H)	41Cr4 KB	-	-	-
42 C 4 TS	F.1207	SCr 440	-	-	-	-
16 MC 5	F.1516	-	16MnCr5	-	-	-
55 C 3	-	SUP 9(A)	55Cr3	-	-	-
25 CD 4	F.1251/55Cr3	SCM 420 / SCM430	25CrMo4(KB)	-	-	-
35 CD 4	34 CrMo 4	SCM 432	34CrMo4KB	-	-	-
42 CD 4 TS	42 CrMo 4	SCM 440	41 CrMo 4	-	-	-
40 CD 4	F.1252	SCM 440	40CrMo4	-	-	-
42 CD 4	F.1252	SCM 440	42CrMo4	-	-	-
15 CD 4.5	-	-	12CrMo910	-	-	-
30 CD 12	F.124.A	-	30CrMo12	-	-	-
12 CD 9, 10	F.155 / TU.H	-	12CrMo9 10	-	-	-
50 CV 4	F.143	SUP 10	50CrV4	-	-	-
30 CD 12	F.1712	-	30CrMo12	-	-	-
-	-	-	-	-	-	Weldox 500

GROUPS / GRUPPI / GRUPPE / GROUPES	AISI	W-stoff	DIN	BS	SS
<b>5</b> 700-1000 N/mm <sup>2</sup> ALLOY STEEL ACCIAI LEGATI LEGIERTE STÄHLE ACIERS ALLIÉS	W1	1.1545	C105W1	BW1A	1880
	L3	1.2067	100Cr6	BL 3	(2140)
	L2	1.2210	115 CrV 3	-	-
	P20 + S	1.2312	40 CrMnMoS 8 6	-	-
	-	1.2419	105WCr6	-	2140
	O1	1.2510	100 MnCrW 4	BO1	-
	S1	1.2542	45 WCrV 7	BS1	2710
	4340	1.6582	34 CrNiMo 6	817 M 40	2541
	5120	1.7147	20 MnCr 5	-	-
	-	-	-	-	-
<b>6</b> 900-1200 N/mm <sup>2</sup> TOOL AND HIGH ALLOY STEEL ACCIAI DA UTENSILI E ALTO LEGATI WERKZEUG- UND HOCHLEGIERTE STÄHLE ACIERS POUR OUTILS ET FORTEMENT ALLIÉS	D3	1.2080	X210 Cr 12	BD3	2710
	P20	1.2311	40 CrMnMo 7	-	-
	H13	1.2344	X40CrMoV 5 1	BH13	2242
	A2	1.2363	X100 CrMoV 5 1	BA2	2260
	D2	1.2379	X155 CrMoV 12 1	BD2	2310
	D4 (D6)	1.2436	X210 CrW 12	BD6	2312
	H21	1.2581	X30WCrV9 3	BH21	-
	L6	1.2713	55NiCrMoV 6	-	-
	M 35	1.3243	S6/5/2/5	BM 35	2723
	M 2	1.3343	S6/5/2	BM2	2722
	M 7	1.3348	S2/9/2	-	2782
	HW 3	1.4718	X45CrSi 9 3	401 S 45	-
	-	1.7321	20 MoCr 4	-	2625
<b>7</b> 1200-1500 N/mm <sup>2</sup> (35-45HRC) HIGH TENSILE STRENGTH STEEL ACCIAI AD ELEVATA RESISTENZA HOCHFESTE STÄHLE ACIERS HAUTE RÉSIDANCE	A128 (A)	1.3401	G-X120 Mn 12	BW10	2183
<b>8</b> 45-63HRC HARDENED STEEL ACCIAI TEMPRATI GEHÄRTETE STÄHLE ACIERS TREMPÉS	-	-	-	-	-
<b>9</b> MARTENSITIC AND FERRITIC STAINLESS STEEL ACCIAI INOSSIDABILI MARTENSITICI E FERRITICI MARTENSITISCHE UND FERRITISCHE ROSTFREIE STÄHLE ACIERS INOXYDABLES MARTENSITIQUE ET FERRITIQUE	420 C	1.4034	X43Cr16	-	-
	440 B/1	1.4112	X90 Cr Mo V18	-	-
	-	1.2083	X42 Cr 13	-	2314
	403	1.4000	X6Cr13	403 S 17	2301
	(410S)	1.4001	X7 Cr 14	(403 S17)	2301
	405	1.4002	X6 CrAl 13	405 S 17	-
	416	1.4005	X12 CrS 13	416 S 21	2380
	410	1.4006	X 10 Cr 13	410 S21	2302
	430	1.4016	X6 Cr 17	430 S 17	2320
	420	1.4021	X20 Cr 13	420 S 37	2303
	420F	1.4028	X30 Cr 13	420 S 45	(2304)
	(420)	1.4031	X39Cr13	420 S 45	(2304)
	431	1.4057	X20 CrNi 17 2	431 S 29	2321
	430F	1.4104	X12 CrMoS 17	-	2383
	434	1.4113	X6 CrMo 17	434 S 17	2325
	430Ti	1.4510	X6 CrTi 17	-	-
	409	1.4512	X5 CrTi 12	409 S 17	-
<b>10</b> AUSTENITIC STAINLESS STEEL (V2A) ACCIAI INOSSIDABILI AUSTENITICI (V2A) AUSTENITISCHE ROSTFREIE STÄHLE (V2A) ACIERS INOXYDABLES AUSTENITIQUE (V2A)	304	1.4301	X5 CrNi 18 9	304 S 15	2332
	305	1.4303	X5 CrNi 18 12	305 S 19	-
	303	1.4305	X12 CrNiS 18 8	303 S 21	2346
	304L	1.4306	X2 CrNiS 18 9	304 S 12	2352
	301	1.4310	X12 CrNi 17 7	-	2331
	304	1.4350	X5 CrNi 18 9	304 S 31	2332
	304	1.4350	X5 CrNi 18 9	304 S 31	2333
<b>11</b> AUSTENITIC STAINLESS STEEL (V4A) ACCIAI INOSSIDABILI AUSTENITICI (V4A) AUSTENITISCHE ROSTFREIE STÄHLE (V4A) ACIERS INOXYDABLES AUSTENITIQUE (V4A)	304LN	1.4311	X2 CrNiN 18 10	304 S 62	2371
	316	1.4401	X5 CrNiMo 18 10	316 S 16	2347
	316L	1.4404	-	316 S 12/13/14/22/24	2348
	316LN	1.4429	X2 CrNiMoN 18 13	-	2375
	316L	1.4435	X2 CrNiMo 18 12	316 S 12/13/14/22/24	2353
	316	1.4436	-	316 S 33	2343
	317L	1.4438	X2 CrNiMo 18 16	317 S 12	2367
	329	1.4460	X3 CrNiMoN 27 5 2	-	2324
	321	1.4541	X10 CrNiTi 18 9	321 S 12	2337
	347	1.4550	X10 CrNiNb 18 9	347 S 17	2338
	316Ti	1.4571	X10 CrNiMoTi 18 10	320 S 17	2350
	309	1.4828	X15 CrNiSi 20 12	309 S 24	-
	330	1.4864	X12 NiCrSi 36 16	-	-

AFNOR	U.N.E. / I.H.A.	JIS	UNI	EN	ISO	TRADE MARK
Y 105	F.5118	SK 3	C100 KU	-	-	-
Y 100 C 6	F.520 L	-	-	-	-	-
-	-	-	-	-	-	-
40 CMD 8 +S	X210CrW12	-	-	-	-	Holdax
105W C 13	F.5233	SKS 31	107WCr5KU	-	-	-
90MnWCrV5	F.5220	(SK53)	95MnWCr5KU	-	-	-
55W20	F.5241	-	45WCrV8KU	-	-	-
35 NCD 6	F.1280	SNCM 447	35NiCrMo6KB	-	-	-
20 MC 5	-	-	-	-	-	-
-	-	-	-	-	-	Weldox 700
Z200 C 12	F.5212	SKD 1	X210Cr13KU	-	-	K 100
40 CMD 8	F.5263	-	-	-	-	-
Z 40 CDV 5	F.5318	SKD 61	X40CrMoV511KU	-	-	-
Z 100 CDV 5	F.5227	SKD 12	X100CrMoV51KU	-	-	-
Z 160 CDV 12	F.520.A	SKD11	X155CrVMo121KU	-	-	K 110
Z 200 CD 12	F.5213	SKD 2	X215CrW121KU	-	-	-
Z 30 WCV 9	F.526	SKD5	X30WCrV 9 3 KU	-	-	-
55 NCDV 7	F.520.S	SKT4	-	-	-	-
6-5-2-5	F.5613	SKH 55	HS6-5-5	-	-	-
Z 85 WDCV	F.5603	SKH 51	HS6-5-2-2	-	-	-
2 9 2	-	-	HS2-9-2	-	-	-
Z 45 CS 9	F.3220	SUH1	X45CrSi8	-	-	-
-	F.1523	-	30CrMo4	-	-	-
Z 120 M 12	F.8251	SCMnH 1	GX120Mn12	-	-	-
-	-	-	-	-	-	-
-	-	-	-	-	-	WRB WRA
Z 40 C 14	F.5263	SUS 420 J1	-	-	-	-
Z 6 C 13	F.3110	SUS 403	X6Cr13	-	-	-
Z 8 C 13	F.3110	SUS 410 S	X6Cr13	-	-	-
Z 8 CA 12	F.3111	SUS 405	X6 CrAl 13	-	-	-
Z 11 CF 13	F.3411	SUS 416	X12CrS13	-	-	-
Z 10 C 14	F.3401	SUS 410	X12Cr13	-	-	-
Z 8 C 17	F.3113	SUS 430	X8Cr17	-	-	-
Z 20 C 13	F.3402	SUS 420 J1	X20Cr13	-	-	-
Z 30 C 13	F.3403	SUS 420 J2	X30Cr13	-	-	-
Z 40 C 14	F.3404	(SUS 420 J1)	-	-	-	-
Z 15 CNi 16.02	F.3427	SUS 431	X16CrNi16	-	-	-
Z 10 CF 17	F.3117	SUS 430 F	X10CrS17	-	-	-
Z 8 CD 17.01	-	SUS 434	X8CrMo17	-	-	-
Z 4 CT 17	-	SUS 430 LX	X6CrTi17	-	-	-
Z 6 CT 12	-	SUH 409	X6CrTi12	-	-	-
Z 6 CN 18.09	F.3551	SUS 304	X5CrNi18 10	-	-	-
Z 8 CN 18.12	-	SUS 305	X8CrNi19 10	-	-	-
Z 10 CNF 18.09	F.3508	SUS 303	X10CrNiS 18 09	-	-	-
Z 2 CN 18.10	F.3503	SUS 304L	X2CrNi18 11	-	-	-
Z 12 CN 17.07	F.3517	SUS 301	X12CrNi17 07	-	-	-
Z 6 CN 18.09	F.3551	SUS 304	X5CrNi18 10	-	-	-
Z 6 CN 18.09	F.3551	SUS 304	X5CrNi18 10	-	-	-
Z 2 CN 18.10	-	SUS 304 LN	-	-	-	-
Z 6 CND 17.11	F.3543	SUS 316	X5CrNiMo17 12	-	-	-
Z 2 CND 17.13	-	SUS316L	X2CrNiMo17 12	-	-	-
Z 2 CND 17.13	-	SUS 316 LN	-	-	-	-
Z 2 CND 17.13	-	SUS316L	X2CrNiMo17 12	-	-	-
Z 6 CND18-12-03	-	-	X8CrNiMo 17 13	-	-	-
Z 2 CND 19.15	-	SUS 317 L	X2CrNiMo18 16	-	-	-
Z5 CND 27.05.Az	F.3309	SUS 329 J1	-	-	-	-
Z 6 CND 18.10	F.3553	SUS 321	X6CrNiTi18 11	-	-	-
Z 6 CNNb 18.10	F.3552	SUS 347	X6CrNiNb18 11	-	-	-
Z 6 CNDT 17.12	F.3535	-	X6CrNiMoTi 17 12	-	-	-
Z 15 CNS 20.12	-	SUH 309	X16 CrNi 24 14	-	-	-
Z 12 NCS 35.16	-	SUH 330	-	-	-	-



GROUPS / GRUPPI / GRUPPE / GROUPES	AISI	W-stoff	DIN	BS	SS
<b>12</b> DUPLEX	S32750	1.4410	X 2 CrNiMoN 25 7 4	-	2328
	S31500	1.4417	X 2 CrNiMoSi 19 5	-	2376
	S31803	1.4462	X 2 CrNiMoN 22 5 3	-	2377
	S32760	1.4501	X 3 CrNiMoN 25 7	-	-
	630	1.4542	X5CrNiCNb16-4	-	-
	A564/630	-	-	-	-
<b>13</b> GREY CAST IRON GHISA GRIGIA GRAUGUSS FONTE GRISE	A48-20B	0.6010	GG-10	Grade 100	0110-00
	A48-25B	0.6015	GG-15	Grade 150	0115-00
	A48-30B	0.6020	GG-20	Grade 200	0120-00
	A48-40B	0.6025	GG-25	Grade 250	0125-00
	A48-45B	0.6030	GG-30	Grade 300	0130-00
	A48-50B	0.6035	GG-35	Grade 350	0135-00
	A48-60B	0.6040	GG-40	Grade 400	0140-00
	32510	-	GTS-35	B340/12	0815-00
	A220-40010	0.8145	GTS-45	P440/7	0852-00
	A220-50005	0.8155	GTS-55-04	P510/4	0854-00
	A220-70003	0.8165	GTS-65-02	P570/3	0856-00
	A220-70003	-	GTS-65	P570/3	0858
A220-80002	0.8170	GTS-70-02	P690/2	0862-00	
<b>14</b> NODULAR CAST IRON GHISA SFEROIDALE SPHÄROGUSS FONTE NODULAIRE	-	0.7033	GGG-35.3	350/22L40	0717-15
	60/40/18	0.7040	GGG-40	420/12	0717-02
	(60/40/18)	0.7043	GGG-40.3	370/17	0717-12
	65/45/12	0.7050	GGG-50	500/7	0727-02
	80/55/06	0.7060	GGG-60	600/3	0727-03
	100/70/03	0.7070	GGG-70	700/2	0737-01
	120/90/02	0.7080	GGG-80	800/2	-
<b>15</b> WROUGHT (ROLLED) ALUMINIUM ALLUMINIO LAMINATO GEWALZTES ALUMINIUM ALUMINIUM LAMINÉ	1200	3.0205	Al 99	1C	4010
	1050	3.0255	Al 99,5	1B	4007
	1350	3.0257	E-Al	E1E	-
	1070	3.0275	Al 99,7	-	-
	1080	3.0285	Al 99,8	1A	-
	1099	3.0385	AL99,98R	1	-
	3105	3.0505	AlMn0,5Mg0,5	N31	-
	3103	3.0515	AlMn1	N3	4054
	3003	3.0517	AlMn	N3	-
	3005	3.0525	AlMn1Mg0,5	-	-
	3004	3.0526	AlMn1Mg1	-	-
	6012	3.0615	AlMgSiPb	-	-
	2014	3.1255	AlCuSiMn	H15	4338
	2117	3.1305	AlCuMg0,5	L86	-
	2017	3.1325	AlCuMg 1	(H14)	-
	2024	3.1355	AlCuMg 2	DTD5090	-
	2030	3.1645	AlCuMgPb	-	4335
	2011	3.1655	AlCuBiPb	FC1	4355
	6082	3.2315	AlMgSi 1	H30	4212
	6060	3.3206	AlMgSi0,5	H9	4103/4104
	6005	3.3210	AlMgSi0,7	-	-
	6061	3.3211	AlMg1SiCu	H20	-
	5005	3.3315	AlMg1	N41	4106
	5050	3.3316	AlMg1,5	-	-
	5052	3.3523	AlMg2,5	-	4120
	5251	3.3525	AlMg2Mn0,3	N4	-
	5154	3.3535	AlMg3	N5/N56	-
	5454	3.3537	AlMg2,7Mn	N51	-
	5086	3.3545	AlMg4Mn	-	-
	5083	3.3547	AlMg4,5Mn	N8	4140
	5056	3.3555	AlMg5	N6	-
	7020	3.4335	AlZn4,5Mg1	H17	4425
7075	3.4365	AlZnMgCu1,5	2L95	-	
3304	-	AlMgMn	-	-	
7010	-	AlZn6MgCu	DTD5130	-	
<b>16</b> DIE-CAST ALUMINIUM (SI<12%) ALLUMINIO PRESSOFUSO (SI<12%) AL-GUSSLEGIERUNGEN (SI<12%) ALUMINIUM MOULÉ SOUS PRESSION (SI<12%)	A356	3.2371	G-AlSi7Mg	LM25	4244
	-	3.2373	G-AlSi9Mg	-	-
	A360	3.2381	G-AlSi10Mg	LM9	4253
	A413.2	3.2581	G-AlSi12	LM6	4261
	A413.0	3.2582	GD-AlSi12	-	4247
	A413.1	3.2583	G-AlSi12(Cu)	LM20	4260
	-	3.3561	G-AlMg5	LM5	4252
	-	3.5101	G-MgZn4SE1Zr1	MAG5	-
	-	3.5103	MgSE3Zn2Zr1	MAG6	-
	-	3.5106	G-MgAg3SE2Zr1	MAG 12	-

AFNOR	U.N.E. / I.H.A.	JIS	UNI	EN	ISO	TRADE MARK
Z3 CND 25.06 Az	-	-	-	-	-	-
Z2 CND 18.05.03	-	-	-	-	-	-
Z 3 CND 22.05 (Az)	-	-	-	-	-	-
Z 3 CND 25.06 Az	-	-	-	-	-	ZERON 100
-	-	-	-	-	-	-
-	-	-	-	-	-	17/4 PH
-	-	FC 100	G 10	-	-	-
Ft 15 D	FG 15	FC 150	G 15	-	-	-
Ft 20 D	FG 20	FC 200	G 20	-	-	-
Ft 25 D	FG 25	FC 250	G 25	-	-	-
Ft 30 D	FG 30	FC 300	G 30	-	-	-
Ft 35 D	FG 35	FC 350	G 35	-	-	-
Ft 40 D	-	FC 40	-	-	-	-
MN 35-10	-	FCMW 330	-	-	-	-
MN 450	-	FCMP 440/490	GMN 45	-	-	-
MP 50-5	-	FCMP 490	GMN 55	-	-	-
MN 650-3	-	FCMP 590	GMN 65	-	-	-
MN 60-3	-	FCMP 540	-	-	-	-
MN 700-2	-	FCMP 690	GMN 70	-	-	-
FGS 370/17	-	-	-	-	-	-
FGS 400/12	FGE 38-17	FCD 400	GS 400-12	-	-	-
FGS 370/17	-	-	GSO 42-12	-	-	-
FGS 500/7	FGE 50-7	FCD 500	GS 500-7	-	-	-
FGS 600/3	FGE 60-2	FCD 600	GS 600-3	-	-	-
FGS 700/2	FGS 70-2	FCD 700	GS 700-2	-	-	-
FGS 800/2	-	-	GS-800/2	-	-	-
A4	L-3001	A1x3	9001/1	-	-	-
A5	L-3051	A1x1	9001/2	-	-	-
-	-	-	-	-	-	-
A7	-	-	-	-	-	-
A8	-	-	-	-	-	-
A99	-	-	-	-	-	-
-	-	-	-	-	-	-
-	L-3811	-	9003/3	-	-	-
AM1	L-3810	A2x3	9003/1	-	-	Aluman 100
AMG0,5	-	-	9003/4	-	-	-
AM1G	L-3820	-	9003/2	-	-	-
ASGPB	-	-	-	-	-	-
AU4SG	L-3130	A3x1	9002/3	-	-	Avional 660
AU2G	-	-	9002/1	-	-	Avional 050
AU4G	L-3120	A3x2	9002/2	-	-	Avional 100
AU4G1	L-3140	A3x4	9002/4	-	-	Avional 150
AU4Pb	L-3121	-	9002/8	-	-	-
AU5PbBi	L-3192	-	9002/5	-	-	Recidal 11
ASGM 0,7	L-3451	-	9006/4	-	-	Anticorodal 100
AGS	L-3441	A2x5	9006/1	-	-	Anticorodal 063
ASG0,5	L-3454	A6NO1	9006/6	-	-	-
AGSUC	L-3420	A2x4	9006/2	-	-	Anticorodal 061
AG0,6	L-3350	A2x8	9005/1	-	-	Peraluman 080
-	-	-	9005/7	-	-	Peraluman 150
AG2,5C	L-3360	A2x1	9005/2	-	-	Peraluman 250
AG2M	L-3361	-	-	-	-	-
AG3	-	-	9005/8	-	-	Peraluman 350
AG2,5MC	L-3391	A2x9	9005/3	-	-	-
AG4MC	L-3322	-	9005/4	-	-	-
AG4,5MC	L-3321	A2x7	9005/5	-	-	Peraluman 440
A-G5	-	-	-	-	-	Peraluman 500
AZ5G	L-3741	-	9007/1	-	-	-
AZ5GU	L-3710	A34x6	9007/2	-	-	Ergal 55
AM1G	-	-	-	-	-	-
-	-	-	9007/4	-	-	-
A-S7G	-	AC4C	-	42000	AlSi7Mg	-
-	-	-	-	-	-	-
A-S10G	-	-	-	43100	Al Si 10 Mg	-
A-S12U	-	AC3A	-	44100	Al Si 12	-
-	-	-	-	-	-	-
A-S12	-	-	-	47000	Al Si 12 (Cu)	-
A-SU12	-	AC4A	-	51300	ALMg 6	-
G-Z4TR	-	-	-	-	-	-
G-TR3Z2	-	-	-	-	-	-
G-Ag22,5	-	-	-	-	-	-

GROUPS / GRUPPI / GRUPPE / GROUPES	AISI	W-stoff	DIN	BS	SS
<b>16</b> DIE-CAST ALUMINIUM (SI<12%) ALLUMINIO PRESSOFUSO (SI<12%) AL-GUSSLEGIERUNGEN (SI<12%) ALUMINIUM MOULÉ SOUS PRESSION (SI<12%)	-	3.5812	G-MgAl8Zn1	MAG1	-
	-	3.5912	G-MgAl9Zn1	MAG7	-
	355.1	-	G-AISi5	LM16	-
	A380	-	G-AISi8Cu3	LM24	4250
	319	-	G-AISi6Cu4	LM21	-
	319.2	-	G-AISi6Cu4	LM22	-
<b>17</b> COPPER RAME KUPFER CUIVRE	C10200	2.0040	OF Cu	C103	-
	C11000	2.0060	E-Cu57	C101	-
	-	2.0065	E-Cu58	-	-
	C10300	2.0070	SE Cu	-	-
	C12200	2.0090	SF Cu	C106	-
	C12500	-	Cu-FRTP	C104	-
	C70320	2.0857	-	-	-
	C14200	2.1202	SB Cu	C107	-
	-	2.1356	Cu Mn 3	-	-
	-	2.1522	Cu Si2 Mn	-	-
	C16200	-	-	C108	-
	C18200	-	-	CC101	-
	C191010	-	-	-	-
	C70250	-	-	CC102	-
	C17200	-	-	CB101	-
	C17300	-	-	-	-
	C17510	-	-	-	-
	C17500	-	-	C112	-
	C15000	-	-	-	-
	C65100	-	-	-	-
C65500	-	-	CS101	-	
C14500	-	-	C109	-	
C14700	-	-	C111	-	
C18700	-	-	-	-	
<b>18</b> BRASS OTTONE MESSING LAITON	C21000	2.0220	CuZn5	CZ125	-
	C22000	2.0230	CuZn10	Cz101	-
	C23000	2.0240	CuZn15	CZ102	-
	C24000	2.0250	CuZn20	CZ103	-
	C25600	-	CuZn28	-	-
	C26000	2.0265	CuZn30	CZ106	-
	C26800	2.0280	CuZn33	-	-
	C27200	-	CuZn36	-	-
	C27200	2.0321	CuZn37	CZ108	-
	C27000	2.0335	CuZn36	CZ107	-
C28000	2.0360	CuZn40	CZ109	-	
<b>19</b> DIE-CAST BRASS OTTONE DA FUSIONE GUSSMESSING LAITON MOULÉ SOUS PRESSION	C33500	-	CuZn37Pb0.5	-	-
	C34000	-	CuZn35Pb1	CZ118	-
	C34500	2.0331	CuZn36Pb1,5	CZ119	-
	C34000	2.0331	CuZn36Pb1,5	CZ119	-
	C35300	2.0371	CuZn38Pb1,5	CZ128	-
	C36500	2.0372	CuZn39Pb0,5	CZ123	-
	C36000	2.0375	CuZn36Pb3	CZ124	-
	C37700	2.0380	CuZn39Pb2	CZ 131 / (CZ128)	-
	C38500	2.0401	CuZn39Pb3	CZ121	-
	C38000	2.0402	CuZn40Pb2	CZ122	-
	-	2.0410	CuZn44Pb2	CZ130	-
	C68700	2.0460	CuZn20Al2	CZ110	-
	C44300	2.0470	CuZn28Sn1	CZ111	-
	-	2.0530	CuZn38Sn1	-	-
	-	2.0550	CuZn40Al2	-	-
	-	2.0561	CuZn40Al1	-	-
-	2.0572	CuZn40Mn2	CZ136	-	
C61400	2.0932	CuAl8Fe3	-	-	
C63000	2.0966	CuAl10Ni5Fe4	CA104	-	
<b>20</b> BRONZE BRONZO BRONZE BRONZE	C50700	2.1010	CuSn2	-	-
	C51100	2.1016	CuSn4	PB101	-
	C51000	-	CuSn5	PB102	-
	C51900	2.1020	CuSn6	PB103	-
	C52100	2.1030	CuSn8	PB104	-
	-	-	CuSn10	-	-
	-	-	CUSn11	-	-
<b>21</b> AMPCO	-	-	-	-	-
	-	-	-	-	-
	-	-	-	-	-

AFNOR	U.N.E. / I.H.A.	JIS	UNI	EN	ISO	TRADE MARK
G-A9	-	-	-	-	-	-
G-A9Z1	-	-	-	-	-	-
AS4GU	-	-	-	45300	ALSi5Cu 1	-
A-S9U3	-	AC4B	-	46500	Al Si9 Cu3 (Fe) (Zn)	-
A-S5UZ	-	AC2A	-	45000	Al Si 6 Cu 4	-
A-S5U	-	AC2A	-	45400	Al Si 5 Cu 3	-
Cu/c1	-	C1020	-	CW008A	Cu-OF	-
Cu/a1	-	C1100	E-Cu57	CW004A	Cu-ETP	-
-	-	-	-	-	-	-
-	-	-	-	CW021A	-	-
Cu/b	-	C1220	-	CW024A	Cu-DHP	-
Cu/A3	-	-	-	CR006A	-	-
-	-	-	-	CW112C	CuNi3Si	-
-	-	-	-	-	Cu-AsP	-
-	-	-	-	-	-	-
-	-	-	-	-	-	-
-	-	-	-	-	CuCd1	-
-	-	-	-	CW105C	CuCr1	-
-	-	-	-	CW109C	CuNi1Si	-
-	-	-	-	CW111C	CuNi2Si	-
-	-	-	-	CW101C	CuBe2	-
-	-	-	-	CW102C	CuBe2Pb	-
-	-	-	-	CW110C	CuNi2Be	-
-	-	-	-	CW104C	CuCo2Be	-
-	-	-	-	CW120C	CuZr	-
-	-	-	-	CW115C	CuSi2Mn	-
-	-	-	-	CW116C	CuSi3Mn1	-
-	-	-	-	CW118C	CuTeP	-
-	-	-	-	CW114C	CuSP	-
-	-	-	-	CW113C	CuPb1P	-
-	-	C2100	-	CW500L	-	-
-	-	C2200	-	CW501L	-	-
-	-	C2300	-	CW502L	-	-
-	-	C2400	-	CW503L	-	-
-	-	-	CuZn28	-	-	-
-	-	C2600	-	CW505L	-	-
-	-	C2680	-	CW506L	-	-
-	-	-	-	-	-	-
-	-	C2700	-	CW508L	-	-
-	-	C2700	-	CW507L	-	-
-	-	C2800	-	CW509L	-	-
-	-	-	-	-	-	-
-	-	C3501	-	-	-	-
-	-	-	-	CW601N	-	-
-	-	C3501	-	CW600N	-	-
-	-	-	-	-	-	-
-	-	-	-	CW610N	-	-
-	-	C3601	-	CW603N	-	-
-	-	C3771	-	CW612N	-	-
-	-	C3603	-	CW614N	-	-
-	-	-	-	CW617N	-	-
-	-	-	-	-	-	-
-	-	-	-	-	-	-
-	-	-	-	-	-	-
-	-	-	-	-	-	-
-	-	-	-	-	-	-
-	-	-	-	-	-	-
-	-	-	-	-	-	-
-	-	-	-	CW723R	-	-
-	-	-	-	CW303G	-	-
-	-	-	-	CW307G	-	-
-	-	-	-	-	-	-
-	-	C5111	-	CW450K	-	-
-	-	C5102	-	CW451K	-	-
-	-	C5191	-	CW452K	-	-
-	-	C5212	-	CW453K	-	-
-	-	-	-	-	-	-
-	-	-	-	-	-	-
-	-	-	-	-	-	-
-	-	-	-	-	-	AMPCO 18
-	-	-	-	-	-	AMPCO 21
-	-	-	-	-	-	AMPCO 22

GROUPS / GRUPPI / GRUPE / GROUPES	AISI	W-stoff	DIN	BS	SS
<b>22</b> <30HRC NICKEL-BASE ALLOYS LEGHE DI NICKEL NICKELLEGIERUNGEN ALLIAGES DE NICKEL	N08800	1.4876	X10NiCrAlTi32-21	3075(NA15)	-
	N06075	2.4630	NiCr20Ti	HR5,203-4	-
	N07080	2.4631	NiCr20TiAl	HR401,601	-
	N06617	2.4663	-	-	-
	N06002	2.4665	NiCr22FeMo	HR6,204	-
	N06600	2.4816	-	-	-
	N06601	2.4851	NiCr23Fe	-	-
	N06625	2.4856	NiCr22Mo9Nb	-	-
	N08825	2.4858	NiCr21Mo	3072-76	-
<b>23</b> >30HRC NICKEL-BASE ALLOYS LEGHE DI NICKEL NICKELLEGIERUNGEN ALLIAGES DE NICKEL	N10665	2.4617	NiMo28	-	-
	N10002	-	NiCr17Mo17FeW	-	-
	N10003	-	-	-	-
	-	2.4642	-	-	-
	-	-	NiCo29Cr15MOAlTi	-	-
	N07718	2.4668	NiCr19Fe19NbMo	Hr8	-
	-	-	NiCr16FeTi	-	-
	N07725	-	-	-	-
	N07750	2.4669	NiCr 15 Fe 7 TiAl	HR505	-
N07751	2.4694	-	-	-	
<b>24</b> HARDOX 400, STAVAX, RAMAX	-	-	-	-	-
	-	1.2365	-	-	-
	-	-	-	-	-
<b>25</b> HARDOX 500	-	-	-	-	-
	-	-	-	-	-
<b>26</b> TITANIUM ALLOYS LEGHE DI TITANIO TITAN-LEGIERUNGEN ALLIAGES DE TITANE	-	3.7025	Ti 99,8	-	-
	-	3.7035	Ti 99,7a	-	-
	-	3.7055	Ti 99,6	-	-
	-	3.7065	Ti 99,5	-	-
	-	3.7115	TiAl5Sn2.5	TA14/17	-
	-	3.7164	TiAl6V4	TA10-13/TA29	-
	-	3.7175	TiAl6V6Sn2	-	-
-	3.7185	TiAl4Mo4Sn2	-	-	

AFNOR	U.N.E. / I.H.A.	JIS	UNI	EN	ISO	TRADE MARK
-	-	-	-	-	-	Incoloy 800
NC20T	-	-	-	-	-	Nimonic 75
NC20TA	-	-	-	-	-	Nimonic 80A
-	-	-	-	-	-	Inconel 617
NC22FeD	-	-	-	-	-	Hastelloy X
NC15Fe	-	-	-	-	-	Inconel 600
-	-	-	-	-	-	Inconel 601
NC22DNb	-	-	-	-	-	Inconel 625
NC21FeDU	-	-	-	-	-	Incoloy 825
-	-	-	-	-	-	Hastelloy B
NC17DWY	-	-	-	-	-	Hastelloy C
-	-	-	-	-	-	Hastelloy N
-	-	-	-	-	-	Inconel 690
NK27CADT	-	-	-	-	-	Inconel 700
Nc19FeNb	-	-	-	-	-	Inconel 718
Nc16FeTi	-	-	-	-	-	Inconel 722
-	-	-	-	-	-	Inconel 725
NC19FeNB	-	-	-	-	-	Inconel 750-X
-	-	-	-	-	-	Inconel 751
-	-	-	-	-	-	Hardox 400
-	-	-	-	-	-	Ramax
-	-	-	-	-	-	Stavax
-	-	-	-	-	-	Hardox 500
TA 1	-	-	-	-	-	-
TA 2-5	-	-	-	-	-	-
-	-	-	-	-	-	-
TA 6	-	-	-	-	-	-
-A6V	-	-	-	-	-	-
T-A5E	-	-	-	-	-	-
-	-	-	-	-	-	-
-	-	-	-	-	-	-

All the trademarks or tradenames mentioned belong to their respective owners.